

10. Brakes & Wheels

SECTION AT A GLANCE:

Disc Brake Conversion Kits	447
Baer Brake Kits	453
Wilwood Brakes	454
Dropped Spindles	458
Proportioning Valves.....	459
Power Brake Conversion	460
Brake Boosters	461
Master Cylinder	462
Vacuum Pump.....	465
Brake Rotors	466
Brake Drum	467
Brake Hoses.....	468
Brake Hardware	469
Parking Brake.....	470
Emergency Brake.....	471
E-Brake Kit	472
Brake Lines.....	474
Roller & Wheel Bearings.....	476
Wheels	477
Wheel Spinners	477
American Racing	479
Wheel Covers	480
Cragar Wheels	481
American Legend Wheels	482
Tires	484



STANDARD

UPGRADED



STOCK SPINDLE FRONT DISC BRAKE CONVERSION COMPONENTS O/S

Standard kit contains rotors, calipers, pads, seals, bearings and rubber hoses. The performance upgrades feature stainless brake hoses and cross-drilled and gas slotted rotors for use with our #797 brake kit stock spindles only. Will not clear '57 stock wheels. See page 476 for stock style wheels for disc brakes. Parts #2700 and #14262 use an 11-inch rotor.

1955-57 w/ Standard Rotors & Hoses (Shown).....	#2700.....	\$332.95/kit
1955-57 w/ Performance Rotors & Hoses.....	#14262.....	\$419.95/kit

2-INCH DROPPED SPINDLE FRONT DISC BRAKE CONVERSION KITS O/S

Standard kit includes rotors, calipers, pads, seals, bearings and rubber hoses. The Performance Upgrades feature stainless brake hoses and crossed-drilled and gas slotted rotors for use with our #2089 2-inch dropped spindles kits.

1955-57 w/ Standard Rotors & Hoses.....	#2703.....	\$309.95/kit
1955-57 w/ Performance Rotors & Hoses.....	#14263.....	\$391.95/kit

FRONT TO REAR BRAKE LINES FOR DISC BRAKE CONVERSIONS O/S

Front line from proportioning valve to caliper hose. Rear line from proportioning valve to rear end hose. For disc brake conversions. Complete set from proportioning valve to rear cylinders. Runs outside the frame.

1955-57 Steel.....	#10122.....	\$134.95/set
1955-57 Stainless.....	#10123.....	\$179.95/set



COMPLETE MIN-OFFSET FRONT DISC BRAKE CONVERSION KITS O/S

This all-in-one minimum offset front disc brake kit includes calipers, cross drilled and slotted rotors, an 8-inch dual booster/master/prop-valve assembly, stainless hoses, all necessary hardware, brackets and pre-bent lines. Dropped spindle kit is for CPP 2-inch dropped spindles. Will not clear stock 1957 14-inch wheels. See page 460 for an offset power brake booster bracket, part # 15272 for tall valve cover and OE power steering system applications.

1955-57 Stock Spindles	#15266	\$759.95/kit
1955-57 Dropped Spindles, Included	#15267	\$859.95/kit

MIN-OFFSET FRONT DISC BRAKE CONVERSION KITS FOR USE WITH STOCK SPINDLES O/S

Minimum offset kits for stock spindles move the wheels out 3/8-inch compared to 7/8-inch in other kits. Kits include; caliper brackets, calipers, rotors, bearings, seals, dust caps, hoses, and hardware for a hassle free installation. Works with 14-inch disc brake wheels. Does not include booster, master cylinder or pre-bent lines.

1955-57 w/ Performance Rotors & Hoses	#15254	\$548.95/kit
1955-57 w/ Standard Rotors & Hoses	#15255	\$448.95/kit



MIN-OFFSET FRONT DISC BRAKE CONVERSION KITS WITH DROPPED SPINDLES O/S

Minimum offset kits for drop spindles move the wheels in 3/16-inch from original. Kits include; dropped spindles, caliper brackets, calipers, rotors, bearings, seals, dust caps, hoses, and hardware for a hassle free installation. Will not clear stock '57 14-inch wheels.

1955-57 w/ Performance Rotors & Hoses	#15256	\$598.95/kit
1955-57 w/ Standard Rotors & Hoses	#15257	\$498.95/kit

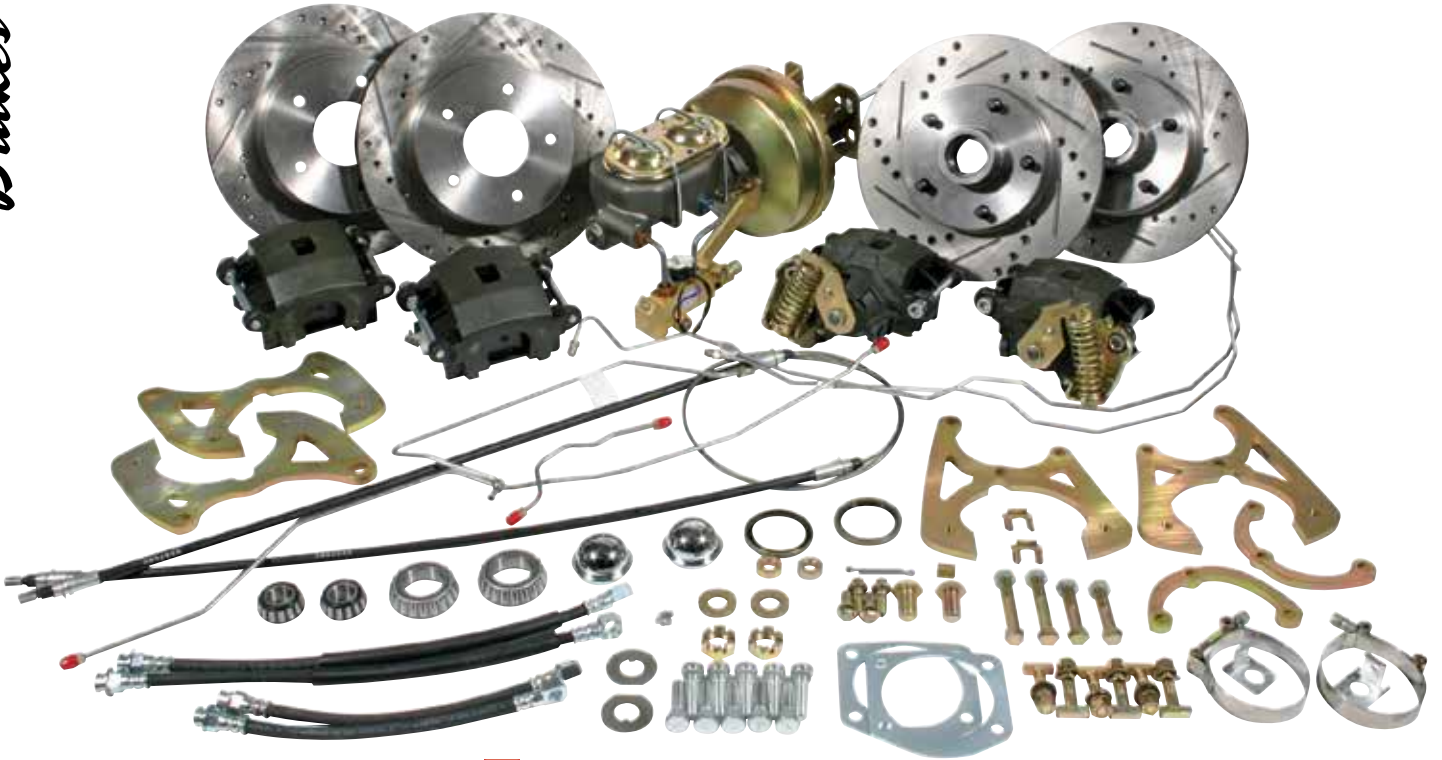

4-WHEEL DISC BRAKE CONVERSION KITS O/S

You've been asking for a single part number, all in one, 4-wheel disc brake kit and here they are. These kits use the minimum offset front disc brake kit and stock rear end rear disc brake kit. You get calipers, cross drilled and slotted rotors, an 8-inch dual booster/master/prop-valve assembly, all necessary hardware, brackets, cables, front hoses and pre-bent brake lines. You will need to purchase a front to rear frame brake line and rear flex hose or reuse your existing parts. Will not clear stock 1957 14-inch wheels. For part #15264, see page 460 for an offset power brake booster bracket, part # 15272 for tall valve cover and OE power steering system applications.

1955-57 Stock Spindles	#15264.....	\$1519.95/kit
1955-57 w/ Dropped Spindles	#15265.....	\$1449.95/kit
1955-57 w/ Dropped Spindles, Chrome Booster	#16494.....	\$1749.95/kit
1955-57 Stock Spindles, Chrome Booster.....	#16495.....	\$1649.95/kit



FRONT DISC BRAKE CONVERSION KIT BRACKETS MADE IN THE USA

This simple kit bolts on to your existing stock spindles. Each kit contains adapting brackets, hardware and instructions that will inform you which parts are necessary for your application. We carry the rotors, calipers, master cylinder, power booster, and proportioning valve. This kit is extremely well engineered. We wouldn't short-sell your safety! (**Note:** Check your tire clearance before installation. This kit will increase the width of your car by as much as 7/8-inch per side.) **Made in the USA.**

1955-57	#797.....	\$129.95/kit
---------------	-----------	--------------



BIG BRAKE DISC CONVERSION KITS O/S

Big Brake Kits use a 13-inch rotor up front and a 12-inch on the rear. They feature red powder coated calipers, braided steel hoses, aluminum hubs, Zinc washed cross drilled and slotted rotors, rear cables and all the needed brackets and hardware to get the job done right. Part #15263 includes a dropped spindle. When installing the front and rear kit, #15262, you will need to purchase a front to rear frame line and rear flexible hose or reuse your existing parts. 17-inch or larger wheel is required for clearance.

1955-57 Front, Stock Spindles, 13"	#15260.....	\$899.95/kit
1955-57 Rear, Stock Rear End, 12"	#15261.....	\$799.95/kit
1955-57 Front & Rear, Stock Spindles & Rear End	#15262.....	\$1650.95/kit
1955-57 Front w/ Dropped Spindle, 13"	#15263.....	\$995.95/kit
1955-57 Rear w/ Ford 9" Rear End, 3/8" Flange Stud, 12"	#16358.....	\$699.95/kit
1955-57 Rear w/ Ford 9" Rear End, 1/2" Flange Stud, 12"	#16359.....	\$699.95/kit
1955-57 Rear w/ 10/12 Bolt Rear Ends, 12"	#16944.....	\$749.95/kit





REAR END DISC BRAKE KITS O/S

Get the ultimate in braking power by converting to four wheel disc brakes with a rear disc brake conversion kit. More consistent stopping and less fade than the original drum brakes. For stock and 10/12 bolt rear ends only. Easy bolt-on installation. Kit includes 11-inch rotors, calipers with built-in E-brake, rubber hose kit and all mounting hardware. Upgraded versions come with braided stainless hoses and cross-drilled and gas slotted rotors. Not for use with factory style 14 or 15-inch steel wheels.

1955-64 Stock Rear End, w/ Standard Rotors & Hoses	#2701A.....	\$784.95/kit
1955-64 Stock Rear End, w/ Performance Upgraded Rotors & Hoses.....	#14264.....	\$784.95/kit
1955-57 10/12 Bolt Rear End w/ Standard Rotors & Hoses	#16945.....	\$599.95/kit
1955-57 10/12 Bolt Rear End w/ Performance Rotors & Hoses	#16943.....	\$729.95/kit

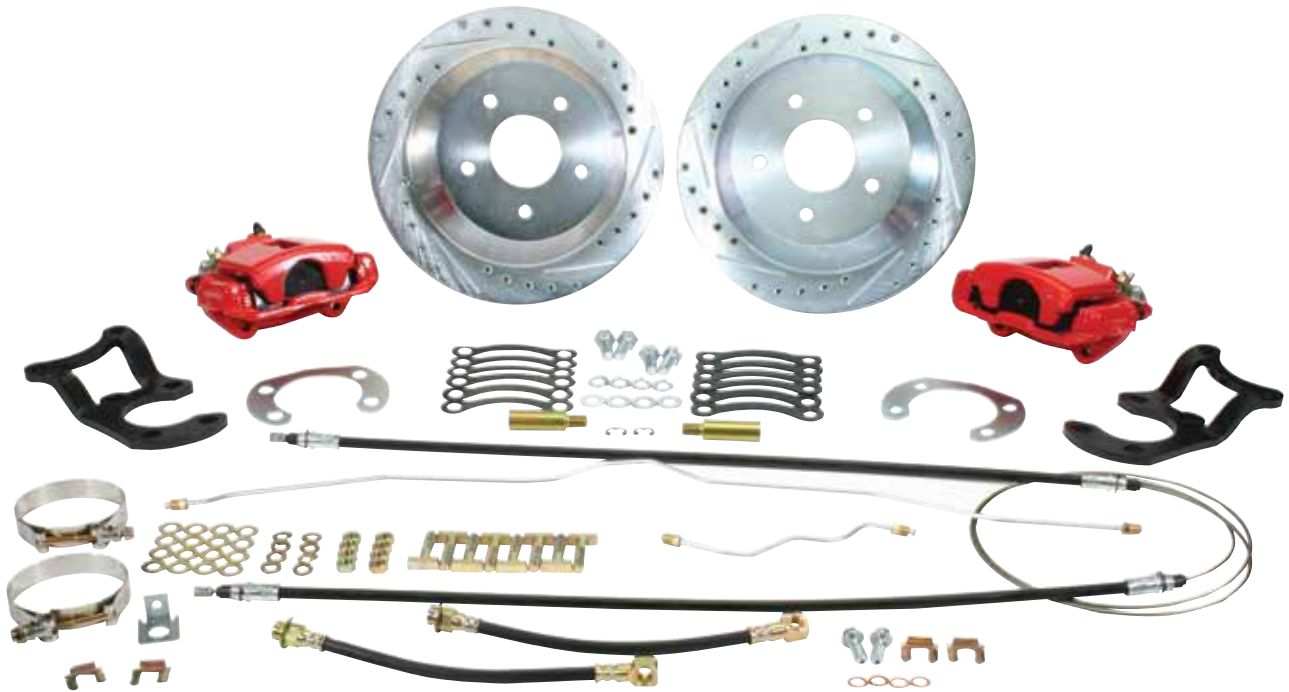

REAR DISC BRAKE KITS FOR FORD 9-INCH REAR END O/S

If you have installed a Ford 9-inch rear end in your classic and want to have rear disc brakes, this is the kit for you. This complete kit will work for both small and large bearing Ford 9-inch rears and comes with everything you need to install it on your classic. Part #16240 includes standard 11-inch brake rotors, calipers and rubber hoses, while part #16241 includes 11-inch performance drilled/slotted brake rotors, calipers and braided stainless steel hoses.

1955-57 w/ Standard Rotors & Hoses	#16240.....	\$599.95/kit
1955-57 w/ Performance Rotors & Hoses	#16241.....	\$738.95/kit



BAER SS4 REAR DISC BRAKE KITS O/S

The SS4 Rear system was designed to go along with their Track4 front offering. This features a 12-inch 1-piece rotor with a drum in hat park brake with a full billet backing plate.

1955-57 12"..... #17287..... **\$1295.95/kit**

The SS4+ 13-inch rear is a great option for those looking at the Pro+ front, or Extreme+ front that doesn't need or want that big of a brake on the rear. The SS4+ 13-inch features a 13-inch 2-piece rotor with a drum in hat park brake.

1955-57 13"..... #17288..... **\$1395.95/kit**

BAER BRAKE SS4+ FRONT OE SPINDLE DISC BRAKE KIT O/S

The SS4+ front system features all the benefits of their larger brake systems just in a smaller package to fit 15-inch wheels. This is a perfect system for those looking to retain a factory type 15-inch wheel, or the enthusiast that wants to have a larger brake with the option to go back to that stock look.

1955-57 11"..... #17281.... **\$1095.95/kit**



BAER BRAKE PRO+ FRONT OE SPINDLE DISC BRAKE KIT O/S

The Pro+ will allow you to upgrade to a 2-piece rotor (a popular upgrade due to cosmetics and weight savings) and give you 6 piston calipers. This is the first system they offer that will allow you to have the exact same looking brake front and rear! (Note: Baer is the only company to offer this). The SS4+ rear option is a cost effective, cosmetically matching rear option as well!

1955-57 13"..... #17283.... **\$2445.95/kit**



BAER BRAKE TRACK4 FRONT OE SPINDLE DISC BRAKE KIT O/S

The Track4 is Baer's most popular front offering. The Track4 is available with 13-inch 1-piece rotors and is a great brake upgrade for those looking to fill your 17-inch wheels, update your car to a modern brake and have a great visual impact! Comes complete with everything needed to mount to the corners on the car. Looking for a matching rear kit? Check out the SS4 as a matching rear option with park brake. See parts #17287-#17288, shown above.

1955-57 13"..... #17282.... **\$1795.95/kit**



BAER SS4+ FRONT DISC BRAKE KIT FOR HEIDT'S SPINDLES O/S

1955-57 11"..... #17284.... **\$1295.95/kit**

BAER TRACK4 FRONT DISC BRAKE KIT FOR HEIDT'S SPINDLES O/S

1955-57 13"..... #17285.... **\$1795.95/kit**

BAER PRO+ FRONT DISC BRAKE KIT FOR HEIDT'S SPINDLES O/S

1955-57 13"..... #17286.... **\$2445.95/kit**

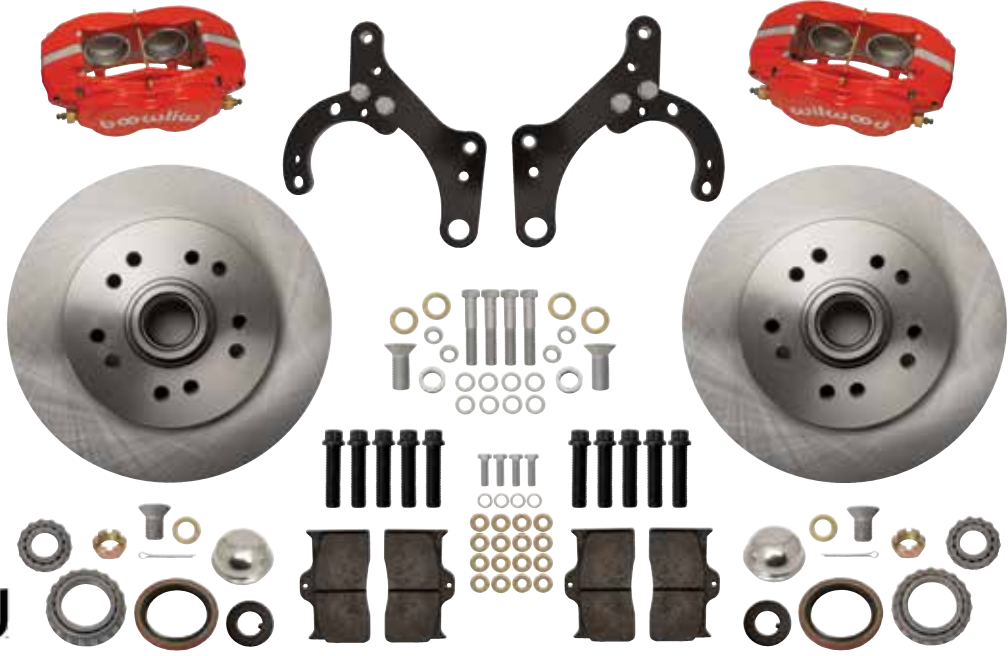

WILWOOD BRAKE KITS



WILWOOD CLASSIC SERIES FRONT BRAKE KIT O/S

Wilwood's Classic Series front disc brake kits offer disc brake upgrade solutions for many OEM drum or disc spindles. These kits feature the FDL-M four piston forged aluminum calipers and 11.5-inch diameter one-piece rotors provide superb dimensional stability and wear resistance. These versatile kits can be used with either manual or power boost master cylinders, and come complete with calipers, rotors, brackets, hardware and detailed installation instructions.

- 1955-57 OE Spindles, Black Calipers, 11.5" #19295..... \$599.95/kit
- 1955-57 OE Spindles, Red Caliper, 11.5" (Shown) #19296..... \$599.95/kit
- 1955-57 CPP Drop Spindles, Red Calipers, 11.5" #19297..... \$599.95/kit
- 1955-57 CPP Drop Spindles, Black Calipers, 11.5"..... #19363..... \$599.95/kit

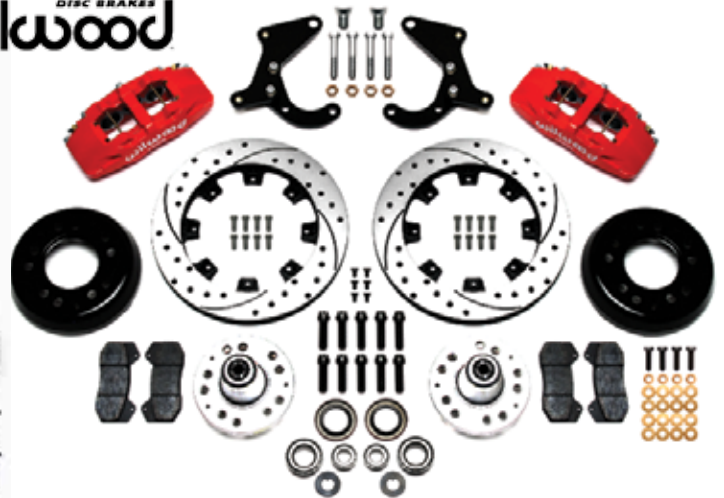

WILWOOD FNSL6R FRONT DISC BRAKE KIT O/S

Wilwood's FNSL6R billet Forged six-piston calipers with 13-inch rotors deliver the ultimate combination for braking power and style for traditional non-ABS spindles on American muscle cars. Requires 17-inch and larger wheels.
All Drop Spindles #18537... \$1699.95/ea.

WILWOOD DYNA PRO 6 FRONT DISC BRAKE KIT O/S

Wilwood's DynaPro 6 six piston forged billet calipers combined with 12.19-inch diameter rotors offer an enhanced brake capacity and pad performance alternative to the bigger six piston kits.

All 12.19" , W-DP6P, Red..... #18538... \$1229.95/ea.



WILWOOD FDL PRO-SERIES FRONT DISC BRAKE KITS O/S

Wilwood's FDL Pro-Series front hub kits offer complete disc brake upgrade solutions for traditional non-ABS applications. Based on the forged billet Dynalite caliper, these versatile kits work for a daily driver, serious competition, or show enthusiast. The kits provide plenty of clearance inside popular 15-inch wheels and can be used with either manual or power boost master cylinders. **11-inch rotors.**

- All Drilled w/ Red Calipers..... #18569..... \$908.95/kit**
- All Plain w/ Black Calipers..... #18570..... \$802.95/kit**
- All Heidt's Dropped Spindles, Drilled, Red**
..... #18565..... \$929.95/kit
- All Dropped Spindle, Plain, Black**
..... #18566..... \$914.95/kit

WILWOOD FDL BIG BRAKE FRONT DISC BRAKE KITS O/S

Wilwood's FDL Big Brake front hub kits provide larger diameter brake rotors for traditional non-ABS spindles. Forged billet Dynalite calipers, 12.19-inch diameter rotors, and high performance Wilwood brake pads for big brake stopping power. **12.19-inch rotors.**

- All Drilled w/ Polished Caliper..... #18562.... \$1105.95/kit**
- All Heidt's Dropped Spindles, Drilled, Red**
..... #18563..... \$979.95/kit
- All Dropped Spindle, Plain, Black . #18564..... \$864.95/kit**
- All Drilled w/ Red Caliper..... #18567.... \$1079.95/kit**
- All Plain w/ Black Caliper..... #18568..... \$977.95/kit**
- All Plain, w/ Polished Caliper..... #19475..... \$879.95/kit**
- All Drilled, w/ Polished Caliper..... #19488..... \$979.95/kit**



WILWOOD FDL PRO-SERIES REAR DISC BRAKE KITS O/S

Wilwood's FDL Pro-Series rear disc kits provide a complete solution for rear axles that require a parking brake. Forged billet Dynalite four piston calipers, 12.19-inch one-piece drum/rotors and high friction pads provide optimized and balanced braking. A neatly hidden internal shoe system provides a clean installation with superior static holding power for parking. **12.19-inch rotors.**

- All Drilled w/ Red Caliper..... #18558..... \$895.95/kit**
- All Plain w/ Black Caliper..... #18559..... \$789.95/kit**

WILWOOD DYNAPRO PRO-SERIES REAR DISC BRAKE KITS O/S

Wilwood's Dynapro Low-Profile Pro-Series rear disc brake kits provide a complete solution for applications that require a parking brake assembly and extra clearance for 14-inch or 15-inch wheels. Forged billet Dynapro Low-Profile four-piston calipers with 11-inch one-piece hat and rotor assemblies and high friction pads provide optimized and balanced braking. **11-inch rotors.**

- All Drilled w/ Red Caliper..... #18560..... \$895.95/kit**
- All Plain w/ Black Caliper..... #18561..... \$789.95/kit**



DISC BRAKES
wilwood

WILWOOD MASTER CYLINDERS

Wilwood's tandem aluminum master cylinders feature fluid ports on both sides of the bore and the slotted flange mounting means it will fit most domestic cars and trucks from the mid 1960's to present. Stroke is set at 1.1-inch with a volume ratio of 2:1 between the primary and secondary chambers. Machined from high-pressure die castings, each master cylinder weighs 3 pounds.

- All 1-1/8" Bore, Polished #18550..... \$239.95/ea.
- All 1" Bore, Polished #18551 \$239.95/ea.
- All 7/8" Bore, Polished #18552..... \$239.95/ea.
- All 1-1/8" Bore, Black #18553..... \$239.95/ea.
- All 1" Bore, Black..... #18554..... \$239.95/ea.
- All 7/8" Bore, Black..... #18555..... \$239.95/ea.



WILWOOD MASTER CYLINDER KITS WITH COMBO VALVE

Wilwood has packaged their popular aluminum tandem chamber master cylinder with their combination proportioning valve, mounting bracket, fluid tubes and mounting hardware in a kit. The slotted flange mounting makes the master cylinder a simple bolt on, compatible with manual or power brake system applications. The Wilwood combination proportioning valve substantially simplifies wiring and brake proportioning adjustments on vehicles with custom brake systems. The combination block maintains full isolation between front and rear fluid circuits and is specifically designed to accompany the master cylinder. The combo valve and bracket are black E-coated for a performance look and the stainless steel fluid tubes are precision bent with pre-installed stainless tube nuts.

- All 1-1/8" Bore, Polished #18544..... \$359.95/kit
- All 1" Bore, Polished #18545..... \$359.95/kit
- All 7/8" Bore, Polished #18546..... \$359.95/kit
- All 1-1/8" Bore, Black #18547 \$359.95/kit
- All 1" Bore, Black..... #18548..... \$359.95/kit
- All 7/8" Bore, Black..... #18549..... \$359.95/kit



DISC BRAKES
wilwood

WILWOOD RESIDUAL PRESSURE VALVES

Wilwood's two pound and ten pound residual pressure valves retain a minimum brake line pressure to help eliminate excessive pedal travel in both disc and drum brake systems. The two pound valve is used in disc brake applications where the master cylinder is mounted below the horizontal plane of the calipers and fluid drain back occurs from gravity and vibration, thereby causing excessive caliper piston retraction and a longer brake pedal stroke. The minimal two pound residual pressure prevents fluid from flowing back without causing the brakes to drag. With drum brakes, a ten pound valve is used to compensate for return spring tension and maintain wheel cylinder sealing in the drums.

- All 10-lb..... #18539..... \$19.95/ea.
- All 2-lb..... #18540..... \$19.95/ea.

WILWOOD UNIVERSAL MASTER CYLINDER PUSHROD KIT

Wilwood's universal brake pedal pushrod kit allows many common configurations for custom installation of power boosters or manual master cylinders. Adjustable length kit contains all the necessary components for pedal engagement and height adjustment for most common types of installations. Kit includes: adjustable length pushrods, unions, clevis, eyelet and retainer.

- All..... #18541 \$59.95/ea.





WILWOOD PROPORTIONING VALVE COMBO

With their new proportioning / combo valve and bracket kit Wilwood has created an elegant way to mount the master cylinder and prop / combo valve as a unit. This kit is specifically designed to work in conjunction with Wilwood aluminum tandem master cylinders in manual or boosted system applications. Kit includes: stainless steel fluid tubes precision bent with preinstalled stainless tube nuts for a simple bolt-on installation between the combination proportioning valve and the Wilwood tandem master cylinder, mounting hardware, bracket and prop/combo valve.

All w/ Mount Bracket, Left Hand... #18542.....\$119.95/kit

WILWOOD PROPORTIONING VALVE COMBO

Wilwood's new combination proportioning valve substantially simplifies mounting, plumbing, wiring and brake proportioning adjustments on vehicles with custom brake systems. The combination block maintains full isolation between front and rear fluid circuits and can be used in conjunction with any tandem outlet or dual mount master cylinder assemblies. The rear circuit has a single inlet and single outlet with the adjustable proportioning valve. The front circuit has a single inlet with two outlets. It can be run as a single outlet with one outlet plugged, or used to split the plumbing on its way to the front calipers.

All Black #18543.....\$89.95/kit



WILWOOD STAINLESS DISC BRAKE HOSES

Wilwood's rear disc conversion stainless steel braided flexline kits are manufactured to high quality standards and include all the required fittings. The two hoses are 12-inch long and come with two 90° 1/8-inch -27 NPT fittings, two straight -3 to 3/8-24 IF chassis fittings and two line clips.

All Rear..... #18556.....\$83.95/pr.

Wilwood highly recommends using these top quality flexlines as replacement for the OE rubber hoses when doing your front disc brake conversion upgrade. The two hoses are 16-inch long and come with two 90° 1/8-inch -27 NPT fittings, two straight -3 to 3/8-24 IF chassis fittings and two line clips.

All Front (Not Shown)..... #18557.....\$71.95/pr.

WILWOOD BRAKE FLUID

Wilwood EXP Super Hi-Temp 600 Plus DOT 4 Racing Brake Fluid has been specially formulated for racing applications where brake systems consistently operate at very high temperatures. In addition to guarding against vapor lock, EXP Super Hi-Temp 600 Plus Racing Brake Fluid maintains its viscosity and lubricity under extreme temperatures for maintaining brake system reliability and performance.

All EXP6000 Plus DOT 4, 16.5 oz.

..... #18535.....\$19.95/ea.



WILWOOD

WILWOOD RACING BRAKE FLUID

Wilwood's specially formulated Hi-Temp° 570 DOT 3 Racing Brake Fluid has a minimum 570° F. dry boiling point to withstand the severe heat requirements of automotive racing. Hi-Temp° 570's low viscosity allows easy bleeding of your brake system, eliminating aeration of the brake fluid caused by foaming due to excessive pumping of the pedal.

All 570 DOT 3, 12 oz. #18536.....\$10.95/ea.



SPINDLES

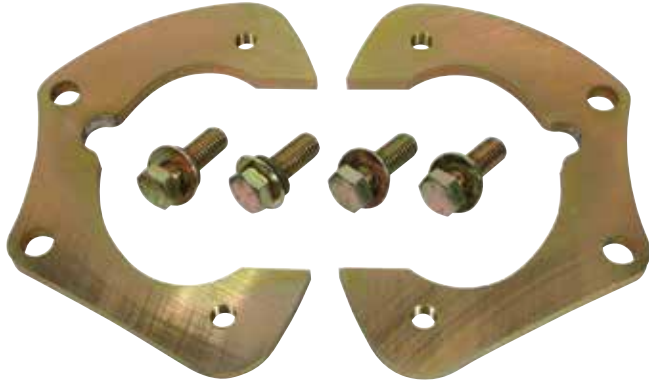

CLASSIC PERFORMANCE MODULAR 2-INCH DROPPED SPINDLES

Modular drop spindles offer you the flexibility to install either 11-inch rotors or go "BIG" with a 13-inch disc brake conversion kit. There is no loss of turning radius and they accept stock and Unisteer steering arms. When used with 11-inch rotors the wheels are moved in 3/16-inch, with the 13-inch rotors they are moved out 1/2-inch. Works with 15-inch or larger disc brake wheels. Will not interchange with stock height disc components.



- 1955-57 w/ Small Metric Caliper Brackets #15259.....\$299.95/pr.
- 1955-57 w/ Large Caliper Brackets #15259A.....\$299.95/pr.

FRONT BRAKE CALIPERS WITH DISC CONVERSION STOCK OR DROPPED SPINDLES

This replacement loaded metric caliper can be mounted on either side and features a larger piston for more stopping force.



- 1955-57 #12411 \$65.95/ea.

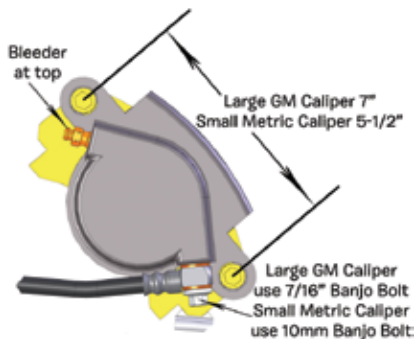

HEIDT'S 2-INCH STEEL DROPPED SPINDLES

Use part #2089 with dropped spindles brake components, part #2703 shown on page 448. Can accept large or small GM calipers. Contact Wilwood for Wilwood brackets.

- 1955-57 w/ Small Caliper Metric Brackets #2089.....\$449.95/pr.
- 1955-57 w/ Large Caliper Brackets #2089A.....\$459.95/pr.



STOCK HEIGHT SPINDLES

- 1955-57 1-Piece Forged, Drum/Disc #16977.....\$159.95/pr.



STOCK SPINDLE BRAKE ROTOR

- For stock spindle disc conversions.
1955-57 #12410..... \$51.95/ea.



STOCK SPINDLE BOLTS

- 1955-57 #2696..... \$13.95/set



#2521

#2521A

PROPORTIONING VALVES

All Adjustable #2521 \$49.95/ea.
 All 2/4 Disc Brakes #2521A \$49.95/ea.

ADJUSTABLE PROPORTIONING VALVE AND DISTRIBUTION BLOCK KITS

Proportioning valve and brake light switch all-in-one. It's designed for dual reservoir master cylinders and has two inlets, two outlets for front brakes and one outlet for the rear brakes. Kits include five stainless 3/16-inch fittings, brake light switch and wiring pigtail.



All Black #15060 \$99.95/kit
 All Polished #15061 \$115.95/kit



ADJUSTABLE PROPORTIONING VALVE

All Chrome #17574 \$59.95/pr.



CHROME BRAKE PROPORTIONING VALVE KITS

1955-57 2/4 Disc Brakes #17152 \$109.95/kit



PROPORTIONING VALVE BRACKET

For use with 605 box. Will not work with stock box. Some modifications to brake lines are necessary.

1955-57 #12186 \$28.95/ea.

COMBINATION/PROPORTIONING VALVE TOOL

For brake systems utilizing preset proportioning valves (2521A/B). Use this tool when bleeding your brakes to lock the valve in place and keep it from tripping, making it difficult to properly bleed the brake system. Installs in place of the warning light switch. Replace warning light switch when bleeding is complete.



All #16941 \$11.95/pr.



PROPORTIONING VALVE BRACKET AND LINE KITS

1955-57 Chrome #17155 \$49.95/kit
 1955-57 #11205 \$16.95/kit

HYDRAULIC ASSIST POWER BRAKE CONVERSION KITS

Hydraulic assist braking systems use the power steering pump to power the hydro-boost, which means you have no problems with low vacuum like you have with traditional vacuum assist power brake systems. By going with a hydraulic assist system, which is not dependent on engine speed or engine vacuum, you don't need to mess with vacuum cans, pumps or electronic gadgets which only offer a temporary solution to low vacuum problems. Hydraulic assist systems provide substantial gains in overall braking power and the fastest braking response



time of any power brake system available. Danchuk offers 2 levels of kits to fit your particular application. Level 3 kits are ideal for floor shift cars, as they tend to interfere with stock column shift linkages. Level 4 kits give you maximum engine and column clearance and are ideal for column shift cars and tall block big block cars. Your car must have power steering to use a hydraulic assist system and these systems are designed to be used with master cylinders with a shallow bore piston. Recommended for cars with at least front disc brakes.

1955-57 w/ Lines, Level 3 (Shown)	#13983	\$699.95/kit
1955-57 w/o Lines, Level 3	#13984	\$449.95/kit
1955-57 w/ Lines, Level 4	#13985*	\$749.95/kit
1955-57 w/o Lines, Level 4	#13986*	\$524.95/kit

* **Note: Level 4 kits are recommended if car is using factory column shifter.**

RESIDUAL PRESSURE CHECK VALVES

When upgrading your stock drum brake system to disc brakes a proportioning valve is needed to ensure proper amount of pressure going to the front and rear wheels. A residual check valve is sometimes needed when using an adjustable prop valve.

All 2-lbs., Blue	#17570	\$13.95/pr.
All 2-lbs., Chrome	#17571	\$19.95/pr.
All 10-lbs., Red	#17572	\$13.95/pr.
All 10-lbs., Chrome	#17573	\$21.95/pr.

OFFSET POWER BRAKE BOOSTER BRACKET

This bracket moves the booster 2-inch to the left and 1-3/4-inch up for additional clearance.

1955-57#15272.\$149.95/ea.



CHROME POWER BRAKE BOOSTER KITS

These are our most popular power disc brake conversion kits in chrome. They feature a chromed master, cap, bracket, prop valve and stainless lines.

1955-57 2/4 Disc Brakes, 8", Dual Diaphragm	#14322	\$599.95/kit
1955-57 2/4 Disc Brakes, 7" Dual Diaphragm	#15271	\$583.95/kit

#14975

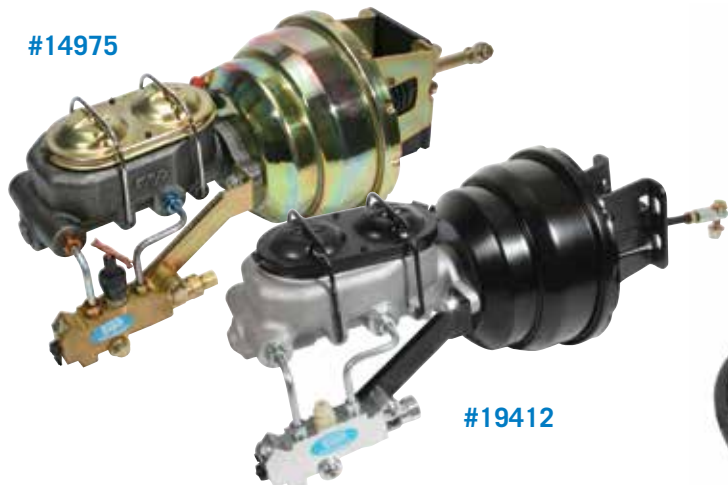

#19412

POWER BRAKE BOOSTER KITS

Update your braking system with these power brake units which provide improved braking power with minimal pedal effort. Installation is simple; just bolt the unit to the firewall and drill a new hole in the pedal arm to attach the pushrod. Dual reservoir brake systems provide an extra measure of safety, but require additional lines. Power boosters require a minimum of 17-inch of vacuum. If your engine produces less, we suggest you check out our HydroBoost systems. Power boosters will not clear factory power steering pumps/generators. For proper brake pedal effort, we recommends at least an 8-inch booster on Disc/Drum or Disc/Disc brake systems. 9-inch booster will not clear big blocks and may interfere with some small block tall valve covers. Please check clearance before ordering.

- 1955-57 Drum/Drum, 9" Single Diaphragm**
- Single Reservoir #2095..... \$299.95/kit
- 1955-57 Drum/Drum, 8" Single Diaphragm**
- #18660..... \$299.95/ea.
- 1955-57 Drum/Drum, 8" Single Diaphragm, Offset**
- #18661..... \$349.95/ea.
- 1955-57 Drum/Drum, 7" Single Diaphragm,**
- Single Reservoir #2095A..... \$299.95/kit
- 1955-57 Drum/Drum, 7" Single Diaphragm,**
- Dual Reservoir #2096A..... \$299.95/kit
- 1955-57 2/4 Disc Brakes, 7" Single Diaphragm**
- #2098A..... \$299.95/kit
- 1955-57 2/4 Disc Brakes, 7" Dual Diaphragm**
- #15269..... \$299.95/kit
- 1955-57 2/4 Disc Brakes, 8" Dual Diaphragm**
- #12157..... \$349.95/kit

OFFSET POWER BRAKE BOOSTER KIT

Same style as above but with an offset bracket that moves booster 2-inch to the left and 1.75-inch up for additional clearance. 8-inch dual diaphragm with proportioning valve.

- 1955-57 2/4 Disc Brakes..... #14976..... \$375.95/kit**

MIDNITE SERIES POWER BRAKE BOOSTER KIT

- 1955-57 Disc/Drum, Disc/Disc, 8" Dual Diaphragm,**
- Combo Valve #19412..... \$299.95/kit**



HYDRAULIC BRAKE BOOSTER KITS

The "Show Stopper" package includes hydraulic brake assist unit with aluminum firewall mounting bracket. Master cylinder, prop and stop block kit, chrome accumulator cover, stainless pressure hoses, rubber return hoses and all necessary hardware for installation.

- 1955-64 Show Stopper #17978..... \$978.95/ea.**

The "Street Beast" package includes hydraulic brake assist unit with steel firewall mounting bracket, aluminum Corvette style master cylinder, side mounted prop and stop block kit, rubber pressure and return hoses and all necessary hardware for installation.

- 1955-64 Street Beast #17979..... \$749.95/ea.**

POWER BRAKE BOOSTERS WITH BRACKETS

For those building their own brake kit or want to update to power brakes, these boosters come with the proper bracket and pedal rod, as well as long and short master cylinder pushrods to work with both shallow and deep bore master cylinders.

- 1955-57 8" Dual #16644..... \$199.95/ea.**
- 1955-57 8" Dual, Chrome #16645..... \$279.95/ea.**

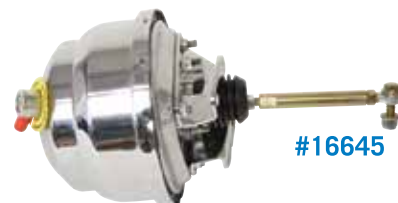

#16645

TCI ROLL STOP KIT

TCI's Roll Stop allows you to do a burnout like the professionals. Simply pump the brake pedal, apply the roll stop and release the brake pedal. The roll stop keeps the front brakes applied. Kit includes the solenoid, microswitch, mounting bracket, fuse connector and mounting hardware. Brake line modification required.

- All..... #13046..... \$114.95/kit**





MASTER CYLINDERS WITH BUILT-IN ADJUSTABLE PROPORTIONING VALVES

Featuring a double adjustable proportioning valve, removable metering valve, stop light control, larger fluid capacity, and smaller size, this unit solves the problems associated with trying to plumb together four or five separate pieces. This is a master cylinder, proportioning valve, metering valve and stop light all in one package. Each contains two circuits, a front and rear. The front circuit contains the metering valve which is required on cars that have disc brakes on the front wheels and drum brakes on the rear wheels. The rear contains the adjustable proportioning valve and the maximum rear pressure adjustment. The adjustable proportioning valve controls the balance of pressure between the front and rear brakes.

- All Chrome, 1" Bore #13200..... \$189.95/ea.
- All Chrome, 1-1/8" Bore..... #15370..... \$199.95/ea.



ALUMINUM/CHROME MASTER CYLINDER ASSEMBLIES

These cast aluminum/chrome plated master cylinders are an easy upgrade to any power or manual disc brake conversion and includes chrome plated valve and bracket.

- All Disc/Drum, 1" Bore #15371 \$265.95/ea.
- All Disc/Disc, 1" Bore #15372 \$265.95/ea.
- All 2/4 Disc Brakes, 1-1/8-in Bore #15374..... \$265.95/ea.



ALUMINUM BRAKE MASTER CYLINDERS, CHROME PLATED

Works with 2 or 4-wheel disc brake applications, power or non-power.

- All 1" Bore #14977 \$139.95/ea.
- All 1-1/8" Bore #14978 \$148.95/ea.

BRAKE MASTER CYLINDER ASSEMBLY

This unit is factory fresh, not just another rebuild! For standard brakes. Some brake line modification necessary.



- 1955-57 #023 \$81.95/set

DRUM BRAKE DUAL RESERVOIR MASTER CYLINDER

This dual reservoir drum/drum master cylinder allows you to add safety by splitting the the brake system front to rear. Works with manual brakes or with boosters with a long push rod pin. Mounts to firewall using only two of the original four mounting studs. You must supply additional brake lines.



- 1955-57 #16360..... \$69.95/ea.



SMOOTH MASTER CYLINDERS

CPP's new smooth aluminum master cylinders feature a beautiful black or chrome finish with two ports, 1/2-20 in front and 9/16-18 in the rear.

- All Black, Disc, 1" Bore #18684..... \$94.95/ea.
- All Black, Disc, 1-1/8" Bore #18685..... \$94.95/ea.
- All Chrome, Disc, 1" Bore #18686..... \$115.95/ea.
- All Chrome, Disc, 1-1/8" Bore #18687 \$115.95/ea.



#18172 & #18174

#18171 & #18173

BAER REMASTER MASTER CYLINDERS

The Baer Remaster is a fully machined, billet aluminum master cylinder that features:

- Fully Machined out of aluminum in Phoenix, Arizona.
- Comes standard in Anodized Gray, Black, and Polished.
- Compact short design allows this master to fit in a wide variety of applications.
- Includes a bullet (insert adapter) for long pushrod applications.
- Machined screw-in caps for easy access to fill. Knurled caps to make removal easy.
- Bolt on Firewall mount bracket.
- Laser etched logos and part numbers for a finished look on anodized version.
- Bolt on proportioning valve block (See pn#'s 18175-76) is available separately.
- Available in 1-inch and 1-1/8-inch bores, 15/16-inch available by special order.

All 1" Bore, Gray	#18171	\$399.95/ea.
All 1" Bore, Polished	#18172	\$474.95/ea.
All 1" Bore, Black	#18177	\$399.95/ea.
All 1-1/8" Bore, Gray	#18173	\$399.95/ea.
All 1-1/8" Bore, Polished	#18174	\$474.95/ea.
All 1-1/8" Bore, Black	#18178	\$399.95/ea.



BAER REMASTER PROPORTIONING VALVES WITH MOUNTS

All Baer Remasters have the ability to bolt a proportioning valve block to the bottom of the master cylinder. These kits include the valve, block and mounting hardware.

All Gray	#18175	\$74.95/pr.
All Polished	#18176	\$84.95/pr.
All Black	#18513	\$74.95/pr.



#19468

COMPACT MASTER CYLINDERS

Wilwood's Compact Tandem Master Cylinders are designed for manual (7/8-inch, 15/16-inch, 1-inch) or power (1-inch, 1-1/8-inch) applications depending on bore size, 7/8-inch and 15/16-inch come with a pushrod, 1-inch and 1-1/8-inch do not. They are designed for mount flanges from 3.22-inch to 3.40-inch, common measurements for most domestic cars and trucks from the mid-1960's to present, and offer fluid outlet ports on both sides of the bore.

All 7/8" w/ Pushrod, Black.....	#19467	\$277.95/ea.
All 7/8" w/ Pushrod, Polished	#19468	\$277.95/ea.
All 15/16" w/ Pushrod, Black.....	#19469	\$277.95/ea.
All 15/16" w/ Pushrod, Polished ..	#19470	\$277.95/ea.
All 1" w/o Pushrod, Black.....	#19471	\$277.95/ea.
All 1" w/o Pushrod, Polished	#19472	\$277.95/ea.
All 1" w/o Pushrod, Black.....	#19473	\$277.95/ea.
All 1" w/o Pushrod, Polished	#19474	\$277.95/ea.

DISC BRAKE MASTER CYLINDERS

For 2 or 4-wheel disc brake conversions only. Be sure to order the correct proportioning valve (#2521A or #2521B) for your application.



Includes piston bore depth adapter, will work with both power and non-power brake systems.

All 1" Bore	#10252	\$39.95/ea.
All 1-1/8" Bore	#18363	\$59.95/ea.

CHROME ALUMINUM DISC BRAKE MASTER CYLINDERS

All 1" Bore	#17149	\$79.95/ea.
All 1-1/8" Bore	#17150	\$85.95/ea.





#2522

MASTER CYLINDER COVER



Another chrome favorite for the custom engine compartment! For stock master cylinders. **Made in the USA.**

1955-57 Plain..... #2522..... \$108.95/ea.



FRAME MOUNT BRAKE PEDAL/MASTER CYLINDER BRACKET

Clean up your firewall with this frame mounted pedal and booster/master cylinder bracket. This kit bolts under the floor, but is tucked up high so it won't cause ground clearance problems. Kit includes: brake pedal assembly and frame bracket. 7-inch booster/master/prop valve sold separately.

1955-57 #17209..... \$197.95/ea.



1957 BRAKE MASTER CYLINDER CAPS

1957 Numbered..... #14701..... \$27.95/ea.

1957 Un-Numbered #14702..... \$27.95/ea.

BRAKE MASTER CYLINDER CAP GASKET ONLY

1955-57 #1202..... \$2.75/ea.



BILLET MASTER CYLINDER COVERS

All Chromed..... #14984..... \$99.95/ea.

All Brushed..... #14985..... \$75.95/ea.



1957 MASTER CYLINDER AND POWER UNIT COPPER WASHERS

1955-57 #1838..... \$3.95/ea.

1957 MASTER CYLINDER TO FIREWALL GASKET

This fibrous gasket includes perforations that allow it to be installed onto the master cylinder before the master cylinder is installed into the firewall.



1957..... #1837..... \$2.50/ea.



BRAKE MASTER CYLINDER COVER

1955-57 #1953..... \$13.95/ea.

BRAKE BLEEDING SYRINGE



This tool helps speed up the master cylinder bench bleeding process. Just insert the tip in the bottom reservoir ports. Fills the piston bore with clean fluid while pushing out unwanted air. Bench bleeding the master cylinder is required when installing an new master cylinder.

All..... #16940..... \$4.95/ea.

SPEED BLEEDERS



Speed bleeder makes bleeding your brakes easier than ever. Simply replace your original bleeder valves with a one-way ball and check valve design allowing old air and fluid out, then closing between pumps to prevent air from re-entering the system.

All 3/8" x 24 #14500..... \$15.95/pr.
All 10 mm x 1.5..... #14501..... \$14.95/pr.



BRAKE MASTER CYLINDER HARDWARE SET

This hardware set fits original brake master cylinders. Replacement brake master cylinder assemblies and other related parts are shown on this and throughout the Brake section.

1955-58 #2196..... \$29.95/set

MASTER CYLINDER ADAPTER FITTINGS



Made to adapt 1/2-20 to 3/16 inverted flare and 9/16-18 to 3/16 inverted flare.

All..... #14979..... \$18.95/pr.

MASTER CYLINDER ADAPTER FITTINGS



Converts your 3/8-24 fitting master cylinder to GM's 1/2-20 and 9/16-18 lines.

All..... #17153..... \$16.95/pr.



TREADLE-VAC VACUUM HOSE KITS

1955..... #13529..... \$24.95/kit
1956-57 #13530..... \$27.95/kit



POWER BRAKE VACUUM HOSE CLAMPS

Don't settle for modern screw clamps. These spring clamps are the authentic originals.

1955-57 #033..... \$3.50/set

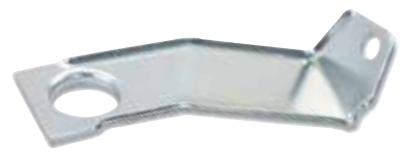

TREADLE-VAC POWER BRAKE HOSE BRACKET

1955-57 #1161..... \$12.95/ea.



TREADLE-VAC PLUNGER ROD SHOULDER BOLT

1955-57 #13528..... \$18.95/ea.



PHOTO COURTESY OF GERTMAN2000



BRAKE WHEEL CYLINDERS

1955-57 Front, Driver	#024.....	\$21.95/ea.
1955-57 Front, Passenger.....	#025.....	\$21.95/ea.
1955-57 Rear, Driver	#026.....	\$19.95/ea.
1955-57 Rear, Passenger	#027.....	\$19.95/ea.



#16326

#16327

REPLACEMENT CROSS-DRILLED AND SLOTTED BRAKE ROTORS

Parts #16325 and #16326 are replacement rotors for our front BIG BRAKE disc brake conversion kits. And the #16327 and #16328 are replacement upgraded rotor for our minimum offset disc brake conversion kits.

All Big Brake Kits, Passenger	#16325.....	\$99.95/ea.
All Big Brake Kits, Driver.....	#16326.....	\$95.95/ea.
All Minimum Offset, Passenger	#16327	\$89.95/ea.
All Minimum Offset, Driver.....	#16328	\$89.95/ea.



BRAKE SHOES

Brand new brake shoes with a premium organic lining. 100% asbestos free.

1951-58 Front Axle.....	#021.....	\$35.95/set
1951-58 Rear Axle (Shown).....	#020.....	\$35.95/set



METRIC FRONT DISC BRAKE PADS

These premium replacement front pads fit our #2700, #2703 as well as the minimum offset disc brake conversions.

1955-57 Semi Metallic (Shown)...	#12322.....	\$39.95/set
1955-57 Organic	#12323.....	\$27.95/set



REPLACEMENT BRAKE ROTOR FOR MINIMUM OFFSET KIT

Replacement rotor for our minimum offset disc brake conversion kits.

All Plain, Replacement.....	#16329.....	\$54.95/ea.
-----------------------------	-------------	-------------



BRAKE SHOE GUIDE PLATE

Goes on the return spring anchor pin.

1955-57	#16838.....	\$5.95/ea.
---------------	-------------	------------

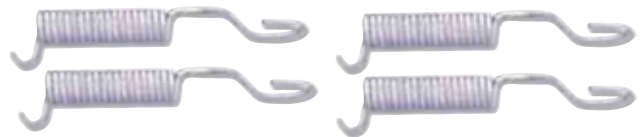

BRAKE SHOE RETURN SPRINGS

Contains four springs, a one axle set.

1955-57	#156.....	\$9.95/set
---------------	-----------	------------



BRAKE DRUM

1951-58 Front or Rear #030..... \$54.95/ea.



CROSS-DRILLED BRAKE DRUM

1951-58 Front or Rear #12821..... \$164.95/pr.



BRAKE DRUM SPRING



Close-Up

This handy little item absorbs resonance that would otherwise be transferred back into the car. Replace this spring when rebuilding the brakes. For use with stock type drums with grooves only.

1955-57 #1503..... \$12.95/ea.

BRAKE PEDAL RETURN SPRING

Installs over the brake pedal cross shaft. The "J" end hooks around the pedal arm and the "L" shaped end hooks under the edge of the support bracket. Brings the pedal back up to resting when the brakes are released..



1955-58 #1883..... \$7.95/ea.



ORIGINAL STYLE METAL BRAKE DRUM HOLE COVERS

1955-57 #1511..... \$5.95/set

BRAKE PEDAL CROSS SHAFT NYLON BUSHING

Use our brake pedal cross shaft nylon bushing to ensure a smooth feel when you step on the brake pedal. If your bushing is damaged or missing, your brake pedal assembly will wobble. This bushing is installed into the brake pedal sleeve on the pedal assembly located under the dash. Two required per car.



1955-57 #2084..... \$6.95/ea.

RUBBER BRAKE HOLE ADJUSTMENT PLUG

Replacement. Four needed per car.

1938-75 #1153..... \$2.95/ea.



RUBBERIZED CLAMP KIT

Used for securing wiring harnesses or fuel lines. 1/2-inch ID, full circle with a 5/16-inch mounting hole. 10 pieces.



All..... #12350..... \$7.95/kit



BRAKE WHEEL CYLINDER PUSH PINS

1955-57 #18354..... \$8.95/pr.

WHEEL CYLINDER FRENCH LOCKWASHER

1955-64 Front Only..... #11228..... \$1.50/ea.





BRAIDED STAINLESS FRONT DISC BRAKE HOSE KITS

Braided stainless hoses give you a firmer pedal feel. Upgrade your disc brakes today with this kit.

- All 16", 10 mm Banjo Bolts..... #15233.....\$69.95/kit
- All 16", 7/16" Banjo Bolt, 1/4" Brake Line #16364.....\$62.95/kit



RUBBER FRONT DISC BRAKE HOSE KITS

Replacement rubber hose kit for front disc conversion kits.

- All 16" w/ 10 mm Banjo Bolt #16363.....\$49.95/kit
- All 16" w/ 7/16" Banjo Bolt, 1/4" Brake Line #16365.....\$49.95/kit



NOTCHED BRAIDED LINE CLAMP KITS

- All -3AN, 1/4", 6-Pack..... #19071.....\$16.95/kit
- All -4AN, 7/16", 6-Pack..... #19072.....\$16.95/kit
- All -6N, 9/16", 6-Pack..... #19073.....\$18.95/kit
- All -8N 5/8", 6-Pack..... #19074.....\$22.95/kit
- All Shop Builder, 56-Pieces..... #19075.....\$179.95/kit



BRAKE HOSE-TO-MOUNTING BRACKET CLIPS

- Set of four.
- 1955-57 #019..... \$8.95/set



#16362



#16361

REPLACEMENT REAR DISC BRAKE HOSES

Replacement hose kits for rear disc conversion kits, rubber or stainless.

- All 16", Rubber w/ 10 mm Banjo Bolt, #16362\$49.95/kit
- All 11", Stainless w/ 10 mm Banjo Bolt #16361\$72.95/kit



REAR DISC BRAKE CONVERSION BRAKE HOSE

Use with late model 10-12 bolt rear end conversions.

- 1955-57 10-12 Bolt Axle #14309..... \$39.95/ea.



DRUM BRAKE HOSES

The only difference from the original is the octagonal hose ends. Each car requires two front hoses and one rear hose.

- 1955-57 Front..... #028..... \$19.95/ea.
- 1955-57 Rear..... #029..... \$25.95/ea.



BRAKE LINE FRAME CLIPS

- 1955-57 Inside Frame #1007..... \$29.95/set
- 1955-57 Outside Frame (Shown) .. #1008..... \$35.95/set

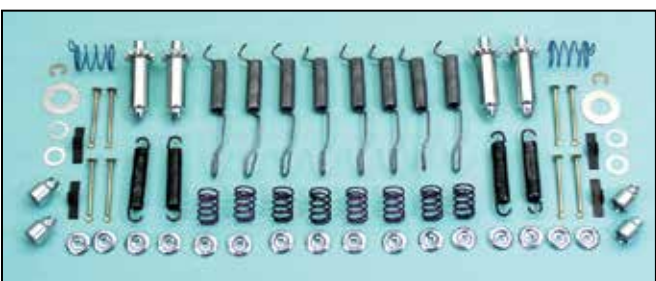

BRAKE HARDWARE KITS

If you're rebuilding your brakes, these complete kits contain the hardware you need to do the job right. Kits include hold-down springs, adjusters, return springs, and all the related hardware to get those brakes working correctly.

- 1951-58 Front & Rear..... #1512.....\$54.95/kit
- 1951-58 Front..... #1512A.....\$33.95/kit
- 1951-58 Rear..... #1512B.....\$33.95/kit



SELF ADJUSTING BRAKE HARDWARE KITS

Update your brake hardware to this time saving self adjusting kit. One kit per axle required, some drilling may be required.

- 1955-57 Front..... #12249.....\$49.95/kit
- 1955-57 Rear..... #12250.....\$49.95/kit



BRAKE HOLD-DOWN KIT

All the springs and hardware needed to complete an axle set.
 1955-57 #158..... \$6.50/set



#1506

#1507

BRASS BRAKE JUNCTION BLOCKS

These brake junction blocks are 100% correct reproductions.

- 1955-57 Rear, '53-62 Vette, Rear #1506..... \$16.95/ea.
- 1955 Front, Driver #1507..... \$16.95/ea.
- 1955 Front, Passenger..... #1508..... \$16.95/ea.
- 1956-57 Front, Driver #1509..... \$16.95/ea.
- 1956-57 Front, Passenger..... #1510..... \$16.95/ea.



BRAKE ADJUSTING SCREW SPRINGS

Includes two springs, a one axle set.
 1955-57 #157..... \$6.95/set



PARKING BRAKE ASSEMBLIES

Each assembly comes completely assembled and includes the mounting bracket with both rollers. Ready to paint and/or install. Parking brake handle is made of steel instead of the original plastic on the #14200 and #14201 and chrome on the #18415 and #18416 .

- 1955-56 #14200.....\$149.95/kit
- 1957..... #14201.....\$149.95/kit
- 1955-56 Chrome Handle (Shown). #18415..... \$179.95/set
- 1957 Chrome Handle #18416..... \$179.95/set



EMERGENCY BRAKE WARNING LIGHT KIT

Like the original accessory, this kit provides a flashing red light when the emergency brake is left engaged.

- 1955-57 #18382.....\$95.95/kit



UNIVERSAL PARKING BRAKE CABLE MOUNT KITS

These brackets allow repositioning your Emergency brake cable attaching points; perfect for configuring any custom application as well as being used to replace lost or broken originals. Includes hardware.

- All..... #18683.....\$21.95/kit



STOP LIGHT SWITCH

Mounts under the dash and contacts the front of the brake pedal. Switch is on when plunger is open, off when plunger is depressed. Light switch should be adjusted to come on when brake pedal has been depressed .62-inch from normal or resting position.

- 1955-57 #116.....\$21.95/ea.



PARKING BRAKE SPREADER BAR

The parking brake spreader installs on the rear drum brakes between the brake shoes.

- 1955-57 #16833.....\$9.95/ea.



BRAKE ADJUSTING SCREW

Sold separately. Four needed per car.

- 1955-57 #159.....\$8.95/ea.



EMERGENCY BRAKE CABLE KITS

Lokar's brake cable kits make it easy to fabricate brake cables when installing non-original rear ends or brake kits. Be sure to order the needed clevis, parts #14821-23, shown below.

All Rear, Universal, Black (Shown)

..... #14819..... \$169.95/kit

All Rear, Universal, Stainless #14820..... \$238.95/kit



LOKAR FLOOR MOUNT EMERGENCY HAND BRAKE BOOTS

Lokar hand brake boots are black neoprene and all sets include a boot, billet aluminum ring with ball-milled edge and stainless screws. Billet aluminum rings also available in black anodized with part #18374.

All Billet..... #18371..... \$69.95/ea.

All Midnight Series Billet #18374..... \$69.95/ea.



LOKAR EMERGENCY BRAKE CABLE KIT, WILWOOD WITH INTERNAL DRUM

All..... #18372..... \$166.95/kit



LOKAR FLOOR MOUNT EMERGENCY HAND BRAKES

Lokar's floor mount emergency hand brake is designed after the automotive industry standard. Ratchet cut gear plate and lock are heat treated for strength and safety. Available in chromed steel or black powder coated steel. Special feature includes 4-point mounting capabilities for floor mount or side mounting for personal applications. Comes complete with clevis for installation with Lokar emergency brake cables. Cables are sold separately. Lever has been designed with durability in mind. Hand brake measures 10-inch from end to end.

All..... #18369..... \$146.95/ea.

All Midnight Series #18373..... \$146.95/ea.



#14822

#14823

#14821

LOKAR EMERGENCY BRAKE CABLE CLEVISES

All Wilwood/88-up Vette Rear Brakes

..... #14821..... \$33.95/pr.

All 84-87 Vette Rear Brakes #14822..... \$45.95/pr.

All Ford Explorer Rear Brakes #14823..... \$45.95/pr.



LOKAR EMERGENCY BRAKE WARNING INDICATOR SWITCH KIT

All..... #18370..... \$43.95/kit



E-STOPP PUSH BUTTON EMERGENCY BRAKE KIT

The E-Stop® push button emergency brake is the perfect E-brake for custom vehicles and winner of the 2012 NSRA new safety product of the year. It not only frees up room on the chassis and in the cab but doubles as an anti-theft device when the button is hidden. It works with any kind of brake system that can accept an e-brake cable and can mount anywhere on the chassis that you have room. The kit comes with the actuator, the control box w/ switch and wire connectors. After market brake cables are required and sold separately. See Lokar brake cable kits, parts #14819-14820, shown on page 471.

All Standard #18286..... \$478.95/kit



E-STOPP CABLE BRACKET

The E-Stop® optional cable bracket can be used to help route and connect your cables to the E-Stop Actuator.

All Machined #18288..... \$37.95/ea.



EMERGENCY BRAKE SHOE LEVER

Kit includes brake shoe levers, shoe spreader bars and hardware. One kit does both sides.

1955-57 #17638..... \$44.95/kit



EMERGENCY BRAKE ADJUSTMENT RODS

1955-57 exc. Convertible (Shown) #1570..... \$45.95/ea.
1955-57 Convertible..... #1571..... \$49.95/ea.



EMERGENCY BRAKE CABLE CLIPS

1955-57 #1504..... \$5.95/set



EMERGENCY BRAKE CABLES 

Original rear brake cables used a boot to keep out dirt and debris which is not necessary on our part #293. **Made in the USA.**

1955-57 Front, Best, exc. Convertible.....	#795.....	\$44.95/ea.
1955-57 Front, Good, exc. Convertible	#16789.....	\$18.95/ea.
1955-57 Front Convertible	#795A.....	\$38.95/ea.
1955-57 Rear (Shown)	#293.....	\$69.95/ea.

EMERGENCY BRAKE ROLLERS

Molded nylon rollers to replace those worn or broken originals. Be sure to order #1591 bolts, shown below.



1955-58 & 55-59 Truck..... #1590..... \$9.95/pr.

EMERGENCY BRAKE CLEVIS

Includes clevis, pin, and cotter key. Goes on the end of the cable coming from the emergency brake cable and hooks onto the idler lever, parts #1592 and #1593, shown at left.



1955-57 #1594..... \$19.95/set

EMERGENCY BRAKE ROLLER BOLTS

Use these special machined shoulder bolts in conjunction with our cable rollers to restore your emergency brake system.



1955-58 & 55-59 Truck
..... #1591..... \$4.95/pr.



EMERGENCY BRAKE LINKAGE RETURN SPRINGS

Attaches between the floor bracket and the emergency brake idler lever.

1955-57 exc. Convertible #1486..... \$8.95/ea.
1955-57 Convertible..... #1487..... \$8.95/ea.



PLATED EMERGENCY BRAKE BRACKET SCREWS

1955-57 #2892..... \$3.95/pr.



EMERGENCY BRAKE IDLER LEVERS

These levers connect the front and rear emergency brake cable.

1955-58 exc. Convertible #1592..... \$19.95/ea.
1955-57 Convertible..... #1593..... \$19.95/ea.

EMERGENCY BRAKE FLOOR BRACKETS

These brackets mount under the floor to the center brace and support the emergency brake idler lever.

1955-57 exc. Convertible #16984..... \$79.95/pr.



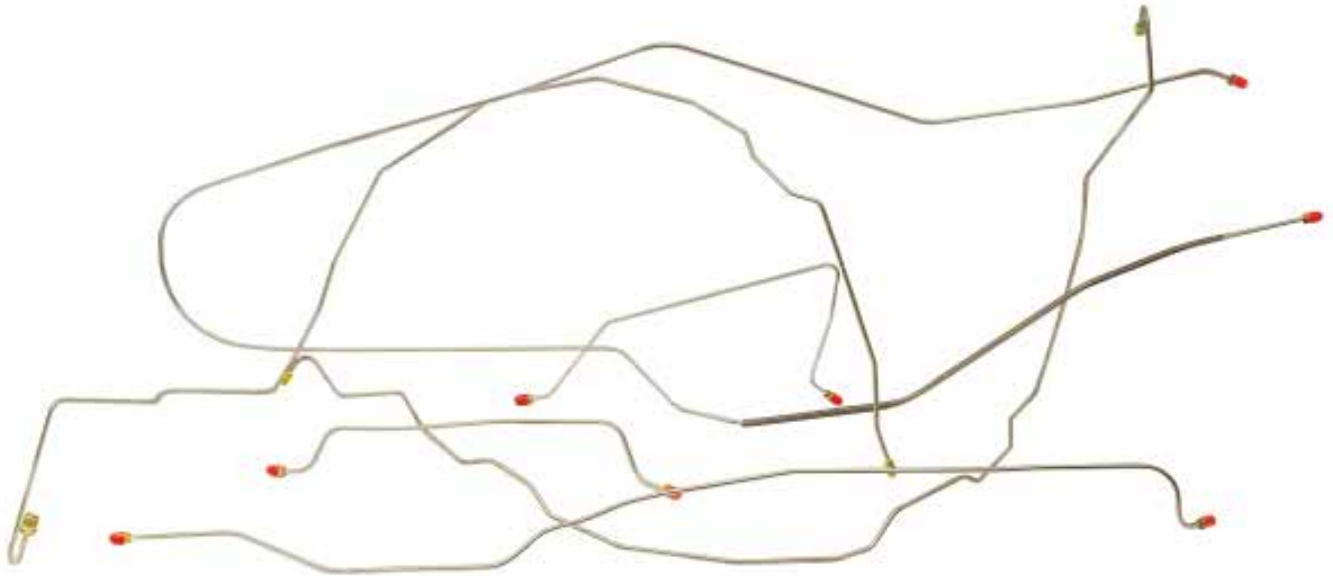

FRONT TO REAR BRAKE LINES FOR DISC BRAKE CONVERSIONS O/S

These kits, available in steel or stainless, cover your braking system from the proportioning valve on your power brake booster to the rear flexible hose and everywhere in between. Front to rear line runs outside the frame.

1955-57 Steel	#10122	\$134.95/set
1955-57 Stainless	#10123	\$179.95/set



BRAKE LINE BRACKET

This bracket will be necessary if you are moving your brake lines to the outside of the frame from the inside of the frame. This supports the line at the rear where it connects to the rear brake hose.

1955-57 4BC, Dual 4BC, Fuel Injection	#1513	\$37.95/ea.
---	--------------------	--------------------

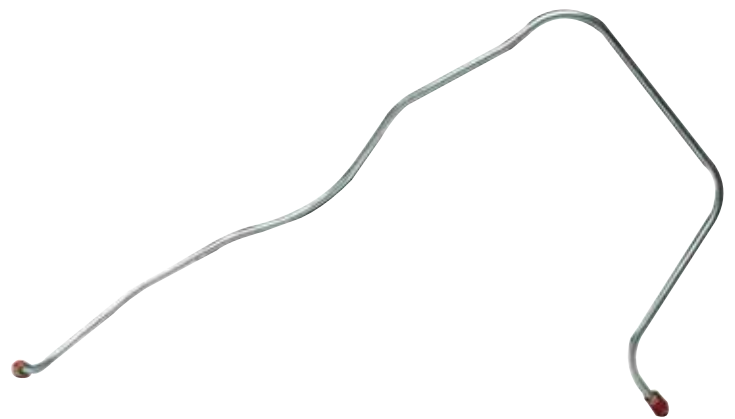

MASTER CYLINDER TO JUNCTION BLOCK BRAKE LINES, NON-POWER

This is the brake line that runs from the master cylinder down to the junction block on the driver side on all non-power applications.

1955	#16259	\$21.95/ea.
1956-57	#16260	\$21.95/ea.

BRAKE LINE CLIP

1955-57 Master Cyl. to Firewall	#11227	\$5.95/ea.
---	---------------------	-------------------



FRONT CROSS MEMBER BRAKE LINE CLIP

1956-57	#18291	\$7.95/pr.
----------------------	---------------------	-------------------



BRAKE LINE AND EXHAUST BRACKET TO FRAME BOLTS

All the bolts you need to attach your brake line junction blocks, brake line bracket and exhaust hanger brackets.

1955-64	#1484	\$9.95/set
----------------------	--------------------	-------------------

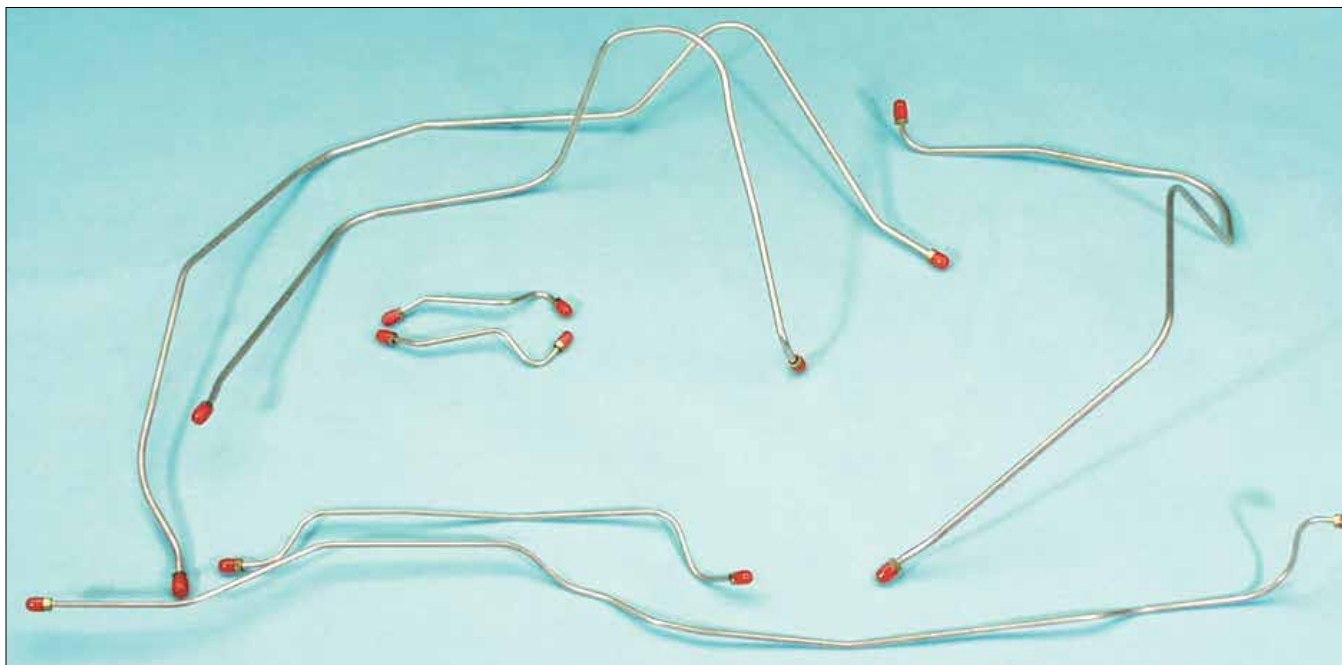

BRAKE LINE SETS

Don't take chances on old, bent brake lines. Our brake lines are reproduced with the original contours and fittings, and include plastic end caps to keep the lines free of moisture and dust until you are ready to install them. Separate front brake line sets were produced for power and non-power systems. Rear brake line sets are common to both systems. **Designed for original front and rear drum brakes.**

1955 Front Set w/out Power	#1464.....	\$58.95/set
1955 Front Set w/ Original Factory Power	#1465.....	\$58.95/set
1956-57 Front Set w/out Power	#1466.....	\$58.95/set
1956-57 Front Set w/ Original Factory Power (Shown)	#1467.....	\$69.95/set
1955-57 Rear Set (Shown).....	#1468.....	\$28.95/set
1955 From Master Cyl. w/ Original Factory Power.....	#1469.....	\$21.95/ea.
1956-57 From Master Cyl. w/ Original Factory Power (Shown)	#1470.....	\$21.95/ea.
1955 6-Cyl., V8 2BC, Inside Frame, Long	#1471.....	\$44.95/ea.
1955 V8 4BC, Outside Frame, Long	#1472.....	\$39.95/ea.
1956-57 6-Cyl., V8 2BC, Inside Frame, Long	#1473.....	\$43.95/ea.
1956-57 V8 4BC, Outside Frame, Long	#1474.....	\$39.95/ea.

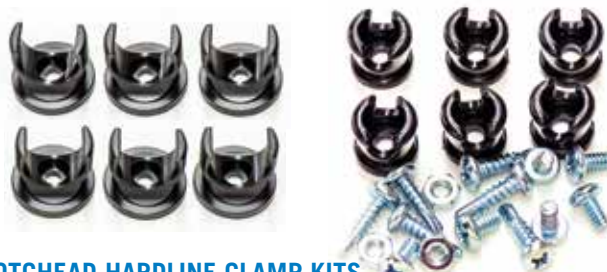
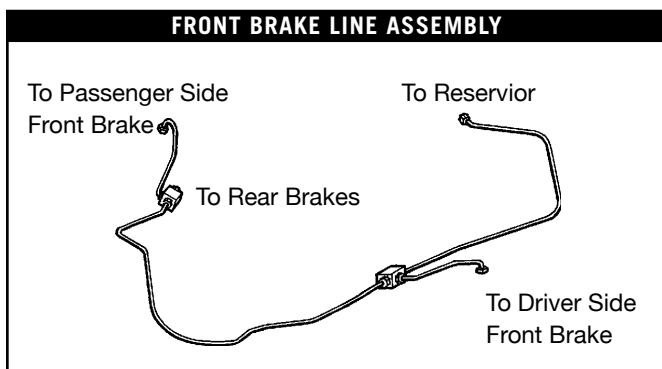

NOTCHEAD HARDLINE CLAMP KITS

All 3/16", 6-Pc.....	#18854.....	\$16.95/kit
All 1/4", 6-Pc.....	#18855.....	\$17.95/kit
All 3/8", 6-Pc.....	#18856.....	\$18.96/kit
All 1/2", 6-Pc.....	#18857.....	\$22.95/kit



1955 FRONT BRAKE LINE CLIP SET

1955.....	#1505.....	\$4.95/set
-----------	------------	------------

NOTCHEAD SOFTLINE CLAMP KITS

All 1/2", Heater/#6 AC, 6-Pc.....	#18858.....	\$22.95/kit
All 5/8", Heater/#8 AC, 6-Pc.....	#18859.....	\$24.95/kit
All 3/4", Heater/#10 AC, 6-Pc.....	#18860.....	\$26.95/kit

WARNING! Products on these pages may contain chemicals known to the State Of California to cause cancer and/or birth defects or reproductive harm. www.p65warnings.ca.gov

ROLLER BEARING CONVERSION KITS

Our conversion kit eliminates the old ball bearings and replaces them with modern roller bearings. Though this is an excellent way to modernize stock wheel applications, it's an absolute must-have for those with custom, non-original wheels. Old-style ball bearings can't withstand the side loads that custom width wheels transmit to the bearing. You can use your stock brake drums and will not notice any changes in front end alignment. Kit comes complete with new hubs, studs, inner bearings, outer bearings, races, grease seals, hub caps, and spindle nut washers. Easy to install. Part #17986 is the same as part #138 except it uses aluminum hubs compared to the cast iron hubs used on the #138.



1955-57 Front, Cast Iron	#138.....	\$259.95/kit
1955-64 Front, Forged Aluminum	#17986.....	\$189.95/kit



REAR AXLE BEARINGS

1955-56	#004.....	\$107.95/ea.
1957 (Shown)	#005.....	\$99.95/ea.



FRONT WHEEL BEARINGS AND OIL SEALS

Outer Bearing:

1955	#001A.....	\$89.95/ea.
1956-57	#001.....	\$59.95/ea.

Inner Bearing:

1955-57	#002.....	\$81.95/ea.
1955-57 Oil Seal, Front Wheel	#003.....	\$15.95/ea.

OE "DISC BRAKE" WHEELS O/S

These OE style disc brake compatible wheels are black powdercoated and use original lug nuts. They accept a small center cap, 10-1/8-inch, that mounts around the center of the wheel as well as the Bel Air full caps. **Check fit before painting. Modified parts cannot be returned. Made in the USA.**

1955-56 15" x 5"	#17704.....	\$167.95/ea.
1955-56 15" x 6"	#17705.....	\$167.95/ea.
1955-56 15" x 7"	#17706.....	\$167.95/ea.
1957 14" x 6".....	#17702.....	\$167.95/ea.
1957 14" x 7".....	#17703.....	\$167.95/ea.



WHEEL COVER SPINNER ASSEMBLY



This complete kit includes four of our beautifully triple chrome-plated wheel spinners, crest emblems and mounting hardware. The spinner assembly is designed to fit 1957-58 Bel Air full size wheel covers. We've also seen these spinners modified to fit other wheel covers. **Made in the USA.**

- 1957-58 Best #578..... \$215.95/set
- 1957-58 Spinner Emblems Only #297..... \$54.95/set



WHEEL COVER SPINNER ASSEMBLY

A very good version of our #578. **Made in the USA.**

- 1957-58 Good #V578..... \$215.95/set



RALLY WHEELS O/S

The rally wheel first appeared in 1968, but it wasn't long before this design became popular among 1955, 1956 and 1957 owners as well. Wheels can be painted to match the color of your car, or even chrome plated. We offer this wheel painted the factory argent silver.

- All 14" x 7" #4464..... \$98.95/ea.
- All 15" x 7" #17645..... \$113.95/ea.
- All 15" x 8" #4465..... \$111.95/ea.



WHEELS FOR USE WITH DISC BRAKES O/S

Accepts full wheel covers and clears disc brakes. Features Chevy and Ford bolt patterns. Hub caps **MUST** be fitted prior to painting.

- 1955-56 15" x 5" #12146..... \$134.95/ea.
- 1957 14" x 6" #12148..... \$129.95/ea.



RALLY WHEEL CENTER CAP 1956 STYLE
All #17649..... \$39.95/ea.



STAINLESS RALLY WHEEL TRIM RINGS
All 14" x 7" #17642..... \$42.95/ea.
All 15" x 7" #17643..... \$42.95/ea.
All 15" x 8" #17644..... \$42.95/ea.



RALLY WHEEL CENTER FLAT CAP
All Stainless #17647..... \$29.95/ea.



RALLY WHEEL CENTER DERBY CAP
All Stainless #17648..... \$51.95/ea.



RALLY WHEEL POLICE CAP WITH BOWTIE
All Stainless #17646..... \$41.95/ea.



1955 SHOW QUALITY GREASE HUB CAPS
1955..... #2185..... \$24.95/pr.



GREASE HUB CAP
Replace those old, dented caps with this original design part.
1956-57 #031..... \$19.95/ea.



WHEEL LUG NUT
Five lug nuts required per wheel.
1955-57 7/16-20 #155..... \$1.95/ea.



WHEEL LUG STUD
Sold individually; Five required per wheel.
1955-57 #154..... \$2.95/ea.



BEL AIR WHEEL COVERS

These replacement wheel covers fit and look like the originals, except for the center crest. They are chrome over stainless and fit original style wheels.

1955.....	#1128.....	\$134.95/ea.
1956 Full	#15559.....	\$131.95/ea.
1957 Full w/o Crest	#15560.....	\$130.95/ea.



150 AND 210 WHEEL COVERS

These gems are available once again. Cannot be used with replacement steel wheels, parts #12146-#12148, sold separately.

1955.....	#1136.....	\$84.95/ea.
1956.....	#1137.....	\$84.95/ea.
1957 w/o Crest.....	#15561.....	\$71.95/ea.



1956 WIRE WHEEL COVER

Add some sparkle to your car with these stylish, stainless steel wire wheel covers. Mounting clips included.

1956.....	#2086.....	\$155.95/ea.
-----------	------------	--------------



1956 WIRE WHEEL HUBCAP RETAINER CLIPS

1956 1-Wheel	#15686.....	\$29.95/set
1956 4-Wheel	#15687	\$99.95/set

BEL AIR HUBCAP DECALS



If you're sporting polished stainless steel hubcaps, you need these. Easier to apply than paint, our hubcap decals are essential to the well-detailed auto. Each decal sheet is made of quality adhesive-backed vinyl. One sheet needed per hubcap.



Made in the USA. 

1955 White	#963.....	\$10.95/ea.
1956 Black (Shown)	#964.....	\$10.95/ea.
1957 Black	#610.....	\$9.95/ea.



American Racing®



TORQ-THRUST RIMS O/S

If these don't bring back memories of "Hot Rodding" in the 60's and 70's we don't know what will. These American-made Torq-Thrust rims are top quality replicas of the originals. If you're looking for a little extra shine, try the 2-piece polished versions. Includes standard center cap. 15-inch x 7-inch wheels have a backspacing of 3-3/4-inch, 16-inch x 7-inch and 17-inch x 7-inch wheels have backspacing of 4-inch and 16-inch x 8-inch and 17-inch x 8-inch have a 4-3/4-inch backspacing. Installation kit sold separately.

All 15" x 7", "D", Gray.....	#10219.....	\$224.95/ea.
All 15" x 7", "D", Chrome	#13055.....	\$311.95/ea.
All 15" x 7", "II", Polished	#10220.....	\$295.95/ea.
All 16" x 7", "II", Polished	#13056.....	\$300.95/ea.
All 16" x 8", "II", Polished (Shown)	#13057.....	\$389.95/ea.
All 17" x 7", "II", Polished	#14567.....	\$318.95/ea.
All 17" x 8", "II", Polished	#14568.....	\$349.95/ea.
All 15" x 7", Original (T.T.O.), Polished.....	#13054.....	\$259.95/ea.



AMERICAN RACING OAKLAND TORQ-THRUST CENTER CAPS

Caps fit Torq Thrust, Salt Flat and Hopster rims.
 All..... #13053..... \$364.95/set



AMERICAN RACING TORQ-THRUST II SHORT CENTER CAP

Caps fit Torq Thrust, Salt Flat and Hopster rims.
 All..... #13052..... \$19.95/ea.



CRAGAR GT WHEELS O/S

Cragar Vintage GT wheels are a one-piece cast design with a 5-spoke center and the Cragar Logo cast into the lip face. Available in chrome or with a grey spoke and machined lip, these wheels are drilled to be used with a conical lug nut. Center cap included, lug nuts sold separately.

All 15" x 7", Chrome	#18583.....	\$320.95/ea.	All 18" x 7", Chrome	#18587.....	\$288.95/ea.
All 15" x 8", Chrome	#18584.....	\$349.95/ea.	All 15" x 7", Grey	#18589.....	\$163.95/ea.
All 17" x 7", Chrome	#18585.....	\$324.95/ea.	All 15" x 8", Grey	#18590.....	\$169.95/ea.
All 17" x 8", Chrome	#18586.....	\$359.95/ea.	All 17" x 7", Grey	#18591.....	\$208.95/ea.



CRAGAR "SS" WHEELS O/S

All 15" x 6", 3-1/4" Backspace	#18506.....	\$224.95/ea.
All 15" x 7", 4" Backspace	#18507.....	\$243.95/ea.
All 15" x 8", 4-1/4" Backspace	#18508.....	\$246.95/ea.
All 17" x 7", 3-3/4" Backspace	#18509.....	\$319.95/ea.
All 17" x 8", 4-1/2" Backspace	#18510.....	\$319.95/ea.
All 17" x 9", 5-1/2" Backspace	#18511.....	\$329.95/ea.

CRAGAR SS TRI-CAR SPINNER WHEEL CENTER CAPS

One of the most popular mods on Cragar wheels is this Tri-Bar bolt on center cap that replaces the originals. Chrome plated aluminum these will take your wheels and your classic up to a new level.

All.....	#19004.....	\$76.95/pr.
----------	-------------	-------------



CRAGAR "SS" CENTER CAP

All.....	#18512.....	\$21.95/ea.
----------	-------------	-------------



AMERICAN LEGEND CRUISER WHEELS O/S

Includes chrome lug nuts and center caps.

All 17" x 7", Argent Silver	#18469.....	\$179.95/ea.
All 17" x 7", Polished.....	#18470.....	\$179.95/ea.
All 17" x 8", Argent Silver	#18471.....	\$179.95/ea.
All 17" x 8", Polished.....	#18472.....	\$179.95/ea.
All 18" x 7", Argent Silver	#18473.....	\$204.95/ea.
All 18" x 8", Argent Silver	#18475.....	\$204.95/ea.
All 18" x 8", Polished.....	#18476.....	\$204.95/ea.



AMERICAN LEGEND STREETER WHEELS O/S

American Legend Streeters, with their beautiful deep-machined lips, are some of the best looking and fitting rims around. They clear most brake upgrades and are available with the traditional polished center. 4.75-inch backspacing is available for #16209 and #16211 by special order. Includes chrome lug nuts and center caps.



These sizes have a 4.25-inch backspacing.

All 17 x 7, Polished	#16208.....	\$189.95/ea.
All 18 x 7, Polished	#16210.....	\$205.95/ea.

These sizes have a 4.5-inch backspacing.

All 17 x 8, Polished	#16209.....	\$189.95/ea.
All 18 x 8, Polished	#16211.....	\$209.95/ea.

These sizes have a 5.25-inch backspacing.

All 18 x 9, Polished	#16368.....	\$254.95/ea.
All 20 x 8.5, Polished	#16369.....	\$254.95/ea.

These sizes have a 5.5-inch backspacing and includes chrome lug nuts and center cap.

All Polished, 20 x 10	#16370.....	\$259.95/ea.
-----------------------------	-------------	--------------



AMERICAN LEGEND RACER WHEELS O/S

Rugged, durable, pressure cast 1-piece construction and detailed finish makes American Legend "Racer" wheels an excellent value for the money. Modeled after the early Halibrand wheels these have the same classic styling but in larger diameters and widths. Available with centers painted in light gray or beautifully polished these are the perfect upgrade to your current wheels. American Legend wheels are precision engineered and manufactured to meet USA, SAE and Australian standards. 4.5-inch backspacing. Includes chrome lug nuts and center caps.

All 17" x 7", Polished.....	#18478.....	\$183.95/ea.
All 17" x 8", Polished.....	#18480.....	\$183.95/ea.
All 18" x 7", Polished.....	#18482.....	\$215.95/ea.
All 18" x 8", Polished.....	#18909.....	\$215.95/ea.
All 18" x 9", Polished.....	#19039.....	\$215.95/ea.
All 17" x 7", Light Gray.....	#18477.....	\$183.95/ea.
All 17" x 8", Light Gray.....	#18479.....	\$183.95/ea.
All 18" x 7", Light Gray.....	#18481.....	\$215.95/ea.
All 18" x 8", Light Gray.....	#19037.....	\$215.95/ea.
All 18" x 9", Light Gray.....	#19038.....	\$215.95/ea.



CHROME VALVE STEMS

All Set of 4..... #18990..... \$6.95/set



CHROME WHEEL LOCK SET

All 7/16"..... #13048..... \$29.95/set



CHROME LUG NUT

All 7/16", Acorn..... #13049..... \$1.95/ea.



CHROME WHEEL INSTALLATION KIT

All 7/16", Acorn..... #13047A..... \$36.95/kit



B.F. GOODRICH SILVERTOWN WHITEWALL RADIAL TIRES O/S

If it's a classic look with a great ride you're after then these radials are your answer. The beautiful 2-3/8-inch white walls will class-up your classic and compliment your show car. Just like your modern day car these radials feel like heaven on the pavement. The 1955-56 application is sized 205/75R15 and replaces the 6:70-15. The 1957 application is sized 205/75R14 and replaces the 7:50-14.

- 1955-56 #872 \$279.95/ea.
- 1957 #873 \$279.95/ea.

RADIAL WHITEWALL TIRES WITH BIAS PLY LOOK O/S



Coker Tire's new American Classic radials are **Made in the USA** and thoroughly tested to ensure superb quality for your collector vehicle. You can trust that American Classic radials are ready for the road, but they're also ready for the show field with beautiful styling whitewall that is built in to the tire from day one. The true whitewall construction, along with the "pie crust" shoulder and vintage-style tread pattern give this tire the original look, while the radial internals make it the perfect choice for a car that will see plenty of miles. **Made in the USA.**

- 1955-56 670/R15, 2-3/4" WW #17881 \$279.95/ea.
- 1957 750/R14, 2-1/4" WW #17882 \$289.95/ea.



B.F. GOODRICH WHITEWALL TIRES O/S

If you don't own a set of these beautiful tires, you are missing out. These genuine B.F. Goodrich whitewall tires are the most original and highest quality we can offer. Next time you need new tires or are just looking to upgrade, you can't go wrong with these babies.

- 1955-56 6:70 x 15, 2-1/2" Whitewall #740 \$209.95/ea.
- 1957 7:50 x 14, 2-1/4" Whitewall #741 \$209.95/ea.

COKER TIRE WARRANTY INFORMATION

Coker Tire guarantees their tires to be free from defects in workmanship and materials for the life of the tread. Adjustment is made on a prorated basis (you pay for the tread used). In some cases tread wear is not an issue. The tires get old and start to crack due to age. Any judgements made regarding a guarantee in this situation is at the sole discretion of Coker Tire based on your purchase date, so be sure to keep your receipt. They are not responsible for tire and tube failure due to improper mounting, mechanical failure or improper alignment of the vehicle. Coker Tire does not offer any guarantee of fitment for any particular purpose and limits its liability to the purchase price of the item. All tires and tubes should be installed by properly trained individuals. Dimensions for tires listed are not scientifically measured and may vary depending on rim widths and inflation. Warranty returns require an RMA number and a valid purchase receipt. **ALL WARRANTIES ARE HANDLED BY COKER TIRE DIRECTLY.** Danchuk does not handle or offer any warranties on tires.