

11. Engine & Trans.

SECTION AT A GLANCE:

Engines & Related	486
Motor Mount	490
Engine Dipsticks.....	493
Timing Chain.....	495
Milodon	496
Oil Pan Related	498
Oil Filter	499
Balancers	500
Crankshaft Pulleys	501
Belts & Pulleys.....	502
Water Pump Pulleys.....	503
Water Pumps.....	504
Pulleys & Brackets.....	505
Bill's Hot Rod Brackets	506
Pulley Systems.....	508
Transmission Mounts	510
Cross Members.....	512
Transmissions.....	513
MSD Controllers	514
Torque Convertor.....	515
Transmission Pans	516
Oil Cooler.....	517
Transmission Dipsticks.....	520
Speedometer.....	522
Shift Linkage	523
Clutch Related	524
Shifters	528
Throttle Cables.....	530
Kickdown.....	531
Neutral Safety Switch	532



EDELBROCK PERFORMER 350 ENGINES

These 9.0:1 compression engines have 320 HP and 382 ft/lbs of torque. Custom assembled by Edelbrock technicians, they include the Edelbrock Performer EPS manifold, 600 CFM carb with electric choke, aluminum heads with guide plates, aluminum valve covers with a custom badge, cast iron crank, cast aluminum pistons and powdered metal rods. They are covered by Edelbrock's 24-month unlimited mileage, zero deductible warranty.

All 320 HP/382 Torque, Cast..... #13205... \$6863.95/ea.

All 320 HP/382 Torque, Polished Package (Shown)

..... #13206... \$7293.95/ea.



EDELBROCK PERFORMER HI-TORQUE 350 ENGINE

Available with a 650 CFM carb, you are assured to get Edelbrock's proven performance and reliability. We offer these in the Endurashine finish for the ultimate in visual impact.

All 363 HP/405 Torque, Single Carb, Endurashine

..... #15138... \$7878.95/ea.



EDELBROCK PERFORMER RPM E-TEC 350 ENGINES

The 9.5:1 compression engines have 435 HP and 435 ft/lbs of torque. Custom assembled by Edelbrock technicians, they include the Edelbrock RPM Air Gap manifold, 800 CFM carb with electric choke, E-Tec heads with guide plates, aluminum valve covers with a custom badge, forged steel crank, hypereutectic pistons, powdered metal rods and Milodon oil pan. They are covered by Edelbrock's 24-month unlimited mileage, zero deductible warranty.

All 435 HP/435 Torque, Cast..... #13209... \$8445.95/ea.

All 435 HP/435 Torque, Polished Package

..... #13210... \$8663.95/ea.



EDELBROCK PERFORMER RPM 350 ENGINES

These 9.5:1 compression engines have 410 HP and 408 ft/lbs of torque. Custom assembled by Edelbrock technicians, they include the Edelbrock RPM Air Gap manifold, 800 CFM carb with electric choke, aluminum heads with guide plates, aluminum valve covers with a custom badge, forged steel crank, hypereutectic pistons, powdered metal rods and Milodon oil pan. They are covered by Edelbrock's 24-month unlimited mileage, zero deductible warranty.

All 410 HP/408 Torque, Cast..... #13207... \$8564.95/ea.

All 410 HP/408 Torque, Polished Package

..... #13208... \$9016.25/ea.

**EDELBROCK/MUSI 555
BIG BLOCK ENGINES**

Edelbrock/Musi 555 crate engines are a powerful big cubic inch package that features the all new Edelbrock E-CNC cylinder heads for the ultimate in Edelbrock performance. E-CNC cylinder heads are fully CNC ported to achieve optimal air-flow for maximum horsepower and torque in high performance street and light duty racing applications. They feature exhaust port exits in the stock location, which allows for the use of off-the-shelf headers. Each engine is assembled by 8-time Pro Street World Champ Pat Musi. They deliver maximum hp and torque on 91 octane fuel. Comes complete with a #2902 Victor Jr. intake, Rolling Thunder #2264 hydraulic roller camshaft, Pro-Flo 2 Electronic Fuel Injection, E-CNC # 79555 cylinder heads and cast aluminum valve covers. Available carbureted or with Pro-Flow 2 EFI.



All Carbureted, 676HP	#18778	\$16674.95/ea.
All Fuel Injection, 697 HP	#18779	\$15808.95/ea.



EDELBROCK PERFORMER 350 V8 ENGINE

This is an affordably priced, entry level small-block Chevy crate engine for any street rod or muscle car driver on a budget that wants affordable 300+ horsepower performance on 87-octane fuel. Edelbrock E-Street crate engines start out with a 100% brand new GM short-block with 4-bolt main and 2-piece rear main seal. This new crate engine features black powder coated intake manifold, carburetor, valve covers and breathers, E-Street cylinder heads, Performer Series carburetor, Performer EPS intake manifold, Performer Series camshaft and quality distributor. E-Street heads are designed for high performance street applications and feature larger than stock intake and exhaust ports to improve engine efficiency. Sold without a water pump.

All 315 HP/381 Torque	#17231 ...	\$6552.95/ea.
------------------------------------	-------------------	----------------------



EDELBROCK PERFORMER 350 ENGINES

These 8.5:1 compression engines have 310 HP and 375 ft. lbs. of torque. Custom assembled by Edelbrock technicians, they include the Edelbrock Performer EPS manifold, 600 CFM carb with electric choke, aluminum heads with guide plates, Elite Series valve covers with a custom badge, cast iron crank, cast aluminum pistons and powered metal rods. They are covered by Edelbrock's 24-month unlimited mileage, zero deductible warranty.

All 310 HP/375 Torque, Cast..... #13203... \$6850.95/ea.

**All 310 HP/375 Torque, Polished Package
..... #13204... \$7281.95/ea.**



GM FLEXPLATE FOR EDELBROCK CRATE ENGINES

This Chevrolet Performance flexplate is an externally balanced unit with a 168-tooth ring gear and a dual 10.75/11.50 inch blot pattern for use with 86-up small blocks with a 1-piece rear main seal. GM #14088761. Not SFI approved.

1986-Up #14261..... \$154.95/ea.



TCI FLEXPLATE

TCI forged flexplates are .035-inch thicker than stock and the starter ring is welded on both sides for added strength. This is a 168 tooth, internally balanced, dual bolt patterned unit with dual GM bolt patterns sized for stock 3/8-inch mounting bolts, but they can be drilled out to 7/16-inch if needed. For use with Chevy V8 engines with a two piece rear main seal. SFI approved. Will not work with cast iron Powerglides or any 6-cylinder applications.

**All 168 Tooth, Internal Balance, Dual Bolt Pattern,
All Chevy V8..... #13023..... \$99.95/ea.**



ARP FLEXPLATE BOLT KITS

ARP Pro Series flexplate bolts are far superior to OEM hardware. Forged from aerospace alloy and heat-treated prior to thread rolling and machining, they feature an exclusive, flat 12-point head design and a larger-than-stock shank diameter for increased strength and improved register.

All SB/BB w/ 2-Piece Rear Seal #18764.....\$22.95/kit

All SB/BB w/ 1-Piece Rear Seal #18765.....\$22.95/kit

All Gen 3/4 LS #18766.....\$36.95/kit

All Gen 3/4 LS w/ TH350/400, 700R4 or 200-4R

..... #18767.....\$39.95/kit

All Gen 5 6.2L LT1 #18768.....\$47.95/kit



EDELBRÖCK TOP END KITS

The Edelbrock Power Package top end kits are dyno matched kits all in one box. Just about everything you need to top off your small or big block Chevy.

1957-87 SB, E-STREET, 315 HP/381 Torque	#18466.....	\$1627.95/kit
1957-87 SB, RPM 410 HP/408 Torque (Shown)	#18467.....	\$2266.95/kit
1965-95 BB, RPM 540 HP/539 Torque	#18468.....	\$2901.95/kit



ARP STAINLESS ENGINE AND ACCESSORY FASTENER KITS

Kits include bolts for intake, oil pan, valve covers, thermostat housing, headers, timing cover, distributor, water pump, fuel pump, and side motor mounts. '87 & newer engines require additional fasteners.

All SB, Hex.....	#13989.....	\$194.95/set
All SB, 12-Pt.	#13990.....	\$194.95/set
All BB, Hex.....	#13991.....	\$214.95/set
All BB, 12-Pt.	#13992.....	\$219.95/set



ENGINE INSTALL KITS

These kits works with all Vortec and most LS engines except LS7. They may not work with LSX heads, and dry sump oil systems. Kits include oil pan, windage tray, oil pick up tube, engine side mount adapters, transmission crossmembers, transmission pads and Fit Rite engine mount adapters and all the mounting hardware. Part #19408 includes cast exhaust manifolds with headpipes, while part #19409 includes headers.

- 1955-57 Manifolds w/Headpipes..... #19408..... \$799.95/kit
- 1955-57 Headers (Shown)..... #19409..... \$1249.95/kit

MOTOR MOUNTS

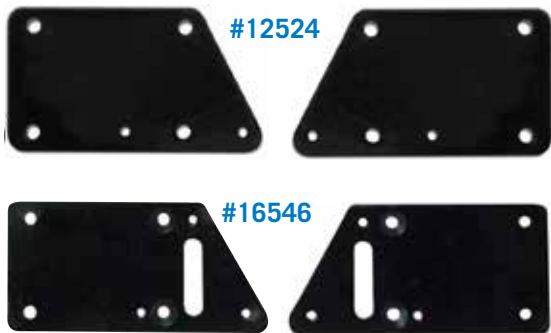

MOTOR MOUNT CONVERSION BRACKETS

For installing an LS1 or LS6 engine into a vehicle that is set up for a Chevy small block V8. Part #16546 is a 1-inch setback LS conversion to move your LS motor 1-inch closer to the firewall, which may be required for additional oil pan and header clearance.

- All..... #12524*\$67.95/pr.
- All w/ 1" Set Back..... #16546.....\$85.95/pr.

*Note: For use with Parts #871 and #976 shown on page 491.



MOTOR MOUNT KITS

Kit includes motor mounts, conversion brackets and hardware. Welding required.

- 1955-57 3/4" Forward..... #12184..... \$179.95/kit
- 1955-57 Standard #12185..... \$179.95/kit



ADJUSTABLE LS ENGINE ADAPTER BRACKETS

These universal adjustable adapter kits allow the engine to move from 1/2-inch rearward (great for oil pan to cross-member clearance) up to 2-1/2-inch forward allowing for a completely custom range of positions. The exclusive design no-weld brackets are CNC laser cut steel and features a durable black powder coat finish. Available with rubber or poly mounts.

- 1955-57 w/ Poly Mounts (Shown). #17758..... \$139.95/pr.
- 1955-57 w/ Rubber Mounts..... #17759..... \$119.95/pr.

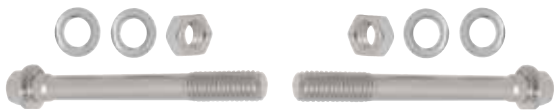

ARP STAINLESS V8 MOTOR MOUNT BOLTS

- All Hex Mount to Block..... #14021..... \$23.95/set
- All Hex Head to Bracket Bolt #14022..... \$23.95/set



MOTOR MOUNT-TO-ENGINE BRACKETS

For stock mount applications use with part #198.
1955-57 V8 Driver..... #251..... \$17.95/ea.
1955-57 V8 Passenger..... #250..... \$17.95/ea.

SIDE MOTOR MOUNT

This side motor mount is for use on all 1958 and later small or big block engines in conjunction with the engine side mount conversion kit, part #871. Mounts on either side of the engine. Two required per car. Sold individually.



1955-57 #976..... \$14.95/ea.



ORIGINAL MOTOR MOUNT SET

Set includes rubbers, washer, and shaft; all parts you need to replace one side. Two sets needed per car.

Made in the USA.

1955-57 V8, 6-Cyl..... #198..... \$38.95/set

MOTOR MOUNT RUBBER CUSHIONS

If your motor mount hardware is in good shape but your rubber mounts are shot, this is the solution for you. Set of four cushions replaces one side. Two sets needed per car. **Made in the USA.**

1955-57 V8, 6-Cyl..... #198A..... \$18.95/set



POLYURETHANE MOTOR MOUNT CUSHIONS

1955-57 Both Sides..... #14225..... \$31.95/set

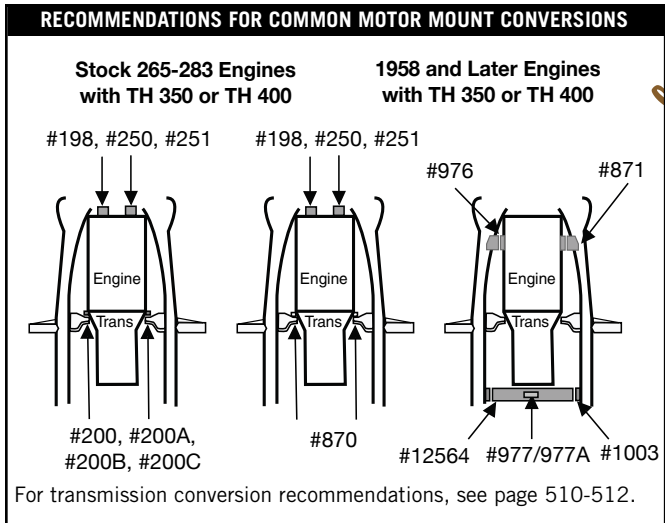

ENGINE SIDE MOUNT CONVERSION KIT

Race-proven and time-tested, this conversion kit is the best way to add modern motor mount strength to 1958 and later small and big block engines. Brackets



are easily welded to the frame, and side motor mounts (part #976 shown at left) are bolted to the block. Please verify frame style before ordering. Part #871 comes with motor mount to bracket bolt only.

1955-57 Seamed Frame, SB, Stock Location

..... #871..... \$69.95/kit



SIDE MOUNT CONVERSION KITS

These updated versions of our #871 series motor mount kits are a true bolt-in kit. Save time and guesswork when converting to side mount and be able to do it with hand tools. Utilizes two of the rivet points in crossmember mounts to mount/locate the brackets to help insure proper placement every time. Fits all frame styles, seamed and seamless.

1955-57 SB, All Frames..... #17756..... \$65.95/kit

1955-57 SB/BB, All Frames, 3/4" (Shown)

..... #17757..... \$65.95/kit

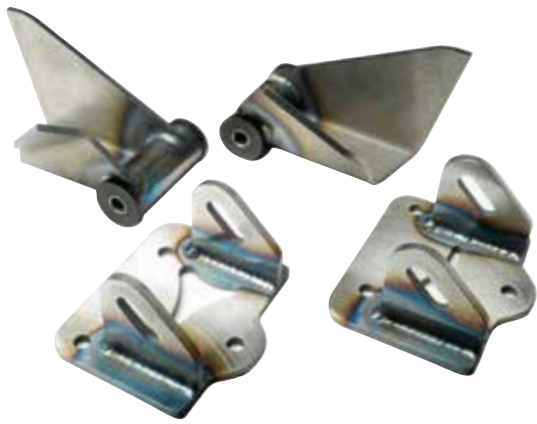

WELD-IN STYLE MOTOR SIDE MOUNT CONVERSION KITS

This design fits both small block (stock and 3/4" forward) and big block engines. Kit includes all the parts to complete the conversion. Welding required.

- 1955-57 SB/BB #16339.....\$274.95/kit
- 1955-57 LS..... #16339A.....\$307.95/kit



POLYURETHANE SIDE MOTOR MOUNTS

Fits with 1955-57 side mount. Polyurethane mounts offer the best of both worlds, smooth running for the street, yet strong enough for the track. Motor mounts also feature safety interlock. Your transmission mount should be the same type as the motor mounts. For a urethane transmission mount that fits autos and standard be sure to order part #15047 or #15048.

- All Zinc #12815..... \$47.95/ea.
- All Chrome #12816..... \$67.95/ea.

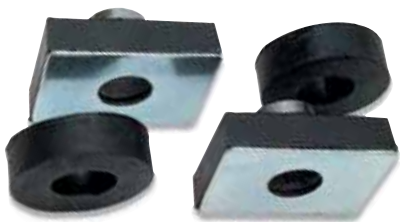

CAB MOUNTS

- 1955-57 Rear Only (Truck)..... #1CAB..... \$27.95/set

BILLET SPECIALTIES MOTOR MOUNT PLATES

Billet Specialties LS Motor Swap Mounts make it easy to put an LS motor in your classic. Multiple mount points allow the bell housing to be located in the same position as the small block in the frame as well as increments of 1/2-inch, 1-3/4-inch and 2-1/4-inch forward for more firewall clearance if needed. Precision machined from 6061-T6 aluminum for strength.



- 1955-57 LS Adj, Black..... #19368.....\$59.95/pr.



ENERGY SUSPENSION LSX MOTOR MOUNT CONVERSION KITS

This set of conversion plates is just what you need if you are installing an LS series engine in your classic Chevy, or any situation where the car is set up to use a standard three bolt motor mount. This set includes two of Energy Suspension's superior Hyperflex polyurethane mounts, adapter plates and all necessary hardware for installation.

- 1955-57 Gold w/ Polyurethane Mounts #16265.....\$135.95/kit
- 1955-57 Chrome w/ Polyurethane #16266.....\$220.95/kit



MOTOR LIFT PLATE FOR LS MOTORS

Bolts in place of the valley cover and includes the mounting bolts and lifting pin-bolt.

- All..... #16545 \$74.95/ea.





#16289

#16290

#16291

#11270

#16290

#16291

#16292

#16293



LOKAR HI-TECH ENGINE DIPSTICKS

1980 & Later SB, Black	#16289.....	\$83.95/ea.
1979 & Earlier SB, Black	#16290.....	\$83.95/ea.
All BB exc. 502, Black	#16291.....	\$83.95/ea.
All 502 BB, Black	#16292.....	\$83.95/ea.
All LSX, Black.....	#16293.....	\$83.95/ea.

LOKAR FLEXIBLE ENGINE DIPSTICKS

Flexible engine dipstick designed with machined aluminum handle to coordinate with Lokar's flexible transmission dipstick. Slim design allows mounting inside headers. Designed for use with factory cast manifolds. E-Z read stainless stick for accurate measure of the engine oil.

1980 & Later SB, Silver	#11271.....	\$75.95/ea.
1979 & Earlier, Silver	#11272.....	\$75.95/ea.
All BB exc. 502, Silver.....	#11273.....	\$75.95/ea.
All 502 BB, Silver	#11274.....	\$75.95/ea.
All LSX, Silver	#15070.....	\$75.95/ea.
1979 & Earlier SB, Dipstick ONLY	#11270.....	\$36.95/ea.



#15077

LOKAR ANCHOR-TIGHT LOCKING ENGINE DIPSTICKS

- 1979 & Earlier SB, Silver..... #15077..... \$109.95/ea.
- 1980 & Later SB, Silver..... #15073..... \$109.95/ea.
- All BB exc. 502, Silver..... #15081..... \$109.95/ea.

- All 502 BB, Silver..... #15085..... \$109.95/ea.
- All LSX, Silver..... #15089..... \$109.95/ea.
- All SB RamJet /Vortec, Silver..... #15093..... \$109.95/ea.

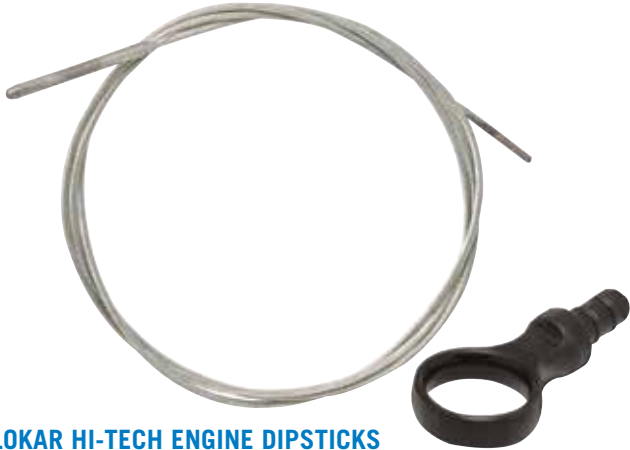

LOKAR HI-TECH ENGINE DIPSTICKS

Lokars "Gauge-to-fit" Dipstick for LS engines is a simple upgrade over the factory plastic handled that not only looks out of place, but can be easily broken. Just use your factory dipstick to measure against and trim the excess and install the billet handle. Available in polished or black.

- All LS1, Polished..... #18280..... \$39.95/ea.
- All LS1, Black..... #18281..... \$39.95/ea.



CHROME DIPSTICKS

Kits consist of both the stick and the tube. Dipstick has the original hook handle. Some modification may be required for trans dipsticks, parts #1977 and 1978.

- 1958-77 SB..... #1975..... \$7.95/ea.
- 1965-91 BB..... #1976..... \$12.95/ea.
- All TH350 (Shown)..... #1977..... \$11.95/ea.
- All TH400..... #1978..... \$11.95/ea.



DIPSTICKS AND TUBES

- 1956-57 Dipstick, V8 & 56-57 Vette 2nd Design..... #10130..... \$18.95/ea.
- 1957-59 Lower Tube, V8..... #10131..... \$21.95/ea.
- 1956-57 Upper Tube, V8..... #10132..... \$13.95/ea.

MILODON ENGINE DIPSTICKS



These engine dipsticks have a unique sleek design. The fittings, stick and hose are all stainless steel and the O-ring sealed handle is billet stainless as well, so they stay bright and rust free even with daily use. **Made in the USA.**



- 1955-79 SB..... #12797..... \$64.95/ea.
- 1986-Up SB..... #12798..... \$64.95/ea.
- All BB..... #12799..... \$69.95/ea.
- All LS1 & LS7..... #14630..... \$69.95/ea.



1955 OIL DIPSTICK TUBE

The 55 V8 block requires this unique, one year only, dipstick tube.

- 1955 V8, Upper Tube..... #13191..... \$13.95/ea.



TIMING CHAIN COVER INSTALLATION KITS

- All SB..... #13393..... \$15.95/kit
- All BB..... #13394..... \$19.95/kit

TIMING TABS

Chrome plated for a perfect match to the timing chain cover.
Note: Parts #1972 and #1974 may be used for some pre-1969 engines by relocating the top dead center on the balancer.



- 1969-91 SB w/ 6-3/4" or 7" Balancer..... #1972..... \$5.95/ea.
- 1969-91 BB w/ 8" Balancer..... #1973 \$4.95/ea.



POLISHED BILLET TIMING CHAIN COVER

- All SB..... #12509..... \$29.95/ea.



TIMING CHAIN COVERS

Produced according to GM standards for reliable installation.
 1969-91 SB #1968..... \$26.95/ea.
 1965-91 BB #1969..... \$11.95/ea.



MILODON TIMING COVER BOLTS

- All Front, V8 #13385..... \$5.95/set



TIMING CHAIN SETS

Performer link timing sets, made by Cloyes, are for use with Edelbrock or stock cams except factory roller cams. True roller timing sets have three keyway settings to ensure accurate timing.



- All SB..... #13150..... \$54.95/set
- All BB..... #13151..... \$55.95/set

MILODON SMALL BLOCK TIMING COVERS

Milodons front timing covers are precision checked for proper placement of seal and dowl pins to avoid leaks. Be sure to order the timing cover installation kits for proper installation.



- All SB, Chrome #16919..... \$17.95/ea.
- All BB, Chrome #16920..... \$28.95/ea.
- All BB, Gold #16921..... \$33.95/ea.



MILODON TIMING CHAIN COVER

- All SB w/ Reinforced Thrust Plate #13392..... \$33.95/ea.



ARP STAINLESS TIMING CHAIN COVER BOLTS

- All Hex, V8 #14011..... \$27.95/set
- All 12-Pt., V8 #14012..... \$28.95/set



OE TIMING COVER SCREWS AND WASHERS

- 1955-57 V8 #1537..... \$8.95/set

WARNING! Products on these pages may contain chemicals known to the State Of California to cause cancer and/or birth defects or reproductive harm. www.p65warnings.ca.gov



#12768



#16996

MILODON

MILODON OIL PANS

Milodon oil pans are designed for street performance and dragstrip applications and will clear stock chassis and steering as well as rack-and-pinion. They clear most header styles. These well engineered pans free up additional horsepower through better oil control which is necessary when high volume oil pumps and high RPM ranges are used. Be sure to order the correct pump, pump pick-up and pan gasket for your application. Low profile gives adequate oil supply and maximum available ground clearance. Will not fit '55 V8's. Parts #12768 and #12769 will work with 1955-57 vehicles with big block engines installed.

Pan Profiles:

#12765-67 Street performance pans offer stock appearance, but with an internal mounted windage tray for better oil control and increased horsepower.

#12768-69 Extra low profile designed specifically for 1955-57 big blocks conversions. Offers adequate clearance even if the motor is moved/forward.

- 1956-1979 SB, Low Profile, 8-1/4", 7-Quart #12762..... \$199.95/ea.
- 1980-85 SB, Low Profile, 8-1/4", 7-Quart #12763..... \$219.95/ea.
- 1986-Up SB, Low Profile, 8-1/4", 7-Quart #12764..... \$219.95/ea.
- 1956-79 SB, Street Performance, 7-1/2", 5-Quart #12765..... \$199.95/ea.
- 1980-85 SB, Street Performance, 7-1/2", 5-Quart #12766..... \$199.95/ea.
- 1986-Up SB, Street Performance, 7-1/2", 5-Quart #12767..... \$199.95/ea.
- 1965-90 BB, 8-1/2", 7-Quart #12768..... \$309.95/ea.
- 1991 BB, 8-1/2", 7-Quart..... #12769..... \$369.95/ea.
- All LS1-LS7, 6" Deep, 7-Quart #14627..... \$369.95/ea.

MILODON OIL FILTER RELOCATION KIT

This Milodon oil filter relocation kit for LS1 and LS7 engines gives you the flexibility to mount the oil filter in any desired location for ease of access or just to gain space for your engine transplant. The kit includes two braided hoses 36-inches long with -AN fittings and an oil filter mount
All LS1 & LS7 #14629..... \$239.95/kit

MILODON REPLACEMENT OIL PANS

These Milodon replacement pans are the perfect replacement for your original pan. Unlike imported chrome pans, Milodon pans have flat unwrapped pan rails for a perfect glove fit. They feature very effective internal horizontal baffles for efficient oil control and their gold irridated finish assures quality and a distinctive look. Drivers side dipstick. Pan holds five quarts, plus the filter. Measures 8-inch deep at the lowest point. Note: These pans require the use of the "thick" oil pan end gaskets. Danchuk #16996 will work on any 1955-1979 small block Chevy engine. Danchuk #16997 will work on any 1986 and up small block Chevy engine and for use with engines that have a 1-piece rear main.

- 1956-79 SB #16996..... \$129.95/ea.
- 1986-UP SB #16997..... \$139.95/ea.

MILODON OIL PAN OIL FILTER MOUNT KIT

This LS oil filter mount kit is exactly what you need when doing that LS conversion in your classic. CNC machined from T-6061 billet aluminum it is designed to mount the oil filter on the pan rail in the stock location allowing you to use the standard LS oil filter or the 40% larger GM filter for maximum filtration. Keeps the filter from haning below the oil pan.

- 1955-57 LS1 & LS7 #18517 \$99.95/kit

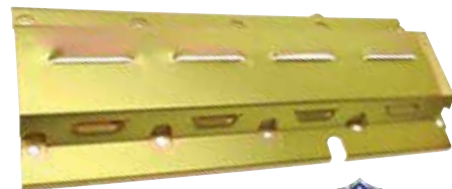

MILODON LS OIL PAN WINDAGE TRAY

- All LS #14631 \$69.95/ea.



MILODON OIL PAN GASKETS

Milodon's one-piece pan gaskets end leaks at the corner where conventional individual pieces meet. These molded rubber gaskets are reusable and have steel inserts at each bolt hole so the pan bolts can be securely tightened yet the gasket can never be overtightened.

- 1956-79 SB exc. '55 V8 #12804..... \$32.95/ea.
- 1986-Up SB #12805..... \$37.95/ea.
- 1965-90 BB Mark IV..... #18752..... \$33.95/ea.
- All BB..... #12806..... \$40.95/ea.
- All LS..... #19041..... \$38.95/ea.

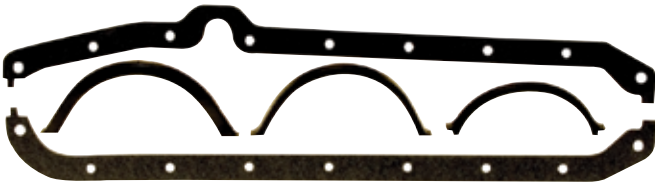

MILODON OIL PAN GASKETS

Milodon's crush-proof pan gaskets will not crush, split, shrink or squeeze out like inferior gaskets. For a leak free pan installation use the right gaskets the first time.

- 1956-85 SB #12784..... \$20.95/ea.
- 1965-85 BB #12785..... \$20.95/ea.



MILODON OIL PUMP PAN BAFFLES

Installs between the oil pump and rear main cap. This baffle prevents oil from climbing up the rear of the pan into the crankshaft during hard acceleration. An easy addition to assure added horsepower.

- All SB..... #12782..... \$9.95/ea.
- All BB..... #12783..... \$9.95/ea.

MILODON OIL PUMP PICK-UP'S

Milodon oil pans require the correct pick-up. Stock pick-up's are too big. Danchuk #18674 is designed for use with Milodon extra low profile pans, Danchuk # 12768 & 12769. Be sure to order the correct one for your Milodon pan.

- All Street Performance Pans..... #12771..... \$50.95/ea.
- All BB (Shown) #12772..... \$56.95/ea.
- All LS..... #14628..... \$100.95/ea.
- All BB for #12678 Pan..... #18674..... \$56.95/ea.



MILODON OIL PUMPS

Milodon hi-volume/hi-pressure pumps provide 20%-30% increase in volume and pressure.

- All BB..... #12773.... \$90.95/ea.
- All SB (Shown) #12774.... \$75.95/ea.



MILODON OIL PUMP PRIMER

Be sure to prime that fresh crate motor or rebuild with this priming tool from Milodon.

- All V8..... #13380..... \$42.95/ea.



MILODON OIL PUMP STUD KIT

A must for your high performance Chevy. Torque to 50 ft./lbs. with oil. Made from 8740 chrome moly steel.

- All SB/BB #12777..... \$9.95/kit



Engine

MILODON



STAINLESS OIL PAN BOLTS

All SB, Hex.....	#13999.....	\$56.95/set
All SB, 12-Pt.	#14000.....	\$59.95/set
All BB, Hex.....	#14001.....	\$73.95/set
All BB, 12-Pt.	#14002.....	\$77.95/set



OIL PAN STUD KITS

1955-85 SB	#12786.....	\$22.95/ea.
All BB.....	#12787.....	\$31.95/ea.
All Auto, TH350, TH400 & PG.....	#13382.....	\$25.95/kit



OE OIL PAN BOLT SET

1955-64, '55-64 Vette	#1536.....	\$11.95/set
-----------------------------	------------	-------------



OE OIL PAN DRAIN PLUG

1955-57 w/ Gasket.....	#15439.....	\$1.25/ea.
------------------------	-------------	------------



REAR AXLE HOUSING/ OIL PAN DRAIN PLUG GASKETS

This gasket will work on both the oil pan and the rear axle housing drain plugs to prevent leaks.

1955-72	#14176.....	\$3.00/pr.
---------------	-------------	------------



1955 OE OIL FILTER LINES WITH FITTINGS

No substitutions here! Original design fittings and bends are combined in these high quality oil lines. Accurately restore the look and function of your lubrication system with this faithful reproduction.

1955 V8.....	#1526.....	\$32.95/set
1955 V8 W/ Factory A/C.....	#19147.....	\$34.95/set



MILODON OIL PUMP DRIVE SHAFTS



This race proven shaft is CNC machined from 4130 chrome moly and eliminates breakage-prone stock units. Good insurance regardless of applications.

All SB.....	#12775.....	\$15.95/ea.
All BB.....	#12776.....	\$15.95/ea.



OIL PAN GASKET SET

1955 265, 55-56 Corvette	#17912.....	\$20.95/set
--------------------------------	-------------	-------------



OIL PAN GASKET SET

1955-57 6-Cyl.....	#18135.....	\$16.95/set
--------------------	-------------	-------------

SMALL BLOCK V8 SPIN-ON OIL FILTER ADAPTER BOLT



Two of these bolts are required to install oil adapter shown above, part #16242.

1968-Up GM.....	#16243.....	\$2.95/ea.
-----------------	-------------	------------

#191



OIL FILTER ELEMENTS #192

It is interesting to note that only 1956 and 1957 V8 engines had integrated oil filter systems. All 6-cylinder and 1955 V8 engines had optional bolt-on units. These unique filters may be rare, but you can always find them at Danchuk.

- 1940-57 6-Cyl., '55 V8..... #191..... \$16.95/ea.
- 1956-57 V8 Long Canister, 7-5/8 . #192..... \$9.95/ea.
- 1958-67 V8 Short Canister, 6-3/4 #192A..... \$8.95/ea.

POWERFILTER OIL FILTERS

These Powerfilter oil filters have fully CNC machined housings and a washable double mesh stainless steel filter elements. Powerfilter oil filters feature quad bypass design to keep unfiltered oil from reaching the engine, O-rings on all sealing joints, 45 micron stainless filter element and a magnet in the base to collect tiny particles. This is the last filter you will ever have to buy for your classic.



- All 86 & Earlier V8 w/ Spin-On Filter..... #15600 \$119.95/ea.
- All Replacement Element, Standard, Large..... #15668..... \$25.95/ea.
- All O-Ring Replacement Kit #15667..... \$19.95/kit

REAR MAIN SEAL

This rubber rear main seal replaces the old rope seal and is much easier to install. Please make sure you offset the ends of the seal so they don't line up with the split between the main cap and block to prevent leaks.



- 1955-58 V8 #10309..... \$36.95/ea.

OIL PRESSURE SENDING UNIT

An excellent replacement to the original, this sending unit is top notch. If your old unit no longer works, this will fix your problem. 1955's will need to change wire terminal.



- 1955-57 #016..... \$9.95/ea.



OE OIL FILTER HOSES

Both the pressure and return hoses, reproduced to the original specifications, are included in this set.

- 1955-57 6-Cyl..... #1491..... \$43.95/set

OIL FILTER BYPASS VALVE KIT

Required with part #16642 when converting from canister type oil filter to spin-on type filters.



- 1956-67 #16643..... \$49.95/kit

OIL FILLER TUBES

Part #1981 is for use on early model small-block intake manifolds. Part #2335 includes return spring bracket.



- All..... #1981..... \$5.95/ea.
- 1956-65 V8 #2335..... \$39.95/ea.

OIL FILTER SPIN-ON CONVERSION KIT

With this conversion kit along with the required By-Pass Valve (part #16643) you can start using the more common and more economical spin-on filter.



- 1956-67 #16642..... \$29.95/kit

SMALL BLOCK V8 SPIN-ON OIL FILTER ADAPTER

This genuine GM adapter is made for 1968 and later GM motors. Works with all factory spin-on oil filters.



- 1968-Up GM..... #16242..... \$52.95/ea.



#14903



#13739



#13741



#13738

PROFESSIONAL PRODUCTS POWERFORCE HARMONIC DAMPERS

The Powerforce line of high performance street dampers are the highest quality, cost effective damper you can buy and are intended for non-SFI performance applications.

All SB, 6-3/4", Internal, Black	#13738.....	\$69.95/ea.
All SB, 6-3/4", External, Black	#13739.....	\$84.95/ea.
All SB, 8", External, Black	#13741.....	\$89.95/ea.
All SB, 6-3/4", Internal, Stainless.....	#14902.....	\$245.95/ea.
All SB 6-3/4", External, Stainless	#14903.....	\$249.95/ea.

PROFESSIONAL PRODUCTS POWERFORCE PLUS HARMONIC DAMPERS

The Powerforce Plus line are intended for racing applications or high performance street use and meet SFI spec #18-1 which means they can be safely revved in excess of 10,000 RPM.



All SB, 6-3/4", Internal..... #13747..... \$169.95/ea.

REPLACEMENT HARMONIC BALANCER

Accepts bolt-on pulleys. Timing mark is in a different location than the original '55-'57 V8. 6-inch balancer features 60 degrees of timing marks with engraved marks every 90 degrees.



All SB, 6", Internal #12601..... \$79.95/ea.

CRANK GEAR INSTALLATION TOOL

Use this tool with the balancer installer making it easy to press on crank gears straight.



All..... #13842..... \$21.95/ea.

HARMONIC BALANCER PULLER/INSTALLER

Works with all GM, Ford and Chrysler engines. This heavy-duty, professional tool equipped with roller thrust bearings, can also be used for steering wheels and pulley installation and removal. Kit includes 7/16"-20, 5/8"-18, and 3/4"-16 adapters and various removal hardware.



All..... #13840..... \$89.95/kit

ARP SQUARE DRIVE BALANCER BOLTS

All SB..... #14032..... \$57.95/ea.
All BB..... #14033..... \$57.95/ea.



OE HARMONIC BALANCER BOLTS

Use with steel bolt-on pulleys.
1955-57 #2891..... \$8.95/set



HARMONIC BALANCER INSTALLATION TOOL

This tool makes installing the balancer simple, just thread the proper end into the crankshaft and then rotate the nut which presses the bearing against the balancer which slides onto the crankshaft smoothly.

All..... #13841..... \$31.95/ea.



1-GROOVE CRANK PULLEY

Add-on pulley fits inside single groove pulleys to run power steering.

All SB, Short Water Pump..... #15031 \$47.95/ea.



2-GROOVE CRANK PULLEY

1955-57 SB, Short Water Pump.... #14986..... \$48.95/ea.

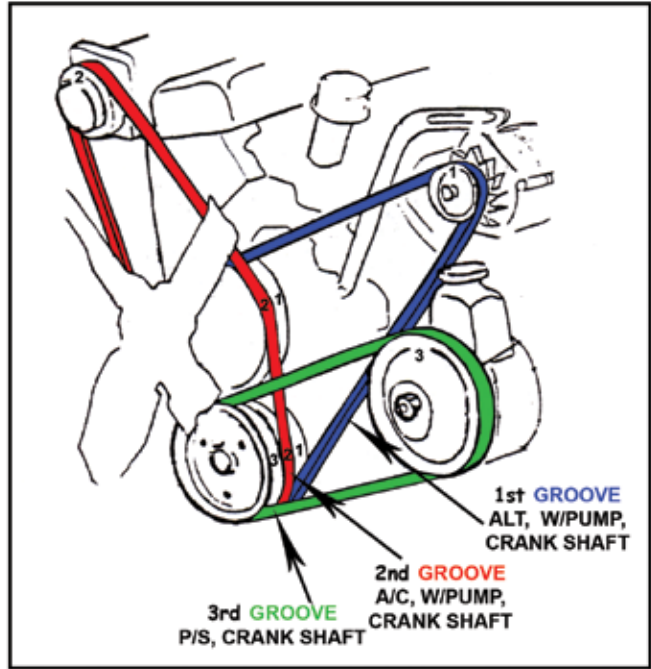

POLISHED BILLET ALUMINUM CRANKSHAFT PULLEY

All BB, 3-Groove, Short Pump #12475..... \$51.95/ea.

CRANK TURNING SOCKET TOOLS

This non-marring aluminum tool fits over the end of the crank when the balancer is removed and allows you to rotate the engine easily with a 1/2 drive ratchet or breaker bar.



All SB..... #13843..... \$21.40/ea.

All BB..... #13844..... \$21.95/ea.



#17053



#17054



#17055



#17056

BILLET SPECIALTIES CRANK PULLEYS

- All SB, Short Water Pump, 2-Groove, Polished #17053..... \$74.95/ea.
- All SB, Short Water Pump, 3-Groove, Polished #17054..... \$82.95/ea.
- All SB, Long Water Pump, 2-Groove, Polished #17055..... \$79.95/ea.
- All SB, Long Water Pump, 3-Groove, Polished #17056..... \$89.95/ea.
- All BB, Short Water Pump, 2-Groove, Polished #17057..... \$84.95/ea.
- All BB, Short Water Pump, 3-Groove, Polished #17058..... \$82.95/ea.



#16337

ALUMINUM CRANKSHAFT PULLEY BOLTS

For use with our aluminum crankshaft pulleys, one set per pulley.

All SB..... #16337..... \$3.95/set

All BB..... #16338..... \$3.25/set



#16336



SHOW QUALITY AIR CONDITIONING BELTS

These belts are made to GM specifications with correct materials, and bear the GM logo as it appeared on original 5-6-7 belts.

1955.....	#2504.....	\$39.95/ea.
1956.....	#2505.....	\$39.95/ea.
1957.....	#2506.....	\$39.95/ea.



DRIVER QUALITY FAN BELTS

High-quality parts are as reliable as they come!

1955-57 6-Cyl. w/ Power Steering	#042.....	\$17.95/ea.
1955-57 6-Cyl. w/o Power Steering (Shown)	#043.....	\$14.95/ea.
1955-57 V8 w/ Power Steering	#040.....	\$18.95/ea.
1955-57 V8 w/o Power Steering	#041.....	\$19.95/ea.



SHOW QUALITY FAN BELTS

Designed to stand up to tremendous heat and friction, these sturdy belts are made to General Motors' specifications with correct materials, and bear the GM logo as it appeared on original 5-6-7 belts.

1955-57 V8 w/ Heavy Duty Generator	#2500.....	\$38.95/ea.
1956 V8 w/ Dual 4BC, RPO 411	#2501.....	\$36.95/ea.
1957 V8 w/ Dual 4BC, RPO 411	#2502.....	\$37.95/ea.
1957 V8 w/ Fuel Injection, RPO 578	#2503.....	\$36.95/ea.
1955-57 V8 w/o Power Steering (Shown)	#2498.....	\$36.95/ea.
1955-57 V8 w/ Power Steering (Shown)	#2499.....	\$36.95/ea.



#17048

#17052

BILLET SPECIALTIES WATER PUMP PULLEYS

All SB, 2-Groove, Short, Polished..	#17048.....	\$79.95/ea.
All SB/BB, 2-Groove, Long, Polished		
.....	#17052.....	\$89.95/ea.
All BB, 1-Groove, Short, Polished..	#18523.....	\$89.95/ea.
All BB, 2-Groove, Short, Polished..	#18524.....	\$89.95/ea.



#12443

#12441

WATER PUMP PULLEYS

1955-68 SB, 1-Groove, Short Pump, 7.08" Diameter	#2278.....	\$18.95/ea.
All SB, 1-Groove, Polished Billet, Short Pump	#12441.....	\$51.95/ea.
All SB, 2-Groove, Polished, Short Pump	#12443.....	\$59.95/ea.
All BB, 2-Groove, Polished, Short Pump	#12469.....	\$49.95/ea.



BILLET SPECIALTIES SHORT WATER PUMP PULLEY NOSE CONE

All SB/BB, Polished.....	#17049.....	\$19.95/ea.
--------------------------	-------------	-------------



BILLET SPECIALTIES LONG WATER PUMP PULLEY NOSE CONE

All Polished.....	#17345.....	\$19.95/ea.
-------------------	-------------	-------------



OE ORIGINAL STYLE WATER PUMP PULLEY

This is a replacement, double groove pulley for power steering and air conditioning conversions.

1955-68 2-Groove, SB, Short Pump
 #12727 \$69.95/ea.



WATER PUMP REBUILD KIT

This rebuild kit includes the impeller, shaft, seals, bearings, gaskets, and fasteners.

1955-57 #1530 \$69.95/kit



POLISHED BILLET WATER PUMP PULLEY NOSES

All Short Pump..... #12449..... \$17.95/ea.
All Long Pump #12465..... \$17.95/ea.



WATER PUMP PULLEY SHIMS

This 3-piece kit helps you to fine tune water pump pulley alignment.

All..... #13722 \$7.95/set

ALUMINUM WATER PUMP PULLEY BOLTS

For use with our aluminum water pump pulley. One set per pulley required.

All SB/BB..... #16336 \$3.95/set



EDELBROCK ALUMINUM WATER PUMPS

Edelbrock water pumps are ideal to prevent overheating in street machines and feature state of the

art cooling technology. These supercooling water pumps provide equal distribution to both sides of the block and flow in only one direction for maximum efficiency. Pumps listed are standard rotation only.

All SB, Short, Satin #13154..... \$269.95/ea.
All SB, Long, Satin #13158..... \$248.95/ea.
All SB, Short, Endurashine..... #13365..... \$346.95/ea.
All SB, Long, Endurashine #13366..... \$338.95/ea.



OE STAINLESS WATER PUMP BOLTS

Rust and corrosion make periodic replacement of these bolts a necessity.

Make sure you replace them when installing a new water pump. Short pumps only.

1955-72 #2244 \$10.95/set



WATER PUMP FITTINGS

1955-56 5/8" #10067 \$17.95/ea.
1957 3/4" #12226 \$11.95/ea.



STAINLESS WATER PUMP BOLT KITS WITH BOWTIE

All SB, Short Water Pump..... #14292..... \$8.95/kit

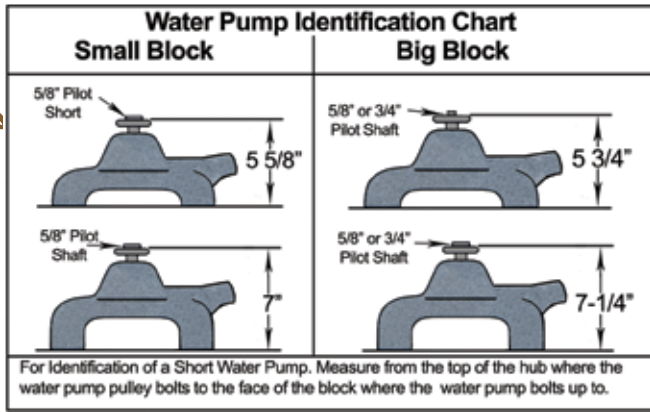

BILLET SPECIALTIES TOP MOUNT AIR CONDITIONER COMPRESSOR BRACKETS

- All SB w/ Short Water Pump (Shown) #18824..... \$125.95/ea.
- All SB Vortec w/ Short Water Pump #18826..... \$146.95/ea.
- All BB w/ Short Water Pump #18828..... \$146.95/pr.



REPLACEMENT WATER PUMPS

These replacement water pumps are brand new and function like the originals.

- 1955-57 6-Cyl. #170..... \$64.95/ea.
- 1955-68 V8 #171..... \$39.95/ea.

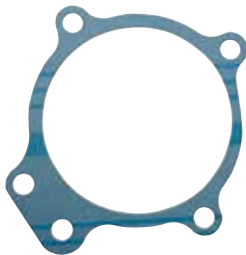

WATER PUMP GASKETS

- All 235 6-Cyl. (Shown)..... #19461..... \$1.45/ea.
- All V8..... #19462..... \$1.55/ea.



BILLET SPECIALTIES TOP MOUNT ALTERNATOR BRACKETS

- All SB w/ Short Water Pump #18825..... \$125.95/ea.
- All SB Vortec w/ Short Water Pump (Shown) #18827..... \$146.95/ea.
- All BB w/ Short Water Pump #18829..... \$125.95/ea.



ARP STAINLESS WATER PUMP BOLTS

- All Hex, All V8 Pumps #14013..... \$36.95/set
- All 12-Pt., All V8 Pumps..... #14014..... \$36.95/set

HEATER HOSE TO WATER PUMP FITTING

- These fittings are for use on small-block and big block water pumps.
- All Chrome, 3/4" V8..... #1961..... \$5.95/ea.



VINTAGE AIR FRONT RUNNER ENGINE COMPONENT DRIVE SYSTEMS

Each system includes a main truss bracket, tensioner, power steering (or power steering delete) bracket, crankshaft pulley, water pump pulley, alternator, high volume aluminum water pump, power steering pump with pulley (with power steering kit), serpentine belt, and hardware kit. Bright finish pulley kits include polished tensioner cover and clutch cover.



FRONT RUNNER COMPLETE COMPONENT KITS

With Power Steering:

All SB, Black	#12535	\$2245.95/kit
All SB, Bright.....	#12537	\$2295.95/kit
All BB, Black	#12535A	\$2380.95/kit
All BB, Bright.....	#12537A	\$2410.95/kit
All LS1/LS6, Bright.....	#15008	\$2925.95/kit
All LS1/LS6, Black.....	#15010	\$2825.95/kit
All LS7, Bright	#15012	\$2925.95/kit
All LS7, Black.....	#15014	\$2825.95/kit

Without Power Steering:

All SB, Bright.....	#12536	\$2105.95/kit
All BB, Black	#12534A	\$2170.95/kit
All BB, Bright.....	#12536A	\$2225.95/kit
All LS1/LS6, Bright.....	#15009	\$2705.95/kit
All LS1/LS6, Black.....	#15011	\$2605.95/kit
All LS7, Bright	#15013	\$2675.95/kit



#12542



#12543

FRONT RUNNER TENSIONER COVER KITS

All Satin	#12542.....	\$42.95/kit
All Polished.....	#12543.....	\$54.95/kit

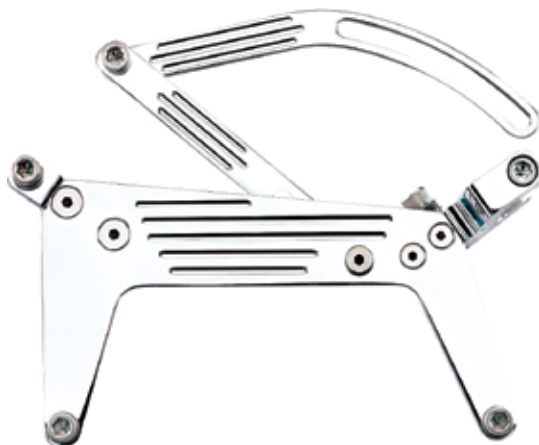

BILLET SPECIALTIES TOP MOUNT AIR CONDITIONING & ALTERNATOR BRACKETS

Designed for use with GM 60 to 80 amp alternators & Sanden 508 AC compressor. This bracket is CNC machined from 6061-T6 billet aluminum and polished to a mirror finish. Ideal for small block Chevrolet motors that do not have mounting holes in the cylinder heads. This bracket mounts to the water pump and intake manifold to ensure stability and belt tension. Designed for use with short water pumps, GM 10SI / 12SI alternator and Sanden 508 AC compressor.

All Polished..... #17045..... \$249.95/ea.

BILL'S HOT ROD BRACKETS

For strength and durability, these brackets are made of 1/4" mild steel plate, finished off in your choice of bare steel, black or chrome plating. Each bracket comes completely assembled, with adjusting arms, all the necessary stainless steel washers and allen head bolts, an illustrated instruction sheet, belt size recommendations and adjusting tips for an easy installation. The alternator used is a GM, and the air conditioning compressor is a Sanden SD-508. Stock steel or aluminum aftermarket pulleys can be used with these brackets.

BILL'S HOT ROD BRACKETS



BILL'S HOT ROD ALTERNATOR BRACKETS

Mounts alternator on driver side.

All SB w/ Late Style Heads, Short Water Pump, Black	#18194.....	\$119.95/ea.
All SB w/ Late Style Heads, Long Water Pump, Black	#18196.....	\$119.95/ea.
All SB w/ Early Style Heads, Short Water Pump, Black	#18198.....	\$149.96/ea.
All SB w/ Late Style Heads, Short Water Pump, Bare	#18205.....	\$124.95/ea.
All SB w/ Late Style Heads, Short Water Pump, Black	#18206.....	\$144.95/ea.
All SB w/ Late Style Heads, Short Water Pump, Chrome	#18207.....	\$199.95/ea.
All SB w/ Late Style Heads, Short Water Pump, Bare	#12546.....	\$99.95/ea.
All SB w/ Late Style Heads, Short Water Pump, Chrome	#12547.....	\$169.95/ea.
All SB w/ Late Style Heads, Long Water Pump, Bare.....	#12548.....	\$99.95/ea.
All SB w/ Late Style Heads, Long Water PumpChrome	#12549.....	\$164.95/ea.
All SB w/ Early Style Heads, Short Water Pump, Bare.....	#12550.....	\$109.95/ea.
All SB w/ Early Style Heads, Short Water Pump, Chrome	#12551.....	\$199.95/ea.
All BB w/ Short Water Pump, Black	#18202.....	\$124.95/ea.
All BB w/ Short Water Pump, Bare.....	#12556.....	\$119.95/ea.
All BB w/ Short Water Pump, Chrome	#12557.....	\$199.95/ea.



ALTERNATOR BRACKETS

This alternator bracket is for use on big-block engines equipped with the long water pump.

All..... #1985..... \$12.95/ea.

For use with small-blocks when converting the alternator to a side mount with headers. Use with #1982 and #1987.

All..... #1986..... \$10.95/ea.

For use on small-blocks with headers and a short style water pump. Use with #1986.

All..... #1982..... \$11.95/ea.

All..... #1987..... \$11.95/ea.



BILL'S HOT ROD AIR CONDITIONING BRACKET ADD-ONS

Use these air conditioning bracket with part #12550, #12551, #12556 and #12557 when adding air conditioning to your classic.

All SB, Bare..... #13718..... \$87.95/ea.

All SB, Chrome

All BB, Bare..... #13720..... \$93.95/ea.

All BB, Chrome

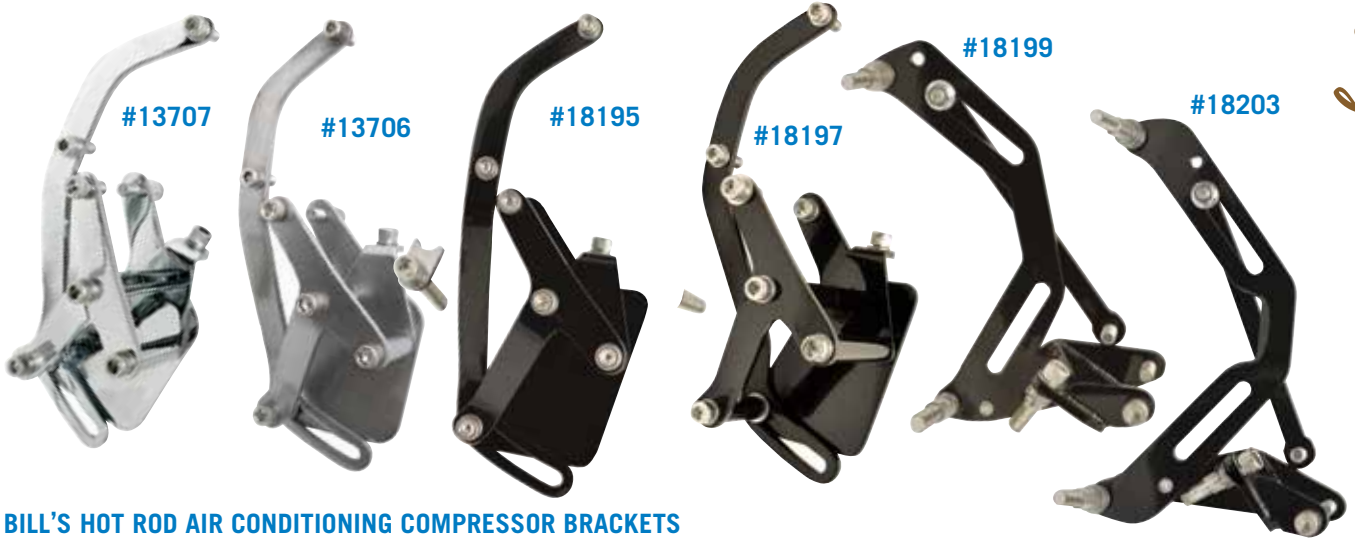

BILL'S HOT ROD AIR CONDITIONING COMPRESSOR BRACKETS

Mounts on passenger side.

All SB w/ Late Style Heads, Short Water Pump, Bare.....	#13706.....	\$99.95/ea.
All SB w/ Late Style Heads, Short Water Pump, Chrome	#13707.....	\$169.95/ea.
All SB w/ Vortec Heads, Short Water Pump, Bare	#13708.....	\$109.95/ea.
All SB w/ Vortec Heads, Short Water Pump, Chrome.....	#13709.....	\$189.95/ea.
All SB w/ ZZ Fast Burn Heads, Short Water Pump, Bare	#13710.....	\$109.95/ea.
All SB w/ ZZ Fast Burn Heads, Short Water Pump, Chrome.....	#13711.....	\$199.95/ea.
All SB w/ Late Heads, Long Water Pump, Chrome.....	#13713.....	\$189.95/ea.
All SB w/ Vortec Heads, Long Water Pump, Bare.....	#13714.....	\$122.95/ea.
All SB w/ Vortec Heads, Long Water Pump, Chrome	#13715.....	\$199.95/ea.
All SB w/ ZZ Fast Burn Heads, Long Water Pump, Bare	#13716.....	\$122.95/ea.
All SB w/ ZZ Fast Burn Heads, Long Water Pump, Chrome	#13717.....	\$199.95/ea.
All SB, w/ Late Style Heads, Short Water Pump, Black	#18195.....	\$119.95/ea.
All SB, w/ Late Style Heads, Long Water Pump, Black	#18197.....	\$119.95/ea.
All BB, Short Water Pump, Black	#18203.....	\$145.95/ea.
All SB, w/ Late Style Heads, Short Water Pump, Plain	#18208.....	\$124.95/ea.
All SB, w/ Late Style Heads, Short Water Pump, Black	#18209.....	\$139.95/ea.
All SB, w/ Late Style Heads, Short Water Pump, Chrome	#18210.....	\$199.95/ea.



BILL'S HOT ROD ALTERNATOR AND AIR CONDITIONING BRACKETS

All SB w/ Early Style Heads, Short Water Pump, Bare.....	#12552.....	\$179.95/kit
All SB w/ Early Style Heads, Short Water Pump, Chrome	#12553.....	\$314.95/kit
All SB w/ Early Style Heads, Short Water Pump, Black	#18200.....	\$219.95/ea.
All BB w/ Short Water Pump, Bare.....	#12558.....	\$219.95/kit
All BB w/ Short Water Pump, Chrome	#12559.....	\$349.95/kit

**BILLET SPECIALTIES
V-TRAC PULLEY
SYSTEM**

Superior engineering, high tech styling, quality components combine to create a compact package for the small block Chevy. V-Trac systems are polished and include a 150 amp alternator with a billet one-piece alternator fan and pulley, natural finish Edelbrock water pump, billet water pump pulley, billet bridge bracket, billet crank pulley, polished ARP 12-point stainless hardware, Sanden SD-7 compressor, billet compressor clutch cover, power steering pump with AN fittings, billet power steering pump pulley, Goodyear Gatorback V-belts and a comprehensive installation manual. Not designed for use with hydro boost brake systems.



#17044

#17042



#17040

All SB, w/ Power Steering & A/C, Polished

..... #17044... \$1395.95/ea.

All BB, w/o Power Steering & A/C, Polished

..... #18823... \$1565.95/ea.

**EDDIE MOTORSPORTS
S-DRIVE
SERPENTINE PULLEY
SYSTEMS**

S-Drive pulley systems offer the latest in serpentine drive systems. They feature all new components and **Made in the USA** billet pulleys and brackets. Components included are: Sanden SD7 compressor, Type 2 P/S pump w/reservoir (remote on LS models), alternator and water pump. LS versions include an ATI damper. All components are matched to take the guesswork out of getting the right parts. Available in either machined satin finish or highly polished. Polished versions include a polished compressor, alternator and water pump. Non-power steering versions and custom colors are available by special order.



- All BB, Polished..... #16659.... \$2195.95/kit
- All BB, Machined..... #16660.... \$2095.95/kit
- All SB, Polished..... #16661.... \$2125.95/kit
- All SB, Machined..... #16662.... \$2025.95/kit
- All LS, Machined..... #16676.... \$2395.95/kit
- All LS, Polished..... #16677.... \$2495.95/kit

**BILLET SPECIALTIES
PREMIUM TRU TRAC SERIES PULLEY SYSTEMS**

Premium Tru Trac Pulley Systems are designed with the discriminating hot rodder in mind. They feature a polished 140 amp alternator, billet alternator fan and pulley, Edelbrock Endurashine reverse rotation water pump (except LS7), billet pulleys and brackets, ARP stainless fasteners, serpentine belt, installation manual and the Billet Specialties patent pending billet aluminum tensioner engineered specifically for the Tru Trac systems. Tru Trac is not designed to be used with hydroboost brake systems.

Black finish available by special order.

All SB, Power Steering & A/C, Polished

..... #17040... \$2395.95/ea.

All BB, Power Steering & A/C, Polished

..... #17041... \$2495.95/ea.

All LS1-LS6, Power Steering & A/C, Polished

..... #17042... \$2779.95/ea.

All LS7, Power Steering & A/C, Polished

..... #17043... \$2779.95/ea.

1955-57 LT4, Black..... #19369... \$2495.95/ea.

1955-57 LS1-6 W/PS & AC, Black

..... #19370... \$3064.95/ea.

1955-57 Tru Trac, SB W/PS & AC, Black

..... #19371... \$2549.95/ea.

1955-57 Tru Trac, BB W/PS & AC, Black

..... #19372... \$2654.95/ea.

1955-57 LS 7, W/PS & AC, Black. #19385... \$3064.95/ea.

VICTORY PULLEY SYSTEMS

The Victory Series pulley systems are designed to keep the accessory drive components within the boundaries of the engine block and are available in either a polished or machined finish. All kits feature Sanden SDT compressor with billet manifold, short style aluminum water pump, 150 amp alternator, all pulleys, covers, brackets, belts and chrome plated hardware. Kits with power steering also include aluminum pump and pulley with mounted billet aluminum mini reservoir.



#14781



#14783

Kit Includes all new components; Tuff Stuff water pump, Maval power steering pump, Sanden style SD7 A/C compressor, Powermaster 140-amp alternator, Gates v-belts, and all necessary stainless steel fasteners. Polished kits include a polished finish A/C compressor and alternator. Colored kits come with natural cast finished components. Specify type of steering (gear box or rack & pinion) when placing your order.

All SB w/ Power Steering, Polished (Shown)	#14781	\$2150.95/set
All SB w/ Power Steering, Machined	#14782	\$2395.95/set
All SB w/o Power Steering, Polished (Shown)	#14783	\$1845.95/set
All SB w/o Power Steering, Machined	#14784	\$1650.95/set
All BB w/ Power Steering, Polished	#14785	\$2245.95/set
All BB w/ Power Steering, Machined	#14786	\$2195.95/set
All BB w/o Power Steering, Polished	#14787	\$1995.95/set
All BB w/o Power Steering, Machined	#14788	\$1700.95/set
All LS w/o Power Steering, Polished	#16518	\$2150.95/set
All LS w/o Power Steering, Machined	#16519	\$1950.95/set
All LS w/ Power Steering, Polished	#16520	\$2495.95/set
All LS w/ Power Steering, Machined	#16521	\$2300.95/set

V-DRIVE PULLEY KITS

The new V-Drive systems from Eddie Motorsports offer the same complete, compact design and simple installation as their S-Drive serpentine drive systems but at a more affordable price. One part number gives you everything you need to accessorize your engine with American made billet aluminum and new, name brand



#18187

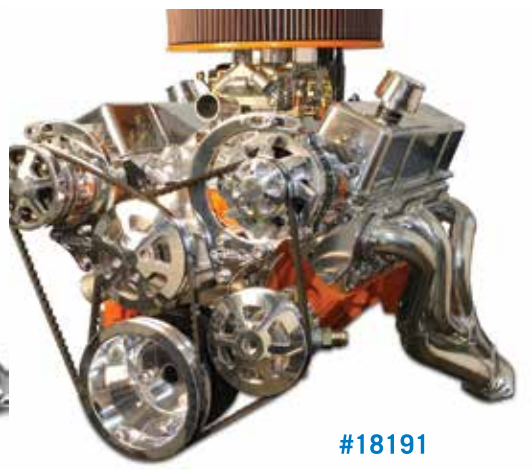

#18191

components. Also available for big block applications. Kit Includes all new components; Tuff Stuff water pump, Maval power steering pump, Sanden style SD7 A/C compressor, Powermaster 140-amp alternator, Gates v-belts, and all necessary stainless steel fasteners. Polished kits include a polished finish A/C compressor and alternator. Colored kits come with natural cast finished components. Specify type of steering (gear box or rack & pinion) when placing your order.

All SB w/ Plastic Power Steering Reservoir, Polished	#18187	\$1495.95/kit
All SB w/ Plastic Power Steering Reservoir, Gloss Black	#18188	\$1575.95/kit
All SB w/ Billet Power Steering Reservoir, Polished	#18189	\$1670.95/kit
All SB w/ Billet Power Steering Reservoir, Gloss Black	#18190	\$1790.95/kit
All SB for Remote Power Steering Reservoir, Polished	#18191	\$1395.95/kit
All SB for Remote Power Steering Reservoir, Gloss Black	#18192	\$1495.95/kit

WARNING! Products on these pages may contain chemicals known to the State Of California to cause cancer and/or birth defects or reproductive harm. www.p65warnings.ca.gov

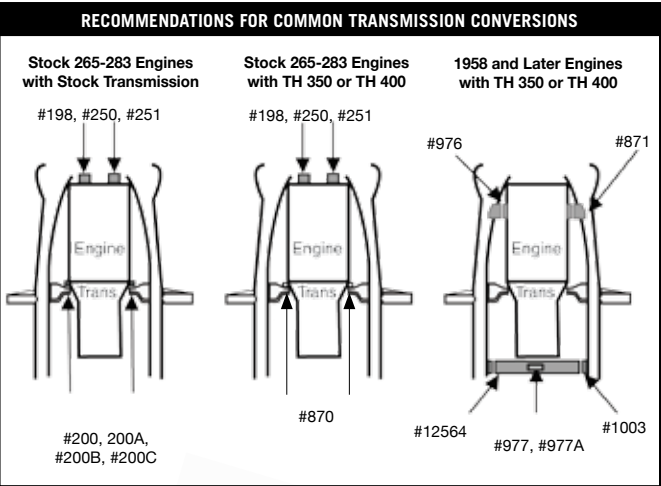

OE TRANSMISSION MOUNT TO FRAME BOLTS
 1955-57 All #15419..... \$3.95/set



OE TRANSMISSION MOUNT TO BELL HOUSING BOLTS
 1955-57 Standard #15417 \$2.95/set
 1955-57 Powerglide..... #15418 \$2.95/set



ARP STAINLESS STEEL BELL HOUSING BOLT KITS
 ARP stainless bell housing bolts are designed to securely attach your transmission bell housing to your engine block.

All Hex.....	#18756.....	\$32.95/kit
All 12-Pt.	#18757.....	\$38.95/kit
All LS, Hex	#18758.....	\$59.95/kit
All LS, 12-Pt.....	#18759.....	\$59.95/kit



TRANSMISSION MOUNTS

1955-57 Auto, Driver (Shown).....	#200.....	\$21.95/ea.
1955-57 Auto, Passenger	#200A.....	\$21.95/ea.
1955-57 Standard, Driver	#200C.....	\$21.95/ea.
1955-57 Standard, Passenger (Shown)	#200B.....	\$21.95/ea.
1955-57 TH350, 700R4, 200-4R & All 4-Speeds	#977A.....	\$14.95/ea.
1955-57 TH400	#977.....	\$14.95/ea.



URETHANE TRANSMISSION MOUNTS
 Urethane mounts feature a safety interlock design and are impervious to oils and chemicals. They are strong for hi-performance use, yet soft enough for a smooth operation.

All Auto & Standard, Zinc.....	#15047.....	\$36.95/ea.
All Auto & Standard, Chrome	#15048.....	\$74.95/ea.



- A: Upper Brackets (1 rh, 1 lh)
- B: Upper Bracket Spacers (4)
- C: Lower Brackets (1 rh 1 lh)
- D: Rubber Bushing (4)
- E: Bolts (2)
- F: Flat Washers (4)
- G: Nuts (2)

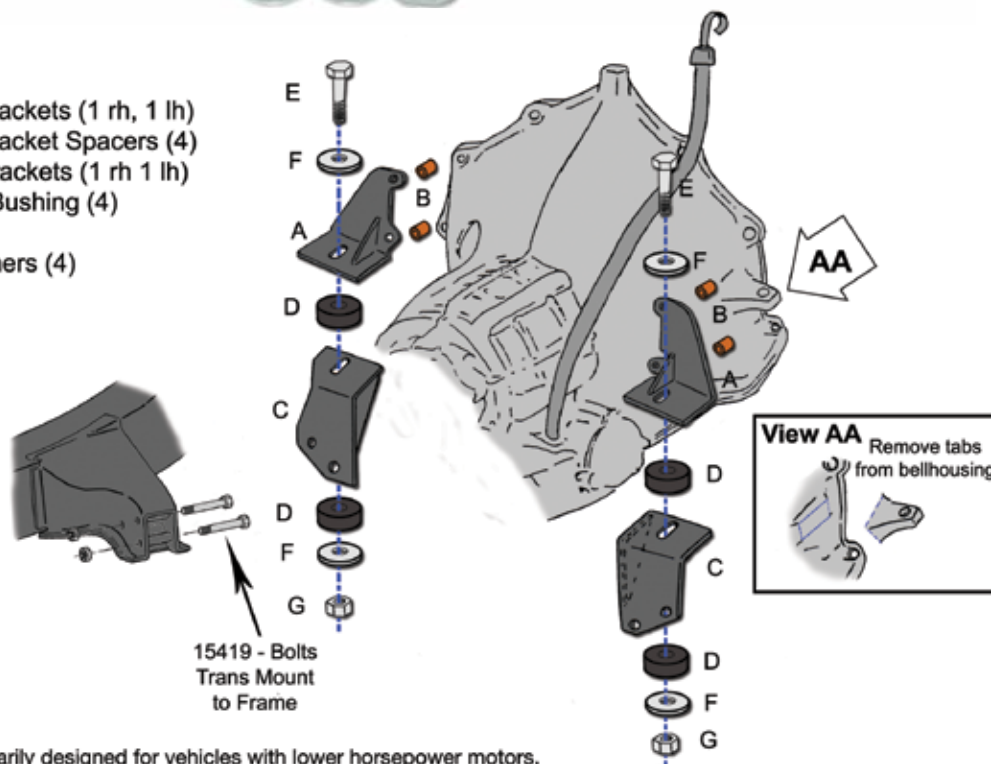

This kit is primarily designed for vehicles with lower horsepower motors.

TRANSMISSION SIDE MOUNT CONVERSION KITS

This conversion kit makes mounting the TH350, 400 and 700R4 transmissions a breeze. (This kit will also fit late model Chevrolet transmissions, such as the 200-4R, with minor modifications.) Engineered to last, our conversion kit is built with components that far exceed the strength that is required of them. Rubber cushioned to absorb shock and vibration. Easy to install; simply bolt it to the frame. Must use with front factory motor mounts. Not recommended for high performance applications. **Made in the USA.**

1955-57 TH350, TH400, 700R4, 200-R4	#870.....	\$119.95/kit
1955-57 Hardware Only.....	#870A.....	\$27.95/kit



TRANSMISSION CROSS MEMBERS

Unless otherwise noted these work with TH350, TH400, 700R4, 200-4R, and 4L60-4L80 transmissions (these we know for sure, there may be more). Part #12564 needs transmission cross member end brackets #1003, shown below. Parts #12196 through #12199 end brackets require welding for installation. For complete installation, use transmission mounts #977 or #977A, shown on page 510.

1955-57 Convertible Only, Aluminum Powerglide & TH350 Only	#875A.....	\$59.95/ea.
1955-57 Rear, exc. 5 & 6-Speed, Black	#12564.....	\$99.95/ea.
1955-57 5 & 6-Speed, Bare.....	#12196.....	\$199.95/ea.
1955-57 Bare.....	#12198.....	\$134.95/ea.
1955-57 Powdercoated Black.....	#12199.....	\$229.95/ea.



TUBULAR TRANSMISSION CROSS MEMBER

The best of both worlds, hassle-free installation and mega exhaust clearance. The unique drop of this crossmember allows oversized exhaust pipes to tuck up high between the frame rails. Its balanced NO-weld design makes installation easy. No need to juggle the mounts, crossmember, transmission and brackets at the same time, simply rest the crossmember and brackets on the frame and transmission on the crossmember. Bolt it all down after it is centered between the rails. This fits all GM transmissions with popular 2-bolt mount.

1955-57	#14789.....	\$109.95/kit
---------------	-------------	--------------



TRANSMISSION CROSS MEMBER END BRACKETS

Required when using part #12564. Hardware not included. Made in the USA.

1955-57	#1003.....	\$18.95/pr.
---------------	------------	-------------



CALIFORNIA PERFORMANCE TRANSMISSIONS 

Built by California Performance Transmissions, home to Hot Rod Hall of Famer Art Carr, Danchuk carries a transmission for every need. The 200-4R transmissions have long been a great transmission for street rods and with the addition of an overdrive gear it can give you better mileage, lower cruise RPM, up to 300% longer engine life. Another benefit is the 200-4R is the same length as a TH350 and cast iron Powerglide. This means the stock driveshaft from your original cast iron Powerglide can be reused by just changing the slip yoke (See #11295). The gear shift and cooler lines are located the same as the TH350 so hook up is easy with off the shelf parts. For cooler lines see (# 1551/1597/2191) and shift linkage kit #11283 for column shift. The 200-4R uses a throttle valve cable and bracket that hooks to your carburetor or throttle body and gives you control over your shift points. The #18981 TH350 transmission comes with the six-inch long tail. It is the same size as a manual set up or powerglide so you can use your existing driveshaft without cutting, just change the yoke. The #18981 can handle an engine which puts out between 250 and 400 HP. The #18984 can handle an engine which puts out up to 400 HP. And the #18985 can handle an engine which puts out between 400 and 500 HP. All are excellent choices when choosing a GM transmission to put into your classic. Truck freight shipping required.

All 200-4R, 400-500 HP	#16966.....	\$1995.95/ea.
All 200-4R, 200-400 HP	#16967.....	\$1499.95/ea.
All TH350 with 6" Tail, 250-400 HP	#18981.....	\$1249.95/ea.
All 700R4, up to 400HP	#18984.....	\$1699.95/ea.
All 700R4, 400-500HP	#18985.....	\$2149.95/ea.



DRIVE SHAFT YOKE
1955-57 27 Spline, Muncie, Aluminum Powerglide, TH350, 700R4 & 200-4R..... #11295..... \$101.95/ea.

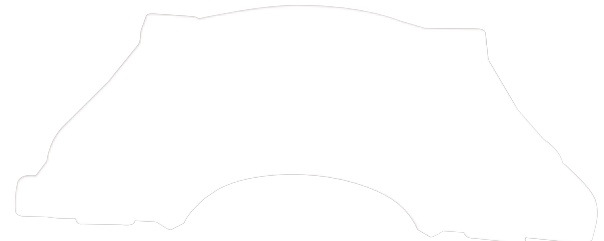

UNIVERSAL DUST COVER
This plastic universal converter cover has guide templates for various starter location cut-outs and slotted mounting holes to fit.
All 700R4 & 200-4R..... #16974..... \$39.95/ea.



UNIVERSAL JOINT
This heavy-duty universal joint comes complete with retainer clips; two required per car.
1955-57

#007.....	\$15.95/ea.
-----------	-------------



TCI DRAIN PLUG KIT
All Universal..... #13039..... \$8.95/kit



PAINLESS PERFORMANCE PERFECT TORC TRANSMISSION CONTROLLER

This is a stand alone controller for 4L60E-4L85E electronic transmissions which allows installation without the need for the stock computer.

All 4L60E-85E #17424..... \$653.95/ea.



MSD ATOMIC TCM TRANSMISSION CONTROLLER

MSD's Atomic stand-alone transmission controller allows you to modify the operating parameters of your GM 4-speed automatic transmission 4L60/70/85E. Includes: controller, monitor, and auxiliary harness. Transmission harness sold separately. See parts #17815-16.

All 4L60/70/85E #17813..... \$684.95/ea.

MSD ATOMIC BRAINWAVE TRANSMISSION CONTROLLER

MSD's Brainwave transmission controller is designed for cars using MSD Atomic EFI systems. Transmission harnesses are sold separately, see parts #17815-16.

All..... #17814..... \$484.95/ea.



MSD ATOMIC TRANSMISSION CONTROLLER HARNESSES

Required harness to connect MSD's transmission controllers #17813-14

2006-09 4L60/70/85E #17815..... \$189.95/ea.

2009-Up 4L70 #17816..... \$159.95/ea.

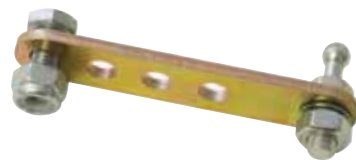

TRANSMISSION OR THROTTLE CABLE EXTENSION KIT

All..... #13355..... \$10.95/kit

#18986



#18982

CALIFORNIA PERFORMANCE TRANSMISSIONS TORQUE CONVERTERS



- All TH350/400, 12" 2200 Stall #18982..... \$289.95/ea.
- All TH350/400, 10" 2600-2800 Stall #18983..... \$559.95/ea.
- All 700R4, 12" 2200 Stall #18986..... \$289.95/ea.
- All 700R4, 10" 2600-2800 Stall #18987..... \$559.95/ea.

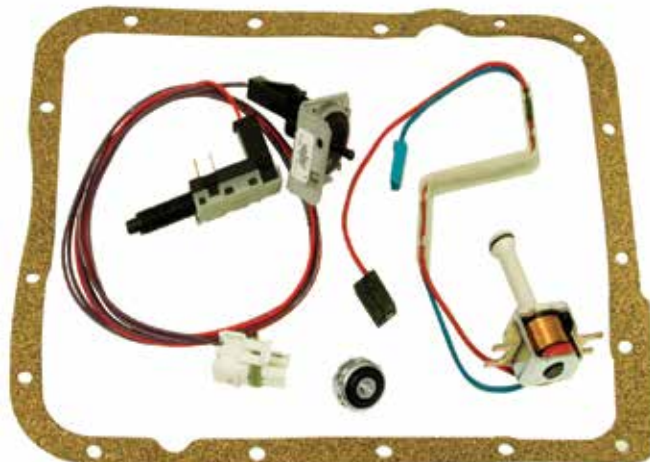

TORQUE CONVERTER LOCK-UP KITS

Now you can control the lock-up function on your over-drive transmission with your carbureted engine and not have to buy any expensive computer. A vacuum controlled switch and a fourth gear pressure switch/lock up solenoid combination controls the lockup. Kit comes complete with everything to complete the installation including a new pan gasket.

- All 700R4..... #14604..... \$236.95/ea.
- All 200-4R #14605..... \$208.95/ea.

200-4R NON-LOCKUP TORQUE CONVERTERS

The revolutionary Street Converter (2000-2200 RPM stall speed) came from research and development of off road competition. These converters offer a slightly higher stall speed that will allow greater torque bands at medium and high speeds, and increased lock-up at higher RPM ranges. In addition there's an increase in fuel mileage at cruise speed. The 10-inch converter is recommended for vehicles in excess of 450hp. You'll get 52 extra horsepower over stock converters with the HD Super Torque converter. Heavy duty converters feature; furnace brazed, 4130 steel turbine hubs, billet stator caps, 3 Torrington bearings and balanced within 5 grams.



- All 10", Heavy Duty #16968..... \$589.95/ea.
- All 12" #16976..... \$289.95/ea.



TRANSMISSION INSPECTION PLATE COVER

- 1955-57 #16091..... \$9.95/ea.

ARP TORQUE CONVERTER BOLT KITS

ARP torque converter bolts are manufactured from 8740 chromoly steel and feature 200,000 psi tensile strength.



- All 3/8-24, TH350/400 #18760..... \$25.95/kit
- All 7/16-20, TH350/400 #18761..... \$17.95/kit
- All 3-Piece M10X1.5, 700R4, 200-4R/kit #18762..... \$18.95/kit
- All 6-Piece M10X1.5, 700R4, 200-4R #18763..... \$34.95/kit



TORQUE CONNECTOR LOCK-UP SWITCH

This wire and switch kit allows the installation of computer controlled transmissions without all the work involved to install the computer control unit.

- All 700R4 & 200-4R #12347 \$79.95/ea.

OIL PANS



PML ALUMINUM DEEP TRANSMISSION PANS

Help make your transmission last longer with a deep sump transmission pan. By adding an additional 2 to 2.5 quarts of fluid this helps keep transmission temps down while the cooling fins help dissipate heat. Available for most popular transmissions.

All 200-4R, Cast.....	#17393.....	\$239.95/ea.
All TH350, Cast.....	#17394.....	\$229.95/ea.
All TH400, Cast.....	#17395.....	\$229.95/ea.
All 700R4/4L60E, Cast.....	#17396.....	\$234.95/ea.



TCI CAST ALUMINUM TRANSMISSION PANS

These are designed with cooling fins to help dissipate heat faster. They require no modifications for installation. Pans include drain plug, fluid pick up extension, when required, pan gasket and new bolts and washers. 2-quart extra capacity.

All TH400.....	#13036.....	\$179.95/ea.
All TH350.....	#13037.....	\$185.95/ea.
All 700R4.....	#13038.....	\$199.95/ea.

TRANSMISSION OIL PAN

We offer two styles of transmission oil pans to match your vehicle. All pans have a ribbed pattern making these parts real beauties. Flawless chrome plating produces a transmission pan that's smooth and brilliant. Fluid is easily changed through the chrome drain plug, included with each pan.

All 700R4 w/o Logo	#2288	\$20.95/ea.
--------------------------	-------------	-------------



ARP STAINLESS TRANSMISSION PAN BOLTS

All 12-Pt, TH350/400	#14031	\$31.95/set
----------------------------	--------------	-------------



TRANSMISSION OIL COOLER LINES 0/8

As with our fuel and brake lines, our transmission oil cooler lines are reproduced to original specifications with correct contours and dimensions. **Note:** 200-4R and 700R4 applications may require slight bending on the transmission side. If your car has a stock 6-cylinder core support, use our #1597 transmission oil cooler lines. If using a stock V8 core support, use our #1551 lines. Cooler line clips included.

1955-57 6-Cyl. Powerglide	#1548.....	\$53.95/set
1955-56 V8 Powerglide.....	#1549.....	\$44.95/set
1957 V8 Powerglide	#1550.....	\$44.95/set
1957 V8 Turboglide	#1598.....	\$41.95/set
1955-57 SB, TH350/400, Engine Side of Core Support (Shown).....	#1551.....	\$44.95/set
1955-57 SB, TH350/400, Grille Side of Core Support.....	#1597.....	\$53.95/set
1955-57 BB, TH350/400 (Shown)	#2191.....	\$44.95/set
1955-1957 700R4 6-Cyl. Position.....	#19140.....	\$44.95/set
1955-1957 700R4 V8 Position	#19141.....	\$44.95/set



HEAT SINK STYLE TRANSMISSION COOLERS

These all aluminum two-pass Heat Sink cooler kits use both external and internal fins to maximize heat transfer. They are 3-inch in diameter with the inlet and outlet ports on the same end. Kit comes with a complete transmission cooler hardware kit to easily install onto vehicles with 5/16-inch transmission cooler lines, making it a perfect solution for light duty transmission cooling needs.

All 12" (Shown).....	#19464.....	\$89.95/kit
All 15".....	#19465.....	\$94.95/kit



TCI TRANSMISSION COOLER

TCI's transmission cooler is a must-have for any transmission. Measures 15-1/2-inch x 7-1/2-inch x 3/4-inch. 18,000 GVW rating.

All Universal.....	#13219.....	\$64.95/ea.
--------------------	-------------	-------------



TRANSMISSION OIL COOLER MOUNT KIT

All.....	#13464.....	\$11.95/kit
----------	-------------	-------------

TRANSMISSION OIL COOLER LINE CLIPS

The only way to hold your new transmission oil cooler lines in position is with these correct clips.



1955-57	#1552.....	\$3.95/pr.
---------------	------------	------------

TRANSMISSION OIL COOLER LINE FITTINGS

1955-57	#034.....	\$9.95/pr.
---------------	-----------	------------





TRANSMISSION COOLER

DERALE STACKED PLATE TRANSMISSION COOLER KITS

With Deraled's top of the line 10000 Series stack plate cooler, -6AN aluminum fittings and hose barb adapters, this highly efficient kit extends transmission life by preventing heat-related transmission failures while also improving shifting performance. This kit comes with a complete transmission cooler hardware kit to easily install onto vehicles with 5/16-inch transmission cooler lines.



All 10-Row	#18490.....	\$104.95/kit
All 16-Row	#18491.....	\$129.95/kit
All 19-Row	#18492.....	\$149.95/kit



DERALE STACKED PLATE SCOOP COOLER

Deraled Performance's Scoop Cooler is another industry exclusive, using Ram Air technology to force-feed air to their highly-efficient 10-Row stack plate cooler. As expected from the Deraled team, it can be used for a wide variety of cooling needs from engine and transmission to power-steering and fuel. Featuring a unique mounting bracket that sandwiches the cooler and the intake scoop, there are a wide variety of mounting options, all of which are designed to provide a clean, attractive and highly efficient cooler. Cooler equipped with 7/8-inch-14 (-10AN) inlet/outlets. -6 AN available, but sold separately.

All 10-Row	#18484.....	\$149.95/ea.
------------------	-------------	--------------

DERALE STACKED PLATE COOLER BRACKETS

Pair of single stacked plate brushed aluminium brackets. Kit includes fastener hardware.

All Single	#18489.....	\$64.95/pr.
------------------	-------------	-------------

Pair of dual stacked plate brushed aluminium brackets. For use when installing two coolers side-by-side. Kit includes fastener hardware.

All Dual	#18488.....	\$77.95/pr.
----------------	-------------	-------------





DERALE PLATE AND FIN TRANSMISSION COOLER KITS

Very popular with original equipment manufacturers for use on their towing applications, our plate and fin coolers feature strong furnace-brazed construction, 1-1/4-inch wide plates and embossed turbulators which maximize heat transfer while also minimizing pressure drop. It greatly extends transmission life by preventing heat-related transmission failures. Built with 1/2-inch NPT female cooler ports and includes 1/2-inch NPT x 3/8-inch hose barb adaptors. This kit comes with a complete transmission cooler hardware kit to easily install onto vehicles with 5/16-inch transmission cooler lines.

All 5-Row	#18493.....	\$79.95/kit
All 9-Row	#18494.....	\$82.95/kit
All 13-Row	#18495.....	\$84.95/kit



DERALE STACKED PLATE COOLER ADJUSTABLE BRACKETS

Set of full length black powdercoated mounting brackets for use with Derale stacked plate cooler line. Kit includes bolts, nuts and washers.

All.....	#18487.....	\$39.95/pr.
----------	-------------	-------------



DERALE STACKED PLATE COOLER BRACKET KIT

Set of four black powder coated mounting brackets for use with Derale stacked plate cooler line. Unique design allows four plane mounting and kit includes bolts, nuts and washers.

All.....	#18486.....	\$18.95/kit
----------	-------------	-------------



DERALE STACKED PLATE COOLER FITTING

Cooler fittings for Derale fluid coolers.

All -6AN-10AN.....	#18485.....	\$10.95/ea.
--------------------	-------------	-------------

Transmission

MILODON STAINLESS TRANSMISSION DIPSTICKS

These transmission dipsticks have a unique sleek design. The fittings, stick and hose are all stainless steel and the o-ring sealed handle is billet stainless as well so they stay bright and rust free even with daily use. The stainless dipstick is pre-calibrated with the required "Add" and "Full" levels. Can be mounted to either firewall or transmission bell housing. **Made in the USA.**



LOKAR ANCHOR-TIGHT LOCKING TRANSMISSION DIPSTICKS

Anchor-Tight dipstick assemblies are NHRA accepted and feature a locking mechanism to eliminate dipstick blowout under transmission pressure. The flexible tube also has a bolt-in sealed case fitting to prevent leaks even further and the larger filler tube accepts standard funnels so there's no need to carry around an adapter.

- All TH350/400, Black #15098..... \$153.95/ea.
- All 700R4, 3" Firewall Mount, Silver #16228..... \$169.95/ea.
- All 200-4R, 3" Firewall Mount, Silver #16229..... \$169.95/ea.

DIPSTICKS

- All TH350..... #12801..... \$110.95/ea.
- All TH400..... #12802..... \$104.95/ea.
- All 700R4..... #12803..... \$104.95/ea.

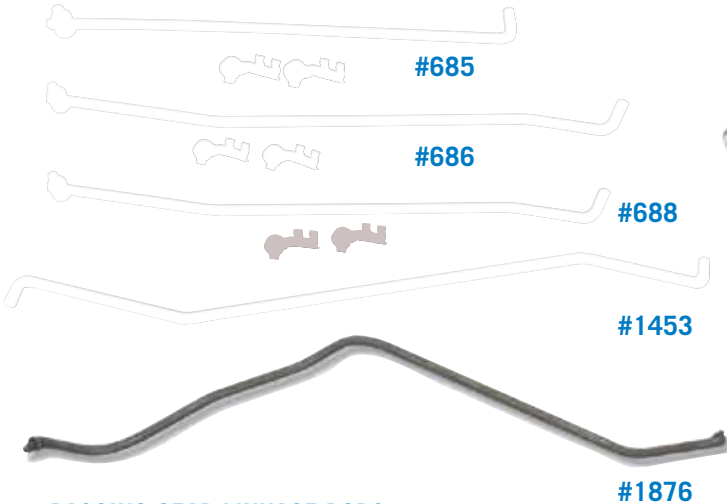

CHROME TRANSMISSION OIL DIPSTICKS

- All TH350..... #1977..... \$11.95/ea.
- All TH400..... #1978..... \$11.95/ea.

PASSING GEAR LINKAGE RODS

- 1955-56 Upper, V8 2BC, 9-1/2" ... #685..... \$24.95/set
- 1955-56 Upper, V8 4BC, 10-3/4" . #686..... \$24.95/set
- 1957 V8 Upper, 2BC, 11-1/2" #687..... \$24.95/ea.
- 1957 V8 Upper, 4BC, 12-5/8" #688..... \$24.95/set
- 1955-57 Upper, 6-Cyl., 12-3/4" ... #1453..... \$24.95/ea.
- 1955 Upper, Early Model 4BC, 7-1/2" #2199..... \$24.95/set
- 1955-56 Lower (Shown) #1876..... \$34.95/ea.
- 1957-62 Lower..... #1884..... \$16.95/ea.



LOCKING TRANSMISSION DIPSTICK AND TUBE

- All Chevy Engine, 200-4R..... #16975..... \$49.95/ea.



#15067



#15068



#15069



#16286



CLOSE UP

LOKAR HI-TECH TRANSMISSION DIPSTICKS

You can have unlimited flexibility with the teflon-lined flexible braided stainless transmission dipstick. Kit comes complete with braided stainless outer housing and heat resistant E-Z to Read Teflon inner rod. Inner rod is stamped with appropriate transmission fluid levels. Machined aluminum handle and aluminum fittings compliment Lokar's flexible engine dipstick. Firewall mount is recommended for 55-56-57's. Designed for "push-in" style transmission. Kit includes complete instructions.

All TH350/400, Firewall Mount.....	#11260.....	\$108.95/ea.
All TH350, Transmission Mount.....	#11261.....	\$101.95/ea.
All TH400, Transmission Mount.....	#11263.....	\$101.95/ea.
All 700R4, Firewall Mount.....	#11264.....	\$108.95/ea.
All 700R4, Transmission Mount.....	#11265.....	\$101.95/ea.
All 200-4R Firewall Mount.....	#14155.....	\$108.95/ea.
All Aluminum Powerglide, Firewall Mount.....	#11266.....	\$101.95/ea.
All Aluminum Powerglide Only, Trans. Mount.....	#11267.....	\$101.95/ea.
All 4L60, Firewall Mount.....	#15067.....	\$108.95/ea.
All 4L60E, Firewall Mount.....	#15068.....	\$108.95/ea.
All 4L80E, Firewall Mount.....	#15069.....	\$108.95/ea.
All LS 1997 & Later SB.....	#15070.....	\$75.95/ea.
All TH350/400, Firewall Mount, Black.....	#16286.....	\$118.95/ea.
All 700R4, Firewall Mount, Black.....	#16287.....	\$118.95/ea.
All 200-4R, Firewall Mount, Black.....	#16288.....	\$118.95/ea.



#18813



#18815



#18820



#18818

#18821



#18817



#18816

LOKAR BILLET DIPSTICK HANDLES WITH INNER CABLES

Replaces the loop on the end of your engine or transmission dipsticks. Complete with double o-rings and an E-Z-Read flexible inner cable. Will NOT work with Anchor-Tight dipsticks.

All 9-Ball.....	#18813.....	\$20.95/ea.	All Deco.....	#18818.....	\$20.95/ea.
All Bullet.....	#18814.....	\$20.95/ea.	All Solid Round.....	#18819.....	\$20.95/ea.
All Keg.....	#18815.....	\$20.95/ea.	All 8-Ball.....	#18820.....	\$20.95/ea.
All Shift Lever.....	#18816.....	\$20.95/ea.	All Piston.....	#18821.....	\$20.95/ea.
All Venetian.....	#18817.....	\$20.95/ea.			



ENGINE STARTER PLATE

If you want to put a TH350/400 transmission in your 1955-56 with a 265 V8 and would like to continue using the stock starter, then this is just what you'll need. Requires 168 tooth flex plate. 1957's will require '55-'56 style starters. Will also work with 700R4 and 200-4R transmissions. Note: Can also be used on 1957 with broken starter mounts. **Made in the USA.**

1955-56 #10100..... \$159.95/ea.



SPEEDOMETER GEARS

This gear goes on the speedo drive that gets inserted into the transmission and are color coded. Match color to original. For use with original powerglides and 3-speed transmissions only.

- 1955-56 Red w/ 21 Teeth, Powerglide #15542..... \$11.95/ea.
- 1957 Blue w/ 20 Teeth, Automatic #15543..... \$11.95/ea.
- 1955-57 White w/ 25 Teeth, 3-Speed w/ Overdrive #15545..... \$11.95/ea.
- 1955-57 Green w/ 22 Teeth, 3-Speed except Overdrive #15544..... \$11.95/ea.

SPEEDOMETER SENSOR LEADS

If you are looking for a speedometer sensor plug for your late model overdrive conversion, look no further.



- All 700R4..... #13678..... \$18.95/ea.
- All 4LE60/4LE80..... #13679..... \$18.95/ea.
- All 4L60..... #13680..... \$18.95/ea.

SPEEDOMETER CONVERTER

The Dakota Digital Electronic Cable Drive allows the use of a mechanical-cable speedometer to be used in conjunction with a modern drivetrain which provides only an electronic output. Quiet operation from the powerful motor allows the user to place the module inside the cabin or the waterproof case allows it to be mounted under the hood, or even inside a fenderwell. Simple calibration with a remotely-mounted switch means there are no DIP-switches to hassle with; access to ECD module is not required! Industry-standard 'measured-mile' calibration as well as speed adjustment while driving, based on a GPS or other known-speedometer reading, keep setup ultra simple.



All Electronic Signal-Cable Drive

..... #18676..... \$304.95/ea.

SPEEDOMETER CABLE WITH CASING

A heavy duty casing with threaded ends protects this well made cable. GM made this replacement cable and casing a bit longer than the original, but it functions identically. Fits most standard and auto transmissions.



1955-57 #228..... \$63.95/ea.

SPEEDOMETER CABLE

This is a replacement cable and does not include casing. It's a bit longer than the original, but easy-to-follow instructions make installation a snap. Fits both standard and automatic transmissions.



1955-57 #227..... \$31.95/ea.



TURBO HYDRA-MATIC SHIFT LINKAGE KIT

Here's what you need to keep stock steering column shifting when converting to the TH350 or 400. Proper contours correctly follow the floor and work in conjunction with our transmission conversion kit. Plated hardware and a powder coated finish make this linkage resistant to rust and corrosion, and as beautiful to look at as it is to operate. **Made in the USA.** See part #11283, above right, for overdrive transmissions.

1955-57 TH350/400 #952.....\$32.95/kit



ADJUSTABLE COLUMN SHIFT LINKAGE ARM KIT

All TH350/400, 700R4, 200-4R ... #11283.....\$58.95/kit



#2358A



#2359



#2358



#2359A

SHIFT DETENTS

These shift detents make using your stock style steering column with your new, or existing, transmission a breeze. Our #2358 and #2359 cover any applications that are using the original "Powerglide" and #2358A and #2359A cover later model transmissions like the TH350 on up to the 700R4. **Made in the USA.**

1955-56 Powerglide..... #2358..... \$18.95/ea.

1955-56 TH350/400, 700R4, 200-4R
..... #2358A..... \$18.95/ea.

1957 Powerglide #2359..... \$18.95/ea.

1957 TH350/400, 700R4, 200-4R #2359A..... \$18.95/ea.



SHIFT INDICATOR WIRE RODS

These reproductions are made with original gauge wire, and all bends and contours are accurate . . . that's quality you can rely on.

1955-56 Auto..... #936..... \$6.95/ea.

1957 Auto (Shown)..... #936A..... \$5.50/ea.



SHIFT LINKAGE ADJUSTMENT SWIVEL NUT

Automatic transmissions require one, while standards require two.

1955-57 #1175..... \$10.95/ea.



SPEEDOMETER CABLE WITH SPIRAL HOUSING

1955-57 70" #17418..... \$17.95/ea.

SHIFT COLUMN LEVER LINKAGE BUSHING

Just a little wear on this important bushing and your shift linkage will feel sloppy. Replacing this bushing will solve the problem and may spare you from more repairs.

1955-57 #1178..... \$6.95/ea.



Transmission



#15416

SHIFT LINKAGE HARDWARE KITS

1955-57 3-Speed Standard..... #15415.....\$18.50/kit
 1955-57 Auto Powerglide #15416.....\$19.95/kit

CLUTCH RELATED



#2262

#12035

#17147

SHIFT LINKAGE RETAINING CLIP

1955-70 #2262.....\$1.50/ea.

SHIFT LINKAGE BELL CRANK BUSHING

Two required per car.

1955-57 #12035.....\$2.50/ea.

DETENT SLIDE BUMPER

This snaps into a hole on the shift arm and contacts the back of the shift detent for smoother shifting. For automatic applications only.

1955-57 Auto Trans..... #17147.....\$3.50/ea.

TRANSMISSION LINKAGE GROMMETS

These are rubber linkage grommets in the bell crank area of the transmission linkage. Replacing these rubber parts will help to reduce the play in the shift linkage.



1955-57 Standard #1792.....\$4.95/set

CLUTCH PEDAL CROSS SHAFT SPACER

This small ring fits on the end of the clutch pedal cross shaft and acts as a spacer between the cross shaft sleeve and splined bellcrank arm.



1955-57 #16982.....\$3.95/ea.

CLUTCH PEDAL SHAFT BUSHING

Two bushings per car needed. Also fits 1964-72 Chevilles. **Made in the USA.**



1955-57 #352.....\$3.95/ea.

Just because your car is 60 years old you don't have to settle for a clutch that will not operate smoothly. Virtually all the necessary parts to completely rebuild your clutch linkage are available from Danchuk Manufacturing. Inspect your clutch assembly closely and give us a call.

1955 CLUTCH LINKAGE

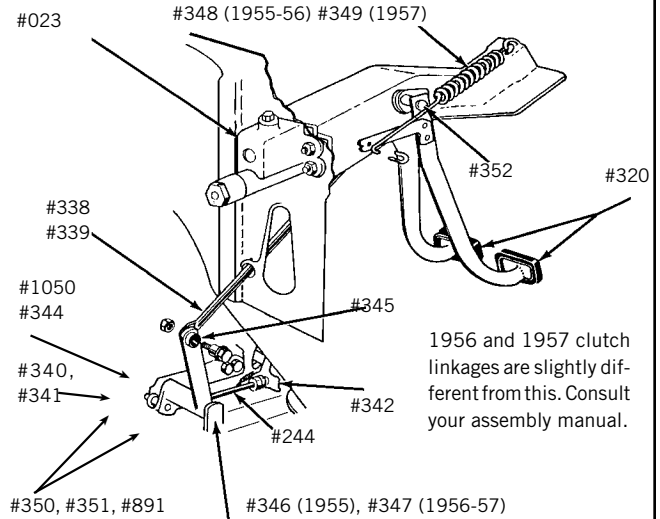

CLUTCH PEDAL CROSS SHAFT SLEEVE

This part is the sleeve which fits through the brake/clutch pedal housing.

1955-57 #16983.....\$15.95/ea.



CLUTCH PEDAL REBOUND BRACKET AND STOPPER

1955-56 #12577.....\$9.95/kit



CLUTCH PEDAL SPLINED OUTPUT ARM

1955-57 #12578.....\$15.95/kit



HEAVY DUTY CLUTCH PEDAL SHAFT

This heavy duty clutch pedal splined shaft replaces your original and really beefs up your clutch pedal. No more stripped splines.

1955-57 Splined Shaft..... #19300..... \$39.95/ea.



HEAVY DUTY CLUTCH PEDAL OUTPUT ARM

This is a heavy duty improved version of our #12578.

1955-57 Splined Lever #19301..... \$17.95/ea.



CLUTCH ROD KIT

Another great part from Danchuk. We made sure these parts were not only dimensionally correct but spared no expense on materials. The rod connects the clutch arm to the cross shaft. **Technical Note:** This kit and the clutch fork, part #342, on page 526, work together to replace early 1955 threaded clutch rods.

1955-57 #244..... \$23.95/kit



CLUTCH FRAME BRACKETS WITH PIVOT STUDS

1955..... #346..... \$18.95/ea.

1956-57 #347..... \$18.95/ea.



CLUTCH PEDAL RODS

Exact reproductions of the originals.

1955-56 #338..... \$13.95/ea.

1957..... #339..... \$13.95/ea.

BRAKE AND CLUTCH PEDAL BUMPER



This is a reproduction of the original for 1955 and 1956 models; it's an excellent functional replacement for the 1957.

Made in the USA.

1955-57 #818..... \$4.95/ea.



CLUTCH RELEASE BEARING

1955-57 #006..... \$62.95/ea.

#344

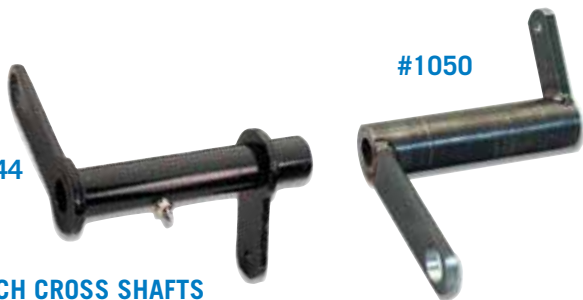

#1050

CLUTCH CROSS SHAFTS

Exact reproductions of the originals.

1955..... #1050..... \$33.95/ea.

1956-57 #344..... \$28.95/ea.

CLUTCH CROSS SHAFT BUSHING KIT



Everything about our clutch cross shaft bushing is custom. The bolt is turned from raw stock, case-hardened and plated with black oxide to protect it from rust. We've specified a bright plated, corrosion-resistant lock nut that features a nylon insert to hold it in place. The heart of the bushing kit are the two bushings, custom-made of Delrin, a high-tech material designed to provide smoother movement and greater durability.

Made in the USA.

1955-57 #345..... \$16.95/kit



CLUTCH CROSS SHAFT FELT WASHER



These install at either end of the clutch cross shaft to help keep dirt out and grease in around the pivot studs. Two are needed per car. **Made in the USA.**

1955-57 #891..... \$2.95/ea.



FELT FLOOR SEAL

This installs inside the car under the steering column seal between it and the firewall seal. The clutch pedal rod goes thru this.

1955-57 Standard Transmission... #867..... \$6.95/ea.





LOWER BELL HOUSING COVER

1955-59 Standard, V8 #14951 \$39.95/ea.



CLUTCH BELL HOUSING BRACKETS WITH PIVOT STUDS

1955..... #340..... \$26.95/ea.

1956-57 (Shown) #341 \$26.95/ea.



CLUTCH PIVOT STUDS

1955..... #350..... \$16.95/ea.

1956-57 #351..... \$16.95/ea.



ANTI-RATTLE CLUTCH LINKAGE SPRING

1955-57 #12331 \$1.50/ea.



FLYWHEEL DUST COVER

This triple chrome plated flywheel dust cover will add the finishing touch to your engine/transmission installation. Some trimming may be necessary when using large starters.

All TH350/400 w/ 2-7/8" Starter Slot

..... #2277 \$23.95/ea.



CLUTCH FORK

Made from the original GM tooling these are an exact reproduction of the originals. A Danchuk exclusive.

1955-57 & '55-62 Vette #342..... \$74.95/ea.

ADJUSTABLE GM BELL HOUSING CLUTCH FORK PIVOT



This adjustable pivot ball allows you to adjust the clutch fork/throwout bearing assembly for proper alignment. Adjusts from a minimum of 1-5/16-inch to a maximum of 1-11/16-inch. Bell-housing side threads are 13/16-inch x 16. Equivalent to GM 5503855.



All..... #19463..... \$19.95/ea.

CLUTCH BELL HOUSING BOOTS

Beautiful reproduction of the leather bell housing boots with retainer for the 55-57's.



1955-56 #197A..... \$21.95/ea.

1957..... #197..... \$21.95/ea.

#349



#348

CLUTCH PEDAL RETURN SPRINGS AND HANGERS



These complete kits are made with high-quality spring steel, manufactured to duplicate angles and dimensions of the original part. **Made in the USA***.

1955-56 Best..... #348* \$31.95/set

1955-56 Good..... #16772..... \$15.95/set

1957..... #349* \$31.95/set



DELUXE CLUTCH PEDAL UPGRADE KITS

The clutch pedal upgrade kit is the cure for stripped clutch pedal shaft to actuator arm problems, common to original equipment. The partially splined shaft in the pedal U-clamped arm is replaced with a fully splined shaft and a heavy-duty splined indexable arm. The kit includes clutch pedal with shaft installed, a redesigned clutch return spring bracket, weld on spring anchor tab, return spring, 4130 chrome moly push rod with heim joints, reworked cross shaft, lower linkage, clutch fork, pivot brackets, felt washers and all necessary bushings and grade 8 hardware.

1955-56	#15899	\$599.95/kit
1957	#15899A	\$599.95/kit



OE CLUTCH PEDAL KITS

Contains everything but the clutch pedal pad (part #320 on page 152). With this kit your linkage is almost 100% new!

1955-56	#1180	\$94.95/kit
1957 (Shown)	#1181	\$94.95/kit



BASIC CLUTCH PEDAL UPGRADE KITS

Includes pedal and arm only.

1955-56	#15900	\$245.95/kit
1957 (Shown)	#15900A	\$245.95/kit

LOKAR FLOOR MOUNT SHIFTERS

The exclusive floor mount brackets allow for installation above or below the floor on the transmission tunnel. Kits include splined shift arms with three optional offset arms for mounting to right or left. Removal of the transmission is not necessary. Floor mount shifter is equipped with the expected safety features of a Lokar shifter. Requires the use of rectangular shifter boots.

- All TH350, 12" #18394..... \$259.95/ea.
- All TH400, 12" #18395..... \$259.95/ea.
- All 700R4, 12" #18396..... \$259.95/ea.
- All 200-4R, 12" #18397..... \$259.95/ea.
- All 4L60, 12" #18398..... \$259.95/ea.
- All 4L60E, 12" #18399..... \$259.95/ea.
- All 4L80E, 12" #18400..... \$259.95/ea.



LOKAR LED BOOT INDICATOR WITH SENSOR KITS

Lokar's cable operated LED shift indicator sensor is designed for the flexibility to mount it in a variety of locations under the hood such as on the transmission, attached to the frame rail, to the floor pan, on the firewall or on the inner fender well. Remote mounting kit available for those out of the way, distant locations inside the vehicle, such as under the dash, behind the seat or in the trunk. Note: Round boot kits don't clear Lokar's floor mount shifters.

- All TH350/400, Round #16848..... \$283.95/kit
- All 700R4 & 200-4R, Round..... #16849..... \$283.95/kit
- All TH350/400, Rectangular..... #16850..... \$294.95/kit
- All 700R4 & 200-4R, Rectangular #16851..... \$294.95/kit

LOKAR FLOOR MOUNT SHIFTERS, BENCH BEND WITH KNOBS

The exclusive floor mount brackets allow for installation above or below the floor on the transmission tunnel. Kit includes splined shift arm with three optional offset arms for mounting to right or left. Removal of the transmission is not necessary. The Bench Bend shifter arm is designed to help clear the factory bench seats.

- All TH350, 16" #16841..... \$308.95/ea.
- All TH400, 16" #16842..... \$308.95/ea.
- All 700R4, 16" #16843..... \$308.95/ea.
- All 4L60, 16" #16844..... \$308.95/ea.
- All 200-4R, 16" #16845..... \$308.95/ea.
- All 4L60E, 16" #17402..... \$308.95/ea.

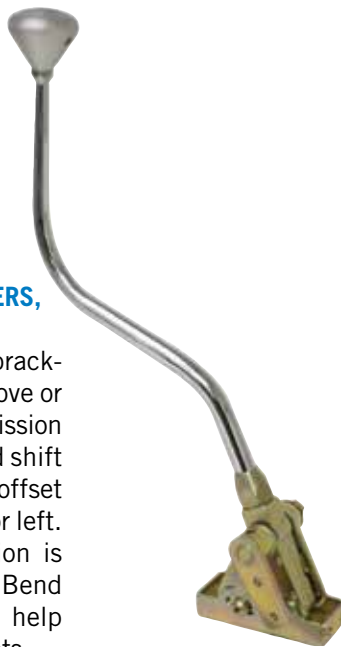

LOKAR MUSCLE CAR SHIFT KNOB ADAPTERS

Enjoy the look and feel of a classic Muscle Car Shifter on your Lokar shifter by installing this muscle car shift knob adapter. This shifter will give you the same "pull up to shift" tactile feel as the early Corvette but engineered for your updated Lokar shifter. Kit includes a shifter knob and installation instructions.

- All Black #18725..... \$76.95/ea.
- All Bright..... #18726..... \$76.95/ea.
- All White..... #18727..... \$76.95/ea.



LOKAR SHIFTER BOOTS WITH BILLET RINGS

Lokar boot kits include a rectangular or round billet ring with a ball milled edge, stainless screws and a black naugahyde boot. Note: Round boot kits do not clear Lokar's floor mount shifters.

- All Rectangular w/ Black Boot #16852..... \$77.95/ea.
- All Round w/ Black Boot..... #16853..... \$68.95/ea.



LOKAR DELUXE TOP SHIFTER BOOTS WITH SLIDING BEZELS

With Lokar's deluxe top rectangular boots with O-Ring sliding boot bezels, the boot can be placed anywhere along the length of the shifter lever allowing a portion of the lever to be exposed. O-ring sliding boot bezels are available separately to upgrade your existing shifter boot.

- All 5/8", Rectangular Boot w/ Aluminum Bezel #18388..... \$31.95/ea.
- All 5/8", Rectangular Boot w/ Chrome Bezel #18389..... \$36.95/ea.
- All 5/8", Rectangular Boot w/ Black Bezel #18390..... \$31.95/ea.
- All 5/8", Round Boot w/ Aluminum Bezel #18391..... \$31.95/ea.
- All 5/8", Round Boot w/ Chrome Bezel #18392..... \$36.95/ea.
- All 5/8", Round Boot w/ Black Bezel #18393..... \$31.95/ea.



LOKAR 2-INCH SHIFT KNOBS

Plain button shifter knobs are for use on Lokar shifters. Others are universal. 3/8-24 Thread.

- All Round, Satin..... #17511..... \$36.95/ea.
- All Round, Black..... #17512..... \$36.95/ea.
- All Venetian Polished..... #17516..... \$50.95/ea.
- All Round, Satin, Plain Button..... #17517..... \$39.95/ea.
- All Round, Black, Plain Button..... #17518..... \$39.95/ea.
- All Round Polished, Plain Button... #17519..... \$52.95/ea.
- All Round, Polished..... #17513..... \$50.95/ea.
- All Venetian Satin #17514..... \$36.95/ea.
- All Venetian Black #17515..... \$36.95/ea.
- All Venetian Satin, Plain Button #17520..... \$39.95/ea.
- All Venetian Black, Plain Button ... #17521..... \$39.95/ea.
- All Venetian Polished, Plain Button #17522..... \$52.95/ea.
- All Deco, Satin, Plain Button..... #17523..... \$39.95/ea.
- All Deco, Black, Plain Button..... #17524..... \$39.95/ea.
- All Deco, Polished, Plain Button ... #17525..... \$52.95/ea.



LOKAR SLIDING BEZELS

- All 5/8", Aluminum #18385..... \$18.95/ea.
- All 5/8", Chrome..... #18386..... \$23.95/ea.
- All 5/8", Black #18387..... \$18.95/ea.

LOKAR SHIFTER KNOB ADAPTERS

While personal style is important, at Lokar, "safety is never an extravagance". To fill the void between personal preference and personal safety, Lokar developed a shifter knob adapter which allows you to express yourself with highly custom knobs, yet still retain all of the safety features and benefits of a Lokar Shifter, including the positive lock-out in park and neutral. The adapter is offered with common 3/8-16 or 3/8-24 thread sizes.



- All 3/8-16 Knob #16846 \$35.95/ea.
- All 3/8-24 Knob #16847 \$35.95/ea.

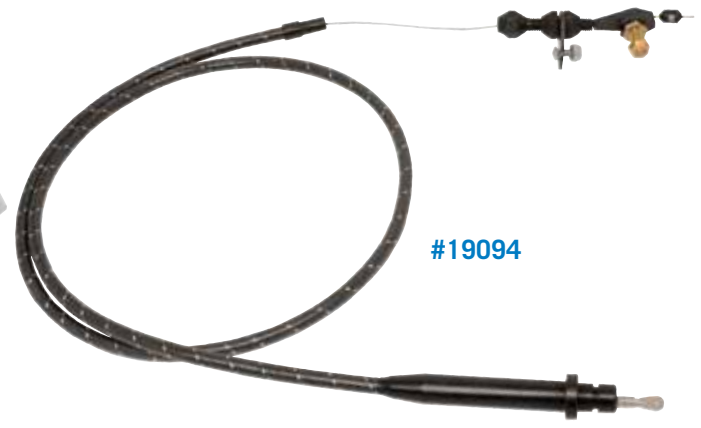

#19094

LOKAR VINTAGE SERIES THROTTLE CABLES

- All Black/White, 24" #19085 \$67.95/ea.
- All Black/Blue, 24" #19086 \$67.95/ea.
- All Black/Red, 24" #19087 \$67.95/ea.
- All Black/White, 36" #19088 \$76.95/ea.
- All Black/Blue, 36" #19089 \$76.95/ea.
- All Black/Red, 36" #19090 \$76.95/ea.
- All Black/White, 36", LS1 #19091 \$76.95/ea.
- All Black/Blue, 36", LS1 #19092 \$76.95/ea.
- All Black/Red, 36", LS1 #19093 \$76.95/ea.



THROTTLE/VALVE/UNIVERSAL CABLE

- All 700R4 & 200-4R #16969 \$64.95/ea.



OVERDRIVE WIRE HARNESS SWITCH PLUG

This new overdrive connector plug holds the four wires that plug onto the kick down switch on the carburetor.

- 1955-68 #18935 \$21.95/ea.



#16970



#16971



#16972



#16973

THROTTLE/VALVE CABLE BRACKETS

TV brackets for the 700R4 and 200-4R. All are carb mount except #16970, which is a manifold mount.

- All Holley Carb/Manifold Mount #16970 \$31.95/ea.
- All QuadraJet Carb #16972 \$39.95/ea.
- All Holley Carb #16971 \$41.95/ea.
- All Edelbrock Carb #16973 \$54.95/ea.

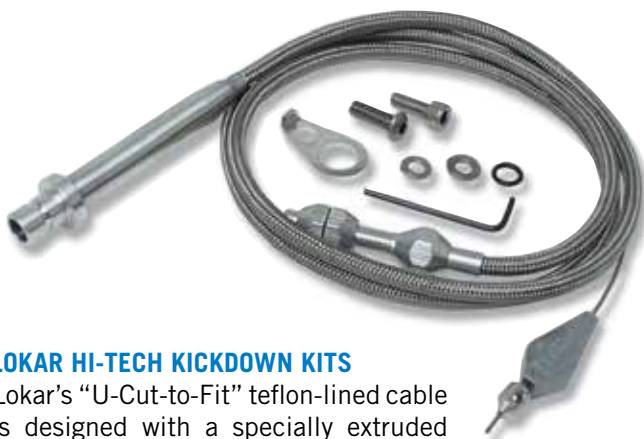

LOKAR HI-TECH KICKDOWN KITS

Lokar's "U-Cut-to-Fit" teflon-lined cable is designed with a specially extruded liner for extended life of the cable. Kick-down features aluminum fittings with ferrule to eliminate frayed cable ends. Kickdowns are adaptable for all types of manifolds. Mount the kickdown with the stainless steel carburetor bracket and return springs. Complete instructions included in the kit.

- All TH350, Braided Stainless..... #12025.....\$109.95/kit
- All TH350 Tuned Port, Braided Stainless
..... #12026.....\$109.95/kit
- All 700R4, Braided Stainless..... #12028.....\$109.95/kit
- All 700R4 Tuned Port, Braided Stainless
..... #12029.....\$109.95/kit
- All 200-4R, Braided Stainless #14154.....\$99.95/kit
- All TH350, Black #16281.....\$105.95/ea.
- All 700R4, Black #16282.....\$105.95/ea.
- All 200-4R, Black #16283.....\$105.95/ea.

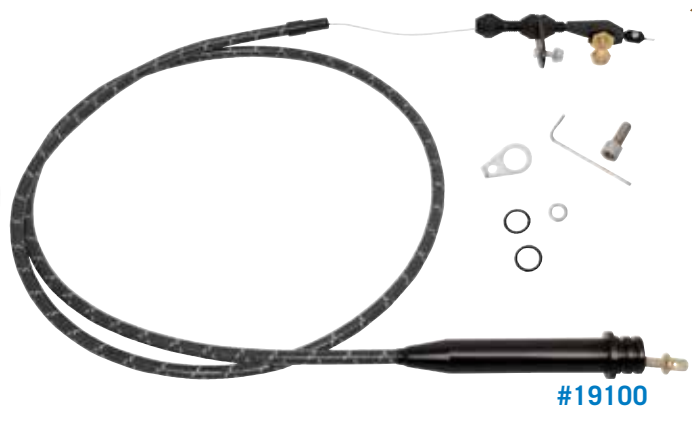

#19100

LOKAR VINTAGE SERIES KICKDOWN CABLES

- All Black/White, TH350..... #19094..... \$104.95/ea.
- All Black/Blue, TH350..... #19095..... \$104.95/ea.
- All Black/Red, TH350..... #19096..... \$104.95/ea.
- All Black/White, TH400..... #19097..... \$116.95/ea.
- All Black/Blue, TH400..... #19098..... \$116.95/ea.
- All Black/Red, TH400..... #19133..... \$116.95/ea.
- All Black/White, 700R4..... #19099..... \$104.95/ea.
- All Black/Blue, 700R4..... #19100..... \$104.95/ea.
- All Black/Red, 700R4..... #19101..... \$104.95/ea.



LOKAR ELECTRIC KICKDOWN KIT

Lokar's TH400 electric kickdown is cable operated. Electric switch is housed in a billet aluminum box that mounts with the transmission pan bolts. This design eliminates mounting unsightly electrical switches on the carburetor, manifold or near the gas pedal.

- All..... #12027.....\$106.95/kit



OVERDRIVE KICKDOWN BRACKETS

This bracket attaches to the carburetor and holds the overdrive kick down switch. The actuator attaches to the throttle lever. Use with Carter WCFB # 2218S 4-bbl carburetor..

- 1955 2218S..... #18936.....\$124.95/pr.



KICKDOWN CONNECTOR

Molded connector for TH400 GM transmission kickdown which is located on the side of the transmission.

- All TH400..... #12348..... \$13.95/ea.



TRANSMISSION KICKDOWN STUD

- 1986 & Up TH350 #13354..... \$6.95/ea.



LOKAR STAINLESS KICKDOWN BRACKET AND CABLE

Standard adjustable GM detent with Lokar's stainless mounting bracket mounts onto the two back manifold bolts. Designed for 4-barrel-type carburetors for small block Chevs. Kit includes extender for more versatility in adjusting cable length where needed.

All TH350..... #12024..... \$56.95/ea.

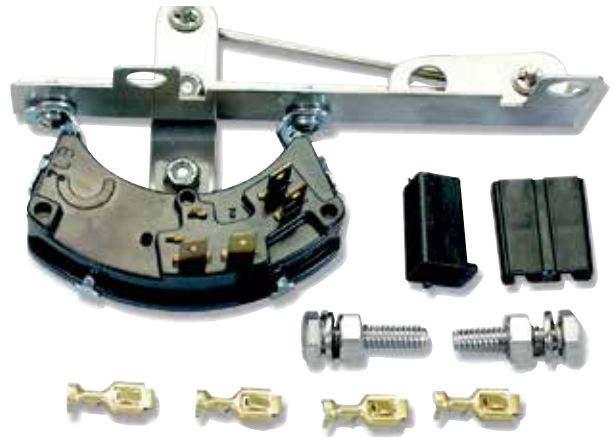

NEUTRAL SAFETY/BACK-UP LIGHT SWITCH ASSEMBLIES

These complete assemblies are for use on the TH350 and 400 transmissions. All necessary mounting hardware and connectors are included.

1955-57 TH350 #1345..... \$115.95/ea.

1955-57 TH400 (Shown) #1346..... \$115.95/ea.

STAINLESS KICKDOWN BRACKET

This mounts on the driver side of the engine on the two rear intake manifold bolts.

All TH350..... #11268..... \$28.95/ea.



THROTTLE/KICKDOWN CABLE BRACKETS

This bracket, when used with Lokar throttle cables, will allow the Ramjet 350 to work properly in any vehicle. When using this bracket with an automatic transmission be sure to order the correct transmission specific Lokar kickdown cable.

All Stainless, TH350 Ramjet..... #13015..... \$75.95/ea.



TRANSMISSION KICKDOWN LEVER ASSEMBLY

1955-56 Middle, V8 #15440..... \$29.95/ea.



NEUTRAL SAFETY BACK-UP LIGHT SWITCHES

Without this important part, your car won't start. Part #035 will also work for TH350/400, 200-4R and 700R4 applications on 57 columns as a bolt in and on 55-56 columns with minor modification.

1955-56 Powerglide..... #1104..... \$26.95/ea.

1957 Powerglide..... #1105..... \$26.95/ea.

1957 Turboglide (Fits '64-'66)..... #035..... \$17.95/ea.



NEUTRAL SAFETY OR BACK-UP LIGHT SWITCH KIT

This kit offers the choice of back-up light switch or neutral safety switch kit. Kit fits TH350, TH400, TH700R4, TH2004R, 4L60, 4L60E and 4L80E transmissions. Single trigger for back-up light switch, or double trigger for neutral safety switch. KIT NOT INTENDED TO FUNCTION AS BOTH. All mounting hardware included. Works with Lokar and may work with others.

All Auto..... #15880..... \$41.95/kit