

2. Lenses & Lights

SECTION AT A GLANCE:

Taillights.....	62
Related	64
Third Brake Light.....	68
Headlights & Related	69-74
Reflectors	75
Parklights	76
Back-Up Lights	78
Lens Gaskets.....	79
Dome Lights.....	80
License Lights.....	81
Light Bulbs	82
Indicator Lenses.....	83
Dash Lenses.....	84

TAILLIGHTS

1955 TAILLIGHT HOUSING ASSEMBLY



Our 1955 taillight bezels and lenses have always been the best in the industry, but with the addition of the housings we can offer the complete assembly. The taillight assemblies come with everything you need to completely refresh and beautify the taillights on your project. Danchuk #15512 will work on any 1955 classic Chevy. Proudly **Made in the USA***.



1955 Complete Assembly	#15512*	\$269.95/pr.
1955 Best, Bezel Only	#153*	\$99.95/pr.
1955 Good, Bezel Only	#16737	\$69.95/pr.



1955 TAILLIGHT HOUSING



Two needed per car.

1955	#14632	\$49.95/ea.
-------------------	---------------------	--------------------

1956 LOWER TAILLIGHT CURVED J-NUTS

These install at the bottom of the taillight opening the bottom center screw goes through the bezel and screws into the clip.



1956	#16629	\$9.95/pr.
-------------------	---------------------	-------------------



1956 UNDER TAILLIGHT REFLECTORS



A perfectly detailed mould makes the brilliant red lenses and a precision stamping die does the rest, out of beautiful and indestructible stainless steel. The engraving is exact, you can't tell the difference from the originals. **Made in the USA***.

1956 Best	#499*	\$25.95/pr.
1956 Good	#16742	\$18.95/pr.

1956 TAILLIGHT REFLECTOR LED KIT

Not your standard 1956 taillight reflector. This replacement 1956 taillight reflector adds the custom touch and safety of five bright LED lamps to brighten up the rear of your classic. The LED lights are easily wired into your existing wiring harness and improve visibility without changing the original classic design.



1956	#16276	\$9.95/ea.
-------------------	---------------------	-------------------

1956 TAILLIGHT HOUSING ASSEMBLY 

We've gone over the top with this one by starting with a perfect set of originals and making all the tooling **in the United States of America**. We copied every curve and contour to make six different molds for all the castings. Then we made numerous stamping dies for the bulb sockets, gas door parts and even the original style clip that safely holds the wiring in place. After all parts look and fit together perfect, we send them out to get the best quality chrome plating money can buy. The end result is a set of taillight housings that are absolutely breath taking. We also include all mounting hardware, reflectors, seals, gaskets and a pair each of our spectacular red taillight lenses and clear back-up light lenses.



#1045LK



#1045RK



1956.....	#1045.....	\$579.95/set
1956 Taillight Mounting Kit.....	#1045A.....	\$10.95/kit
1956 Taillight Housing Wire Clip.....	#1045B.....	\$2.95/ea.
1956 Taillight Knob, Driver	#1045LK.....	\$49.95/ea.
1956 Taillight Knob, Passenger.....	#1045RK.....	\$29.95/ea.



1957 TAILLIGHT HOUSING ASSEMBLY 

Since 1957 these beautiful taillights have brilliantly lit up the rear of our classics. And we couldn't be happier with the results of our American made tooling on these show stopping pieces. They fit exactly like originals and do we dare say, look better? We put hours into hand working each casting before the chrome process even begins. After each casting is prepped then we put the best show quality chrome money can buy and then finish them off with correctly pressed in light bulb sockets, bulbs, gaskets, studs, screws, seals and the most gorgeous Danchuk made red lenses there are. **"Danchuk, There's No Comparison"**. Part #16757 is HOUSING ONLY, so light bulb sockets, bulbs, gaskets, studs, screws, seals, and lenses are not included.



1957 Best	#965*	\$469.95/set
1957 Good, Housing Only.....	#16757.....	\$299.95/pr.

 **WARNING!** Products on these pages may contain chemicals known to the State Of California to cause cancer and/or birth defects or reproductive harm. www.p65warnings.ca.gov



#487



#491A



#495

TAILLIGHT RELATED

TAILLIGHT LENSES



Our lenses are manufactured under the most stringent standards. We use the highest quality plastics, which we guarantee against fading, cracking, or warping. You'll find our lenses fit like the originals you're replacing, and they may last even longer. Gaskets and hardware not included. See right for gaskets and page 76 for screw sets. **Made in the USA.**

1955.....	#487.....	\$12.95/pr.
1956.....	#491A.....	\$12.95/pr.
1957.....	#495.....	\$12.95/pr.

Note: Our 1955 lenses do not accommodate diffusers.



#12292



#10478

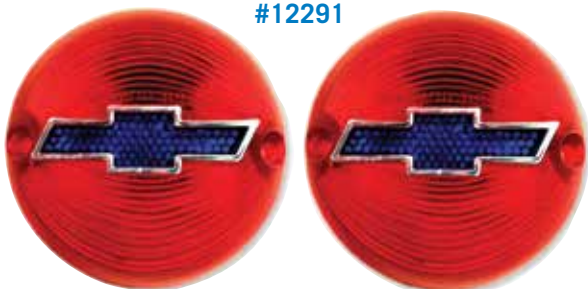

#12291



#10486

TAILLIGHT LENSES WITH BLUE DOT BOWTIE

Gaskets and hardware not included. Check local regulations before installing.

1955.....	#12290.....	\$40.95/pr.
1956.....	#12291.....	\$40.95/pr.
1957.....	#12292.....	\$40.95/pr.

TAILLIGHT LENSES WITH BOWTIE

Gaskets and hardware not included.

1955.....	#10478.....	\$34.95/pr.
1955 w/ Chrome Bowtie.....	#10479.....	\$34.95/pr.
1956.....	#10482.....	\$34.95/pr.
1956 w/ Chrome Bowtie.....	#10483.....	\$34.95/pr.
1957.....	#10486.....	\$34.95/pr.
1957 w/ Chrome Bowtie.....	#10487.....	\$34.95/pr.

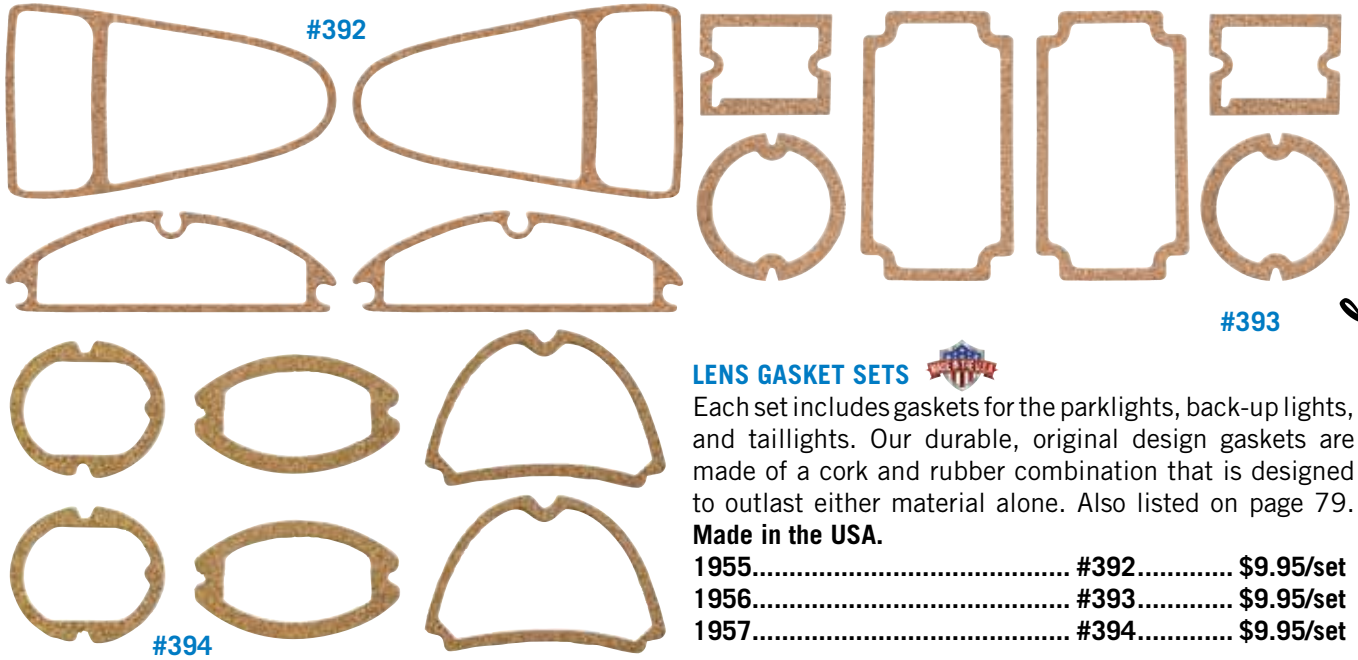

LENS GASKET SETS

Each set includes gaskets for the parklights, back-up lights, and taillights. Our durable, original design gaskets are made of a cork and rubber combination that is designed to outlast either material alone. Also listed on page 79. **Made in the USA.**

1955.....	#392.....	\$9.95/set
1956.....	#393.....	\$9.95/set
1957.....	#394.....	\$9.95/set



CUSTOM TAILLIGHT LENSES

If it is the high-tech modern look your striving for with your classic Chevy, then these custom lenses are exactly what you need. Installation requires gluing the lenses to the bezels. The 1956 version will require modifying the housing to clear the lens.

1955.....	#2631.....	\$63.95/pr.
1956.....	#2632.....	\$63.95/pr.



1957 SEQUENTIAL LED TAILLIGHT LENS

These 32-LED sequential taillight lens assemblies install easily with the attached connector that plugs into your existing taillight socket. These feature fully sealed electronics and super bright LED lights that come on starting on towards the center and move to the outside until the entire taillight is illuminated. Includes a selector switch to turn the sequential function off, make the LED's light left to right or right to left. Also features a brake attention option with a sequential-once function.

1957.....	#19448.....	\$41.95/ea.
-----------	-------------	-------------



TAILLIGHT RELATED



#17191



#17192

HOUSINGS NOT INCLUDED



#17193

DIGI-TAILS CONVERSION KITS

DIGI-TAILS kits are safer and brighter than standard factory lights or other LED kits because these light-panels contain high-intensity wide-angled LEDs that are strategically positioned to maximize light output and fully optimize your lenses. These are also the only fully sequential LED kits. DIGI-TAILS utilize advanced technology by lighting LED's in a fluid and sweeping pattern, rather than merely lighting up blocks of LED's. DIGI-TAILS allows you to choose standard operations or the fully sequential feature with a flip of a switch, conveniently located on every board. Due to the LED's low resistance a new electronic flasher, part #13677, is recommended. Included pigtail kits come complete with everything needed to replace your old standard bulbs with high quality LED lighting; clear instructions are included.

1955 Taillight.....	#17191.....	\$249.95/kit
1956 Taillight.....	#17192.....	\$189.95/kit
1957 Taillight.....	#17193.....	\$199.95/kit
1955 Parklight.....	#17194.....	\$115.95/kit
1956 Parklight.....	#17195.....	\$115.95/kit
1957 Parklight.....	#17196.....	\$105.95/kit
1955 Taillight, Parklight.....	#17197.....	\$329.95/kit
1956 Taillight, Parklight.....	#17198.....	\$259.95/kit
1957 Taillight, Parklight.....	#17199.....	\$249.95/kit

LED LENS ASSEMBLIES

These LED taillights and back-up lights feature fully sealed electronics and come with #1157 or #1156 plug for easy installation (except '56 version). Taillights are available in either red or clear lenses. Due to the LED's low resistance a new electronic flasher, part #13677, at right, is recommended.



#14540



LED FLASHER

This low resistance flasher will work with both LED and incandescent bulbs and is a must have when using LED light bulbs.

All Flasher, LED..... #13677 \$21.95/ea.

1955 Taillight, w/ Red Lens.....	#14540.....	\$36.95/ea.
1955 Back-Up, w/ Clear Lens.....	#14542.....	\$42.95/ea.
1956 Taillight, w/ Red Lens.....	#14543.....	\$28.95/ea.
1957 Taillight, w/ Red Lens.....	#14546.....	\$32.95/ea.



BLUE DOTS WITH BOWTIE EMBLEMS

All..... #1923..... \$19.95/pr.

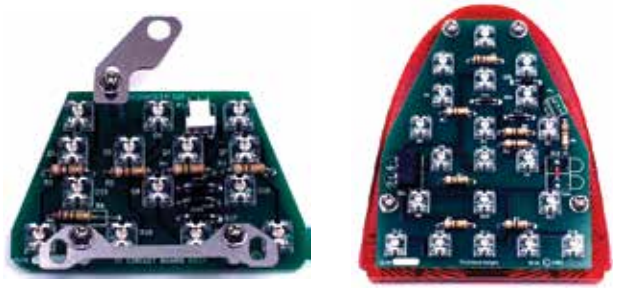

TAILLIGHT LED CONVERSIONS

LED taillight conversions convert the tail, stop, and turn signals into very bright and visible LED's giving you maximum brightness for better visibility and safety. They don't run hot like traditional bulbs so your lenses last longer too. Due to the LED's low resistance a new electronic flasher, part #13677, on page 66, is recommended.

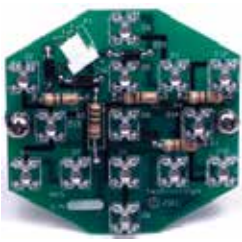

1955.....	#12293.....	\$89.95/pr.
1956.....	#12295.....	\$89.95/pr.
1957.....	#12296.....	\$89.95/pr.



1957 TAILLIGHT DUST SHIELDS

Keep the dust and gunk out with these top notch reproductions. Part #1002 comes complete and ready to use with the retainers. Part #564 is rubber only. For use with #551 back body-to-bumper seal, found on page 54.

Made in the USA.

w/ Retainers	#1002.....	\$25.95/pr.
w/o Retainers	#564.....	\$13.95/pr.



TAILLIGHT HARNESS PIGTAILS

1955-56	#12246.....	\$38.95/pr.
1957.....	#12247.....	\$38.95/pr.

TAILLIGHT HARNESS PIGTAIL GROMMETS

1955-56	#12244.....	\$27.95/pr.
1957.....	#12245.....	\$27.95/pr.

1956 TAILLIGHT HOUSING WIRE CLIP

1956.....	#1045B.....	\$2.95/ea.
-----------	-------------	------------



1956 UNDER TAILLIGHT GASKETS

For use with the back body-to-bumper seal, part #550, found on page 54. **Made in the USA.**

1956.....	#920.....	\$9.95/pr.
-----------	-----------	------------

1957 TAILLIGHT HOUSING-TO-BODY SEALS



These seals install between the taillight housing and body to block out moisture and dirt. Included in our part #965.

Made in the USA*.



1957 Best	#032*	\$9.95/pr.
1957 Good	#16758.....	\$3.95/pr.

1955 TAILLIGHT MOUNTING STRAPS



These stainless steel straps divide the back-up light lens from the taillight lens. **Made in the USA.**



1955.....	#073*	\$17.95/pr.
-----------	-------------	-------------

TAILLIGHT MOUNTING ASSEMBLIES

All the assorted screws and retainer clips to do the job right. Fasten those new taillight lenses, mounting straps, and bezels in place the right way. Part #16629 is included in the #1045A. **Made in the USA.**



1955.....	#1029.....	\$9.95/set
1956.....	#1045A.....	\$10.95/set
1956 Lower J-Nuts.....	#16629.....	\$9.95/pr.

WARNING! Products on these pages may contain chemicals known to the State Of California to cause cancer and/or birth defects or reproductive harm. www.p65warnings.ca.gov



#560



#560A

INNER PARKLIGHT AND TAILLIGHT HOUSING SEALS

These seals install between the parklight and taillight housings and body to block out moisture and dirt. **Made in the USA***.

1955.....	#560*	\$12.95/set
1956 Best.....	#560A*	\$12.95/set
1956 Good.....	#16778	\$7.95/set



TAILLIGHT AND HEADLIGHT ASSEMBLY SEALS

These install in the provided channel in the taillight and headlight bezels and seal the bezel to the fender.

Made in the USA.

1956 Taillight, '57 Headlight.....	#557.....	\$12.95/pr.
------------------------------------	-----------	-------------



LED BRAKE LIGHT ATTENTION MODULE

The LED brake light attention module rapidly flashes the third brake light or both taillights for a second or two to gain the attention of the driver behind you. Flash duration and speed are adjustable. Use only with LED taillights.

All.....	#16825.....	\$14.95/ea.
----------	-------------	-------------



#12241



#13202

TRUNK THIRD BRAKE LIGHT ASSEMBLIES

Designed to replace the rear '55 trunk emblem or the rear '57 vees, these third brake light assemblies are a stylish addition to any classic. The 55 unit comes with a beautifully chrome plated bezel that surrounds a red lens which includes a raised chrome bow-tie accent. Bright LED lights signal to those behind you that you are stopping and behind the bow-tie is an LED running light. The 57 units are available in either a gold tone or chrome with two top quality lenses back by LED lights that glow when the brake pedal is depressed. The 57 unit is designed to fit as original without mounting back piece or it can be mounted on any flat surface. Each assembly comes with complete instructions. Danchuk #12242 wiring harness required for installation.

1955 Chrome w/ Bowtie.....	#12241.....	\$234.95/ea.
1957 Gold.....	#13201.....	\$269.95/ea.
1957 Chrome.....	#13202.....	\$234.95/ea.



THIRD BRAKE LIGHT HARNESS

For use with part #13201, #13202 and #12241.

1955-57.....	#12242.....	\$25.95/ea.
--------------	-------------	-------------



BILLET BOWTIE PEDESTAL THIRD BRAKE LIGHTS

All Polished.....	#10029.....	\$87.95/ea.
All Brushed.....	#10028.....	\$74.95/ea.



#12638



#12639



#12640

HEADLIGHT BUCKETS

Manufactured according to the original Chevrolet specs from top quality steel these headlight buckets are perfect to replace your rusted originals. Sold as a pair, they come complete with the bezel clips and bulb adjusters installed. If you need sealed beam buckets, see our bucket assemblies below.

1955.....	#12638.....	\$99.95/pr.
1956.....	#12639.....	\$99.95/pr.
1957.....	#12640.....	\$99.95/pr.



#16127



#16987



HEADLIGHT BUCKET TO FENDER SEALS



These seal the rear lip of the headlight bucket to the fender to keep dirt and moisture out. **Made in the USA***

1955-57 Best.....	#865*	\$10.95/pr.
1955-57 Good.....	#16719.....	\$5.95/pr.

HEADLIGHT BUCKET ASSEMBLIES

These come complete with the headlight bucket, sealed beam bucket, retaining ring, springs, gasket and adjuster. All you need to add is the bulb and a new bezel. Wiring is sold separately. Fits both sides. Two required per car.

1955.....	#16127.....	\$49.95/ea.
1957.....	#16987.....	\$52.95/ea.

HEADLIGHT BUCKET WIRE GROMMETS

The headlight wire runs through these grommets which are installed at the rear of the headlight bucket to protect the wire from chafing on the metal housing.



1955-56 Best (Shown).....	#835.....	\$5.95/pr.
1955-56 Good.....	#16718.....	\$3.95/pr.



HEADLIGHT BUCKET TO BODY FASTENERS

1955-57	#12337.....	\$4.50/set
---------------	-------------	------------

WARNING! Products on these pages may contain chemicals known to the State Of California to cause cancer and/or birth defects or reproductive harm. www.p65warnings.ca.gov

1955 HEADLIGHT BEZELS



Produced in Santa Ana, California by our master toolmakers these bezels are a shining example of the quality and workmanship we put into all our parts. Finished in a show quality copper-buffed chrome, these bezels fit and look exactly like GM originals. Rubber seals and hardware included in part #593. **Made in the USA***.



- 1955 Best #593* \$139.95/pr.
- 1955 Good - Hardware not included #17684 \$79.95/pr.

1956 HEADLIGHT BEZELS



Just like our 1955 versions, these are produced in Santa Ana, California by our master toolmakers these bezels are a shining example of the quality and workmanship we put into all our parts. Finished in a show quality copper-buffed chrome, these bezels fit and look exactly like GM originals. Rubber seals and hardware included in part #1057. **Made in the USA***.



- 1956 Best #1057* \$129.95/pr.
- 1956 Good - Hardware not included #17685 \$99.95/pr.

1957 HEADLIGHT BEZEL ASSEMBLIES



Danchuk's '57 bezels are far superior to any other bezels on the market. Our attention to detail shows in the highly polished surfaces, black painted air intakes and beautiful show quality chrome plating. Rubber seals and mounting hardware included in part #877. **Made in the USA***.



- 1957 Best #877* \$269.95/pr.
- 1957 Good - Hardware not included #17686 \$196.95/pr.



STAINLESS HEADLIGHT RETAINING RINGS



These rings are a beautiful final touch to top off the sparkle of your front end. These exact reproductions are made by Danchuk from top quality stainless steel correctly formed to original specifications.

- 1955 #16030 \$22.95/ea.
- 1956-57 (Shown) #14222 \$22.95/ea.



1957 HEADLIGHT BEZEL INSERT DECALS 

For that clean, crisp look, detail your headlight bezels with our decals. One sheet of die-cut vinyl decals will detail both headlight housings. They are faster and easier to apply than paint. Matte black finish. **Made in the USA.**

1957..... #333..... \$10.95/set



REPLACEMENT SEALED BEAM HEADLIGHT

This is a replacement sealed beam headlight that installs without modifications. 7-inch high/low design.

1955-57 #128..... \$11.95/ea.



HEADLIGHT BEZEL SEALS 

We make these seals with the wire cores so they look and install exactly like they did when GM installed them originally. **Made in the USA.**

1955-56 #864..... \$10.95/pr.



HEADLIGHT BEZEL SCREW SETS 

Whether you're replacing the headlight bezels or just detailing the front end, installing new mounting hardware is the best way to get the glimmering results you want. One set per car required. **Made in the USA.**

1955..... #1743..... \$2.95/set
 1956..... #1744..... \$2.95/set
 1957..... #1745..... \$2.95/set



HEADLIGHT ADJUSTMENT SCREW SETS 

Each headlight requires two screws, one for vertical adjustment and one for horizontal. One set required per car.

1955-57 #1154..... \$2.95/set
 1955-57 #12233* \$16.95/set

*Note: Comes with nylon insert.

HEADLIGHT ADJUSTMENT SPRING

The headlight adjustment spring provides the tension necessary to properly adjust the headlight and keep it from moving. Two required per car.

1955-57 #1155..... \$2.95/ea.



HEADLIGHT LEGEND:

- DOT** Dept. of Transportation Approved
- EURO** Euro Style "Flat" Lens
- CLASSIC** OE Style Round Lens
- LED** Light Emitting Diode
- HID** High Intensity Discharge
- DRL** Daytime Running Light
- H4** Bulb Plug Type
- COB** Chip On Board (Type of LED)
- SMD** Surface Mount Diode (Type of LED)
- XENON** Halogen Bulb Enhanced with Xenon Gas

MORE HEADLIGHTS AVAILABLE ON NEXT PAGE

DELTA
DELTA 7" HALO HEADLIGHTS

These Delta Halo Headlights; DOT and Classic series are now available in Halo configuration. This 7.5 watt COB LED Angel Eye halo provides an element of safety as a DRL light as well as a stylish trend setting look to your classic vehicle, hot rod to present. Installation is as easy as a bulb replacement with one additional step of running your Halo power lead to your ignition fuse or other 12V ignition source. **Made in the USA.**

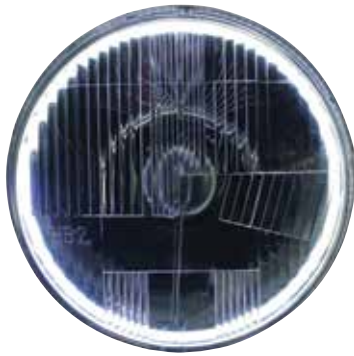

- All DOT w/ Euro, LED (Shown) #18357 \$459.95/pr.
- All Classic LED #18359 \$459.95/pr.
- All DOT w/ Euro, Xenon..... #18358 \$259.95/pr.
- All Classic Xenon #18360 \$259.95/pr.

CITY LIGHTS HEADLIGHTS WIRE HARNESS

This harness makes it easy for you to wire your Delta headlights by utilizing the "City Light" feature for daytime runner, parklight or turn signal options.

- 1955-57 #14831 \$49.95/ea.

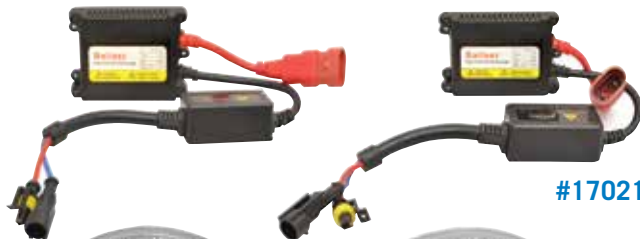

#17021



#17019

#14578



#17787

DELTA LED 7" HEADLIGHT KITS



7-inch LED Classic Series replacement for 2-Headlight System on Classic Cars and Hot Rods. Replaces 6014/H6024 Type High/Low beam. Powerful LED CREE® Technology combined with Delta Tech's Prismatic lens and flawless parabola delivers unmatched power, clarity and near daylight illumination at 1900 Lumen at both high and low beam, while drawing only two amps per light. This performance comes with expected life of 25,000 hours or 22 years. Assembled in the USA.

- All Classic..... #17785 \$369.95/kit
- All Classic w/ City Lights Kit..... #17786 \$389.95/kit
- All DOT..... #17787 \$379.95/kit
- All DOT w/ City Light Kit..... #17788 \$385.95/kit

DELTA

DELTA XENON AND H.I.D. HEADLIGHTS



Delta H4 and H.I.D. headlights are a direct replacement for your stock sealed beam lights and re-use the original mounting hardware and connectors. Delta headlights are available in bright white Xenon or High Intensity Discharge (H.I.D.). Lenses are available in two styles; classic curved lenses like the originals, or Euro that have a flat European style lens with a built-in city light that can be wired as a park/turn light or daytime runner. Note: to install Delta or H4 headlights minor trimming to sealed beam bucket is necessary. We recommend that when installing H4 type headlights that a relay kit such as #16826 be installed for better performance and to reduce the load on the headlight switch. H.I.D. headlights may not be DOT compliant, please check your local regulations for approval.

- 1955-57 7" Classic w/ Xenon Bulbs..#14646 .. \$139.95/kit
- 1955-57 7" Classic w/ HID Bulb#14577 .. \$287.95/kit
- 1955-57 7" Euro w/ Xenon Bulbs.....#14829 .. \$128.95/pr.
- 1955-57 7" Euro w/ Xenon Bulbs and City Lights#14647 .. \$138.95/pr.
- 1955-57 7" Euro Hi/Lo H.I.D. w/ City Lights#14830 .. \$399.95/kit
- 1955-57 7" Classic Hi/Lo Xenon w/ City Lights#17019 .. \$138.95/pr.
- 1955-57 7" Classic Hi/Lo H.I.D. w/ City Lights#17020 .. \$379.95/kit
- 1955-57 7" Euro Hi/Lo H.I.D.....#17021 .. \$342.95/kit
- All H4 Xenon Replacement Bulb, 60/55 Watt#14578 \$25.95/pr.



#19396



#19397

DAPPER LIGHTING OE7 LED HEADLIGHTS

The Dapper Lighting OE7 has their LED projector technology in a package that looks original, but with a clear lens. They deliver 3X more light than a traditional H4 conversions and they draw 65% less power than a sealed beam. Their patent pending Active Cooling System provides up to 30% cooler LED operating temperatures than other brands so your LED's will last longer. The OE7 also features Progressive Low/High output to aid your eyes when driving at night. When you turn on your hi-beams, your low beams dim so your eyes can adjust to seeing light further down the road and studies show the foreground light should be decreased to increase distance visibility.

- 1955-57 Clear Lens..... #19396..... \$299.95/pr.
- 1955-57 OE Lens..... #19397..... \$349.95/pr.



#19302



#19060



#17024



H4 HALOGEN LED HEADLIGHTS WITH WHITE HALO

These are 7-inch halogen replacement headlights with a white LED halo around the outer rim of the bulb. The COB and SMD halo rings are much brighter than the standard LED halos and can easily be seen during the day or night even with the headlights on. Minor trimming of light bucket is required on #17024.

- 1955-57 Crystal w/ White Standard Halo..... #17024..... \$49.95/pr.
- 1955-57 OE Style w/ White SMD Halo..... #19060..... \$99.95/pr.
- 1955-57 OE Style w/ White COB Halo..... #19302..... \$99.95/pr.



LED HALO HALOGEN HEADLIGHTS WITH SWITCHBACKS

Upgrade your headlights with these crystal reflector halogen headlights with Switchback LED Halos. The Switchback LED allows you to wire it as a DRL that turns from white to amber when signaling. Additional Halo wiring is required.

- All White DRL/Amber..... #19170..... \$149.95/pr.

CRYSTAL HEADLIGHT BULB WITH 10 AMBER LED AUX LIGHT

These 7-inch headlights feature a multi faceted aluminum reflector (not plastic like some others) and crystal glass lens and meets DOT/SAE Standards. The 10 Amber LEDs have many uses and can be wired for turn signal, DLR's, parklights, etc. Be sure to order part #16826 relay kit for best performance. Minor trimming of light bucket is required.



- All..... #16824..... \$41.95/ea.



STANDARD

SMD

COB



OE STYLE H4 HALOGEN HEADLIGHTS

- All OE Style..... #18864..... \$45.95/pr.

WARNING! Products on these pages may contain chemicals known to the State Of California to cause cancer and/or birth defects or reproductive harm. www.p65warnings.ca.gov

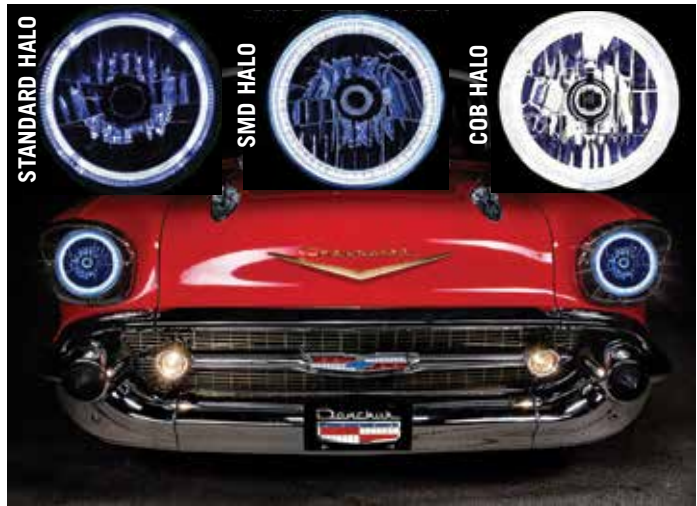

HEADLIGHT RELATED

HALOGEN HEADLIGHTS WITH LED HALO

These Halo headlights feature SMD LED in white or multi-colored and use an H4 halogen bulb that produces a brighter light than OE. The Halo lights can be wired as a daytime running light.

On part #17941, the wireless remote allows you to change the color of the LED ring of the headlight on the fly. With 16 colors to choose from you can have a different look every day. Kit includes two headlamp assemblies with a multi-color LED ring, two removeable H4 bulbs, dust boots, RGB harness, ceramic pigtail and a wireless remote.



All SMD, White	#17940.....	\$99.95/pr.
All SMD, Multi-Color, w/ Remote, 7"	#17941.....	\$159.95/kit
All COB, White, 7"	#18997.....	\$119.95/pr.
All COB, Multi-Color, 7"	#18998.....	\$189.95/ea.

2-Headlight Relay Harness

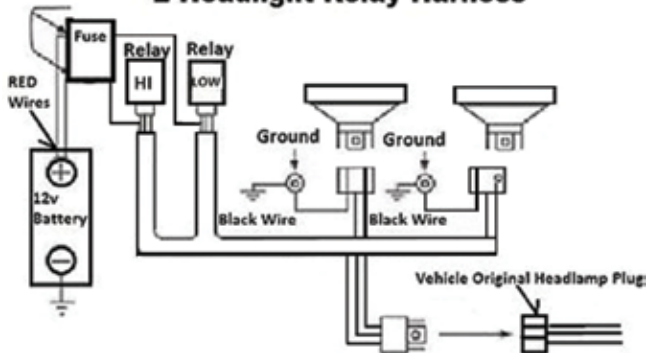

1. Plug in and install headlamp.
2. Ground both black wires from headlamp plugs.
3. Attach single red wire to Positive battery.
Single red wire now powers both relays.
4. Plug harness to original vehicle headlamp plug.



H4 HEADLIGHT RELAY HARNESS

Installing the latest H4 or other headlight technology in your classic? Want to get the most out of your stock OE or aftermarket headlights? This relay kit allows maximum voltage to the headlights and takes the load off of the headlight switch making it run cooler and last longer. Headlight relay kits are HIGHLY recommended when installing high performance headlights, such as H4 and other halogen bulb types. With the extra current draw that aftermarket halogen headlights put on the stock headlight switch, the safety circuit can sometimes trip. Works with bulbs with OE style terminals. Not required when using H.I.D. or LED lights.

All.....	#16826.....	\$34.95/ea.
----------	-------------	-------------

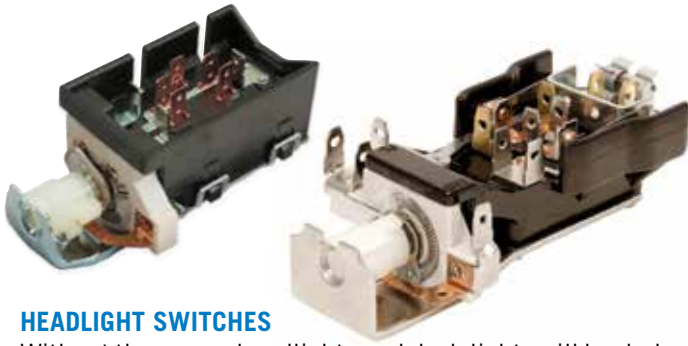

HEADLIGHT SWITCHES

Without these your headlights and dash lights will be dark. Our #117A is an exact reproduction of the GM original with the built in fuse. So, if your original is giving you trouble, we have the switch for you. Also listed in Switches section on page 274. We highly recommend replacing the retaining nut as well.

1955-56, '55-59 Truck, '55-57 Vette	
..... #117A.....	\$39.95/ea.
1957-63	#117.....\$29.95/ea.



GLASS DOTS . . . JUST LIKE BACK IN THE 50'S!

All Blue, Smooth, 15/16".....	#15993.....	\$13.95/pr.
All Red, Smooth, 15/16".....	#15994.....	\$13.95/pr.
All Amber, Smooth, 15/16"	#15995.....	\$13.95/pr.
All Clear, Smooth, 15/16".....	#15996.....	\$13.95/pr.
All Rainbow, Smooth, 15/16".....	#15997.....	\$13.95/pr.
All Green, Smooth, 15/16".....	#15998.....	\$13.95/pr.
All Blue, Faceted, 15/16"	#15999.....	\$13.95/pr.
All Red, Faceted, 15/16"	#16000.....	\$13.95/pr.
All Amber, Faceted, 15/16".....	#16001.....	\$13.95/pr.
All Clear, Faceted, 15/16".....	#16002.....	\$13.95/pr.
All Rainbow, Faceted, 15/16"	#16003.....	\$13.95/pr.
All Green, Faceted, 15/16"	#16004.....	\$13.95/pr.
All Yellow, Faceted, 15/16"	#16005.....	\$13.95/pr.



1955-56 HEADLIGHT SWITCH RETAINING NUT

1955-56 Stainless	
..... #13845.	\$19.95/ea.



1957 HEADLIGHT SWITCH RETAINING NUT

1957 w/ Nylon Insert	
..... #11206.	\$12.95/ea.



CLASSIC UPDATE REPLACEMENT HEADLIGHT SWITCH WITH CONNECTOR

Replacement switch for cars using the American Autowire Classic Update series wiring kits.

1955-57	#17803.....	\$29.95/ea.
----------------------	-------------	-------------

CLASSIC UPDATE REPLACEMENT HEADLIGHT SWITCH RETAINING NUT

Replacement retaining nut for the headlight switch on cars using the American Autowire Classic Update series wiring kit.

1955-56	#17802.....	\$13.95/ea.
----------------------	-------------	-------------



GLASS REFLECTORS

All Dark Blue, Smooth, 15/16".....	#16006.....	\$16.95/pr.
All Light Blue, Smooth, 15/16".....	#16007.....	\$16.95/pr.
All Red, Smooth, 15/16".....	#16008.....	\$16.95/pr.
All Amber, Smooth, 15/16"	#16009.....	\$16.95/pr.
All Clear, Smooth, 15/16".....	#16010.....	\$16.95/pr.
All Rainbow, Smooth, 15/16".....	#16011.....	\$16.95/pr.
All Green, Smooth, 15/16".....	#16012.....	\$16.95/pr.
All Blue, Faceted, 15/16"	#16013.....	\$16.95/pr.
All Red, Faceted, 15/16"	#16014.....	\$16.95/pr.
All Clear, Faceted, 15/16"	#16015.....	\$16.95/pr.
All Rainbow, Faceted, 15/16"	#16016.....	\$16.95/pr.
All Green, Faceted, 15/16"	#16017.....	\$16.95/pr.
All Yellow, Faceted, 15/16"	#16018.....	\$16.95/pr.



COMPLETE 1956 PARKLIGHT HOUSING ASSEMBLY



Just another example of our attention to detail. The 1956 parklight backing plates

are a series of complex contours stamped out of the finest steel. The parklight housings are cast from molds produced by our master toolmakers in Santa Ana, California. We hand work the castings until they are perfect and then both the backing plates and housings are treated to the finest show quality chrome plating you can get. **Made in the USA***.

PARKLIGHTS

1956 Best, Housing Assembly Only.....	#1080A*	\$199.95/set
1956 Good, Housing Assembly Only.....	#17687	\$145.95/set
1956 Backing Plates Only, Best.....	#1081*	\$169.95/pr.
1956 Backing Plates Only, Good.....	#16723	\$109.95/pr.
1956 Housings & Backing Plates	#15017*	\$359.95/set



1955 PARKLIGHT HOUSING ASSEMBLIES



It's parts like these that we built our reputation on. These housings are absolutely gorgeous, featuring show quality chrome plating, correctly pressed in light bulb housings, new lenses, sockets and cables, light bulbs, gaskets and mounting hardware and most importantly **Made in the USA.**

1955.....	#533.....	\$179.95/set
-----------	-----------	--------------



1957 PARKLIGHT HOUSINGS

Whether you've replaced your grille bar, or just want to brighten up your parklights, our reproduction housings are the way to go. Brilliant plating reflects more light from inside the parklight housing. You'll find installation easy, and connection into the wiring harness a snap. Get a pair of lenses and light bulbs while you're at it, you'll be amazed at the brilliance!

1957.....	#2357.....	\$29.95/pr.
-----------	------------	-------------



Photo courtesy of GERTMAN2000



PARKLIGHT, TAILLIGHT AND BACK-UP LENS SCREW SETS

Highlight your new lenses with new assembly hardware. These screws are stainless and won't rust or corrode, and can be polished to a mirror finish. 1957 kit does not include the back-up lens screws. **Made in the USA.**

1955.....	#1908.....	\$5.95/set
1956.....	#1909.....	\$5.95/set
1957.....	#1060.....	\$5.95/set

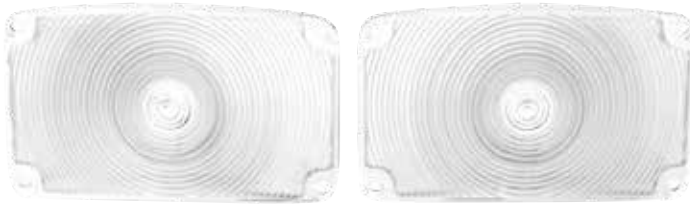

#490



#486A



#486

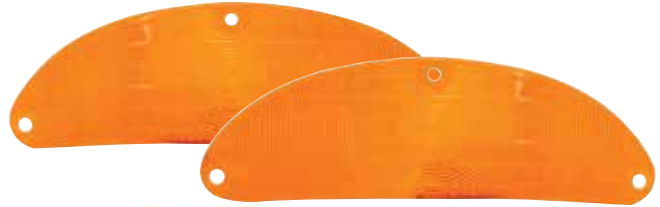

#494A



#494



#494A

PARKLIGHT LENSES



We produce all of our lenses in-house for the highest quality control. Our plastic part production was founded on the 1957 lens, and that success led to the 1955 and 1956 lenses. We feel proud of the beautifully polished, mirror-like surfaces found on our entire line of plastic parts, faithfully reproduced since 1977. Gaskets and hardware not included. See page 79 for gaskets and page 76 for screw sets. **Made in the USA.**

1955 Clear.....	#486.....	\$12.95/pr.
1955 Amber	#486A.....	\$12.95/pr.
1956 Clear.....	#490.....	\$12.95/pr.
1956 Amber	#490A.....	\$12.95/pr.
1957 Clear.....	#494.....	\$12.95/pr.
1957 Amber	#494A.....	\$12.95/pr.



LED PARKLIGHT CONVERSIONS

Update your lights with this easy to install LED conversion. Features super bright LED's with polycarbonate lens. Electronics are fully sealed against the elements and comes with 1157 style plug for easy hook-up. Don't forget the electronic flasher #13677 for proper operation. See page 79 for gaskets, page 76 for screw sets and page 66 for flasher. **Note: Modification to lens needed for the 1955 versions.**

1955 Amber w/ Clear Lens	#15564.....	\$37.95/ea.
1955 Amber w/ Amber Lens.....	#15565	\$37.95/ea.
1956 Amber w/ Clear Lens	#15566.....	\$41.95/ea.

PARKLIGHT LENSES WITH BOWTIE

Gaskets and hardware not included. See page 79 for gaskets and page 76 for screw sets.

1955 Clear.....	#10470.....	\$34.95/pr.
1955 Amber	#10471	\$34.95/pr.
1955 Amber w/ Chrome.....	#10472.....	\$34.95/pr.
1955 Clear w/ Chrome	#10477	\$34.95/pr.
1956 Clear.....	#10473.....	\$34.95/pr.
1956 Amber	#10474.....	\$34.95/pr.
1956 Amber w/ Chrome.....	#10480.....	\$34.95/pr.
1956 Clear w/ Chrome	#10481	\$34.95/pr.
1957 Clear.....	#10475.....	\$34.95/pr.
1957 Amber	#10476.....	\$34.95/pr.
1957 Amber w/ Chrome.....	#10484.....	\$34.95/pr.
1957 Clear w/ Chrome	#10485.....	\$34.95/pr.



#483

BACK-UP LIGHT LENSES



Our lenses are real show-stoppers! These intricate lenses require attention to detail to retain the same quality of the originals that can only be found on Danchuk reproductions. The 1957 lens is cast in glass, just like they were made by Chevrolet. The complete 1957 back-up light assembly, part #310, can be found on page 79. Gaskets and hardware not included. See page 79 for gaskets and page 76 for screw sets. **Made in the USA.**

1955	#483.....	\$12.95/pr.
1955 Red, Custom	#483B.....	\$18.95/pr.
1956.....	#488.....	\$12.95/pr.
1956 Red, Custom	#488B.....	\$18.95/pr.
1957 Glass.....	#492.....	\$20.95/pr.



#488



#492



BACK-UP LIGHT STAINLESS CONVERSION PLATES



Because back-up lights were optional in 1955 and 1956, many cars today still don't have this necessary feature. Along with the back-up light conversion plates, you'll need one wiring harness, found on page 251; two bulbs, found on page 82 and a neutral safety switch, found on page 276. Our back-up light conversion plates are made of durable stainless steel and sold in pairs. **Made in the USA.**

1955-56	#1875.....	\$16.95/pr.
---------------	------------	-------------



BACK-UP LIGHT SWITCH

For standard transmission. 1957's have a different bolt-on arrangement.

1955-56	#12149.....	\$26.95/ea.
---------------	-------------	-------------



1957 BACK-UP LIGHT COVER RETAINER BRACKETS

For use with part #219, shown at left, below. Includes mounting hardware.

1957.....	#979.....	\$9.95/pr.
-----------	-----------	------------



1957 BACK-UP LIGHT COVER

For those cars without the accessory back-up light assembly. Two per car. Retainer bracket shown at right.

1957.....	#219.....	\$36.95/ea.
-----------	-----------	-------------

1955 BACK-UP LENS RETAINING CLIP



Installs at the bottom of the back-up light lens and holds the lens to the taillight housing. Two required per car. For back-up lens screws sets, please see page 76. **Made in the USA.**



1955.....	#2177.....	\$3.95/ea.
-----------	------------	------------



1957 BACK-UP LIGHT ASSEMBLY 

We manufactured this unit with two things in mind. One, to duplicate the original exactly. Two, to uphold the superb workmanship you are so used to. Yes, a picture is worth a thousand words, but you'll still have to see the quality of these parts to believe it! Wiring kit #406 is included.
Note: You will also need a neutral safety switch or back-up light switch. Switches found on pages 275-276.
 1957..... #310..... \$169.95/set

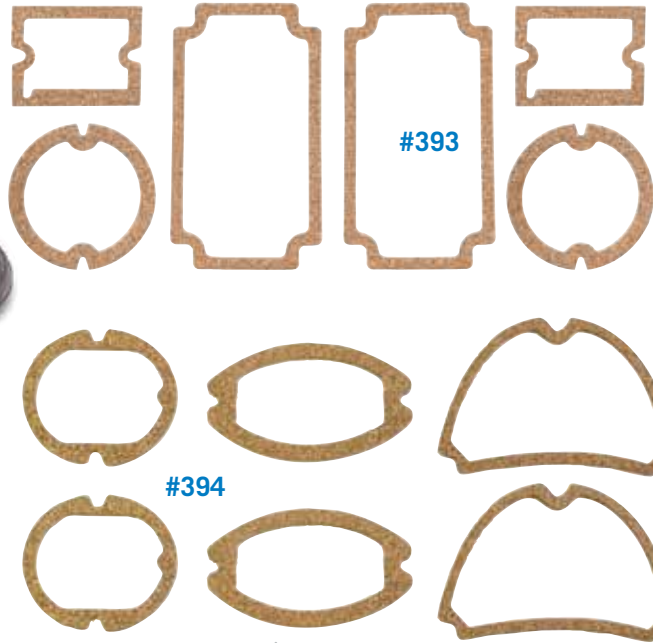

LENS GASKET SETS 

Each set includes gaskets for the parklights, back-up lights, and taillights. Our durable, original design gaskets are made of a cork and rubber combination that is designed to outlast either material alone. **Made in the USA.**

1955.....	#392.....	\$9.95/set
1956.....	#393.....	\$9.95/set
1957.....	#394.....	\$9.95/set



1957 BACK-UP LIGHT COVER WITH RETAINERS AND SCREWS

1957..... #17415..... \$69.95/pr.



1957 TRUNK LIGHT ASSEMBLY

1957..... #18161..... \$34.95/ea.



1957 LED BACK-UP LIGHT LENS

1957 with 1156 Plug..... #18975..... \$34.95/ea.



REPLACEMENT TRUNK AND UNDERHOOD LIGHT KIT

All..... #12349..... \$28.95/ea.

1955-57 SEDAN & WAGON, 1956-57 HARDTOP



DOME LIGHT HOUSING

Use with lens #212 and bezel #212A.

1955-57 and also 58-60 Sedan & Wagon
..... #12525..... \$28.95/set

DOME LENS

The heat of the dome light will yellow almost any plastic, and eventually wears the old lens out. The ideal solution is this dome lens, correctly reproduced to fit.



1955-57..... #212..... \$10.95/ea.

DOME LENS BEZEL

Beautifully plated in brilliant chrome, this bezel uses a #212 lens, shown above. One bezel required per car.



1955-57 #212A..... \$15.95/ea.

LED DOME LIGHT ASSEMBLY

Not just a conversion kit, but the entire dome light assembly. Includes housing, bezel and lens with LED circuit board installed.



1955-57..... #16819..... \$69.95/ea.

LED DOME LIGHT HOUSING CONVERSION

Try these high efficiency dome lights that use 90% less power than ordinary lights, are two to three times brighter than the old standard and don't heat up. Plugs directly into the dome light housing, #12525.



1955-57 and also 58-60 Sedan & Wagon
..... #14973..... \$34.95/ea.

1955-57 NOMAD, 1955 HARDTOP

DOME LIGHT HOUSING AND LENS

Another rare and beautiful reproduction from Danchuk. We created all new tooling from the ground up to produce this exquisite piece. Each includes the bezel, socket and lens. Two required per car.



1955-57..... #214..... \$35.95/ea.

DOME LENS

Only high-quality plastic and original design molds are used to produce this rare lens. Specialty items like this are what made Danchuk Manufacturing the industry leader. Two per car. **Made in the USA.**



1955-57 #213..... \$9.95/ea.

1955-57 NOMAD

NOMAD CARGO AREA LIGHT SWITCH WITH BEZEL

Tired of not being able to see when you open the gate on your Nomad? This complete cargo area dome light switch assembly will cure the problem. Comes complete with the switch, bezel and mounting screws so you can easily mount it in your cargo area.



1955-57..... #16234..... \$36.95/ea.

DOME LIGHT SWITCH COVER

This is for the manual dome light switch that is located in the cargo area on Nomads.



1955-57 Rear, Nomad #12619..... \$7.95/ea.

DOME LIGHT LENS HARNESS GROMMET

This harness grommet installs in the upper trunk wall over the passenger side wheel well. It serves to keep the wires from chafing on the metal and possibly causing a short.



1955-57 Hardtop..... #811..... \$5.95/ea.

CHROME ELLIPTICAL DOME LIGHT ASSEMBLY

Measures 4.5 inches by 2 inches by .75 inches.



All w/ Lens #18812..... \$69.95/ea.



LICENSE LIGHT HOUSING ASSEMBLIES

Our complete assembly includes a pair of lenses, gaskets, housings, bulbs, and wiring, ready to install. License bezels for Nomad and wagon shown below. Must drill out housing threads on wagon applications.

- 1955 All Models; '56-57 Wagon, Nomad & Sedan Delivery #485B..... \$46.95/set
- 1956 Hardtop, Sedan & Convertible (Shown) #485C..... \$46.95/set



1957 LICENSE PLATE LIGHT ASSEMBLY

Our 1957 license light assembly is true to the GM original in every way. The lenses are painted correctly, like original, and the light bulb socket is wedged in place, just like the original. The only difference is that the housing has the same show quality chrome job that we put on all our chrome parts. Will not work on Nomad, wagon or sedan delivery. **Made in the USA.**

- 1957 Hardtop, Sedan & Convertible #500..... \$62.95/set



#485

LICENSE LIGHT LENSES

We included all the original markings in our mould designs, making these lenses virtually indistinguishable from original production parts. All lenses are injection moulded in crystal clear plastic. Our 1957 lens includes an original design rubber/cork gasket made of the highest quality materials. Hardware not included. **Made in the USA.**

#493

- 1955-56 All, 1957 Nomad, Wagon, Sedan Delivery, Clear #485..... \$9.95/pr.
- 1957 Hardtop, Sedan & Convertible, Clear #493..... \$12.95/ea.
- 1957 Hardtop, Sedan & Convertible, Amber #493A..... \$12.95/ea.



LICENSE LENS BEZELS

These beautiful chrome bezels are for use with all Nomads and wagons. **Made in the USA.**

- 1955-57 #231..... \$32.95/pr.



LICENSE LIGHT WIRE GROMMETS

- 1957 #1738..... \$5.95/pr.

LICENSE LENS GASKETS

This rubber gasket seals moisture and dirt out of the license light, and should be replaced whenever the license lens is removed. The license lens wire grommet, part #1193, shown at right, is also necessary to completely seal out moisture and dirt.



- 1955 All Models; 1956-57 Wagon, Nomad & Sedan Delivery #866..... \$8.95/pr.
- 1956 Passenger Models #866A..... \$6.95/pr.



1957 LICENSE LIGHT HOUSING SCREW SET

Set includes two screws with their correct retainer clips. **Made in the USA.**

- 1957.... #680..... \$3.50/set



HIGH POWER LED LIGHT BULBS

These high-powered bulbs give you 360 degrees illumination and are brighter and cooler than standard incandescent bulbs. Lenses are white and color only appears when illuminated.

- All 1156, White #19159 \$10.95/ea.
- All 1157, White #19160 \$10.95/ea.
- All 1157, Red #19161 \$10.95/ea.
- All 1157, Amber #19162 \$10.95/ea.



SMED LED LIGHT BULBS

- All 1156, White #19163 \$14.95/pr.
- All 1157, White #19164 \$14.95/pr.
- All 1157, Red #19165 \$14.95/pr.
- All 1157, Amber #19166 \$14.95/pr.



LED LIGHT BULB

- All White, 1156, Back-Up Light #12358 \$23.95/ea.

LIGHT BULB COVERS

AutoMeter's light bulb covers slip over your gauge's light bulb. These covers allow you to change the color of your backlighting.



- All Blue, 3-Piece Set..... #18085 \$9.95/set



- #18087
- #18088
- #18089
- #18090

T3 WEDGE LED BULBS

Upgrade your standard instrument lighting with intense LEDs. Replaces 161, 193, 194 and 168 style wedge base bulbs only. For all AutoMeter gauges (except clocks, Air/Fuel and Autogage), speedometers, and most in-dash tachometers. Does not work with digital and LED lit gauges.

- All Red #18087 \$14.95/ea.
- All Green #18088 \$16.95/ea.
- All Blue #18089 \$16.95/ea.
- All White #18090 \$14.95/ea.

- #122
- #123
- #124
- #125
- #126
- #127
- #127A



LIGHT BULBS

We offer the whole family of light bulbs for the 1955-57 Chevy. Don't procrastinate replacing that burned-out bulb!

- 1955-57 Parklight & Taillight (1157) #122 \$0.95/ea.
- 1955-57 Dome exc. '55 Hardtop, '55-57 Nomad (1104) #123 \$0.95/ea.
- 1955-57 '55 Sport Coupe & '55-57 Nom - Rear Quarter (90) #124 \$0.95/ea.
- 1955-57 License, Parklight (w/o Directional Flash), 1955-56 Clock (67) #125 \$0.95/ea.
- 1955-57 Dash Lights: Turn Signal, Hi Beam, Ignition (53) #126 \$0.95/ea.
- 1955-57 Instrument Cluster, Oil Press, Gen, Glove Box, Heater Panel; '55-56 - Radio Dial; '55-56 PG Indicator, '57 Clock (57)..... #127 \$1.15/ea.
- 1955-57 Back-Up Lights (1156)... #127A \$0.95/ea.



TRANSMISSION INDICATOR LENSES

These lenses indicate the correct shifting sequence for original powerglides or automatic transmissions that have been updated. All lenses are printed in the correct colors. **Made in the USA***.

- 1955-56 TH350-400 #929..... \$17.95/ea.
- 1955-56 Powerglide (Stock) #298C* \$14.95/ea.
- 1955-56 700-R4/200-4R #10248..... \$27.95/ea.
- 1957 TH350-400 #930* \$18.95/ea.
- 1957 Powerglide (Stock) #1059* \$16.95/ea.
- 1957 700R4/200-4R #10469..... \$24.95/ea.

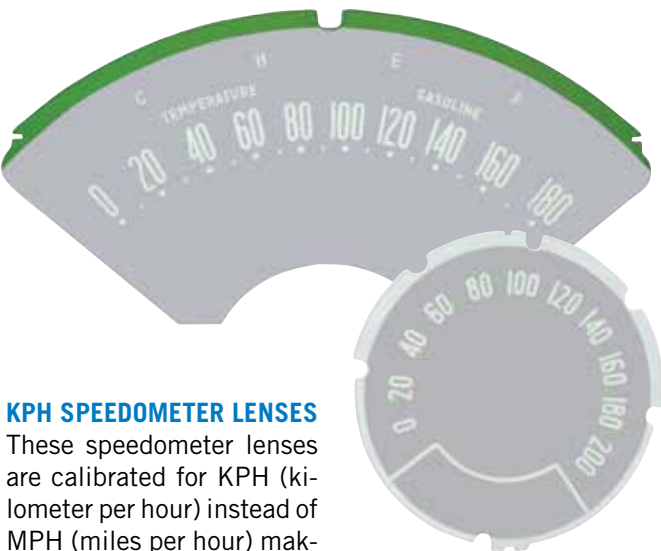

KPH SPEEDOMETER LENSES

These speedometer lenses are calibrated for KPH (kilometer per hour) instead of MPH (miles per hour) making it perfect for anyone restoring one of these cars outside of the U.S. Part #18940 will not work on any right hand drive cars. Please note all lenses are clear, but grayed to show details in photo. **Made in the USA.**

- 1955-56 #18939..... \$23.95/ea.
- 1957..... #18940..... \$23.95/ea.



COLUMN MOUNTED SHIFT INDICATOR LENSES

- 1955-57 w/ Aluminum Housing, 700-R4/200-4R
Overdrive #13236..... \$89.95/ea.
- 1955-57 w/ Aluminum Housing, TH350-400
..... #13237..... \$89.95/ea.



1957 DASH INDICATOR LENSES AND COLOR INSERTS

If your "OIL" and "GEN" lenses have yellowed or cracked, these lenses are for you. Part #609B includes clear oil and generator lenses with black printed letters, two injection moulded red, and two injection moulded green inserts. For an inexpensive way to bring the color back to your faded inserts, order part #609A, our 1957 red and green color inserts.

- 1957..... #609B..... \$14.95/set
- 1957 Color Inserts Only #609A..... \$3.50/set

SHIFT INDICATOR SPRING BRACKET

The shift indicator spring bracket mounts around the shift tube and the column and connects the indicator wire rod to the shift indicator in the cluster.

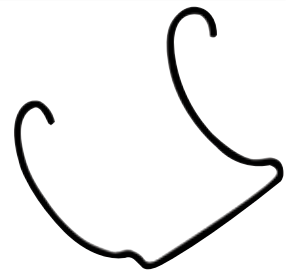

- 1955-56 #18596..... \$8.95/ea.



AUTO TRANSMISSION INDICATOR RETURN SPRING

This is the spring that keeps the shift indicator pointer moving back in place. Installs opposite the shift indicator wire rod on the shift indicator.

- 1955-56 #18163..... \$1.95/ea.

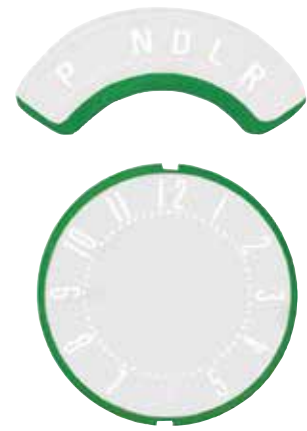
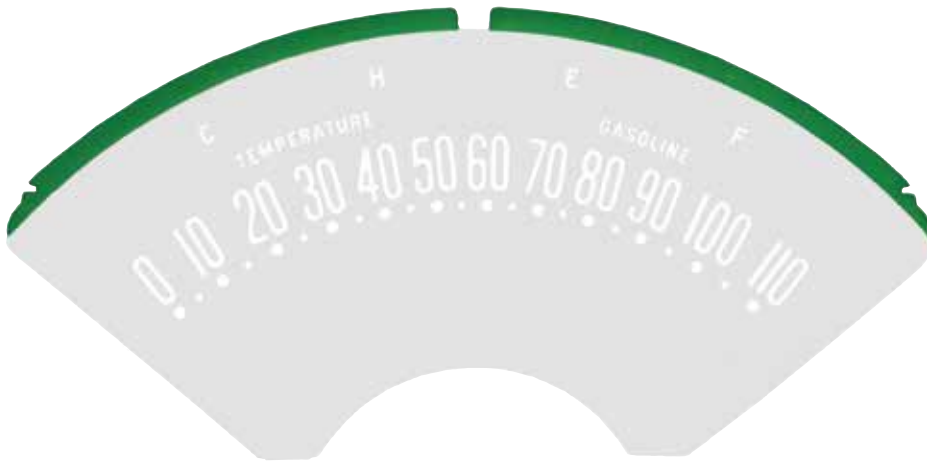

DASH LENSES Please note all lenses are clear, but grayed to show details in photo.

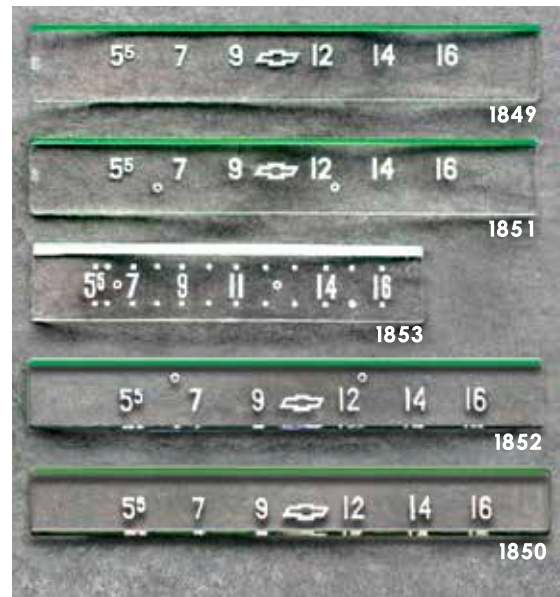

DASH LENS SETS

These highly polished, injection moulded lenses have been reproduced to duplicate the originals exactly. Our top-quality plastic and highly polished moulds make them the clearest lenses on the market. All numbers and letters are recessed on the back side and painted white. Edges of the lenses are painted green to transmit color to the letters when backlit, just like Chevy produced them in '55, '56 and '57. Please note all lenses are clear. **Made in the USA.**

SETS:

1955-56 Standard Transmission... #299.....	\$36.95/set
1955-56 Auto. Transmission #298.....	\$43.95/set
1957..... #300.....	\$64.95/set

SOLD SEPARATELY:

1955-56 Speedometer, Standard & Automatic #298A.....	\$29.95/ea.
1955-56 Clock Face, Standard & Auto.; 1958-62 Vette #298B.....	\$19.95/ea.
1955-56 Trans. Indicator, Powerglide #298C.....	\$14.95/ea.
1957 Speedometer #300A.....	\$29.95/ea.
1957 Temperature Gauge #300B.....	\$19.95/ea.
1957 Gas Gauge #300C.....	\$20.95/ea.
1957 Clock Face #300D.....	\$18.95/ea.

RADIO LENSES

Whether you're removing the radio for service or want to detail the dash, remember to replace the radio lens. Sharp details are cast in crystal clear quality acrylic. Letters and numbers are recessed and painted white.

1955 Pushbutton	#1849.....	\$33.95/ea.
1955 Wonder Bar	#1850.....	\$33.95/ea.
1956 Pushbutton	#1851.....	\$33.95/ea.
1956 Wonder Bar	#1852.....	\$35.95/ea.
1957 Pushbutton or Wonder Bar ...	#1853.....	\$33.95/ea.

#1282



HEATER CONTROL FACE PLATE AND LENSES

Plastic parts can yellow and crack with age. These face plates are crystal clear! Printed in white and green as they were originally.

1955-56	#1281.....	\$27.95/ea.
1957.....	#1282.....	\$23.50/ea.

#1281

