

4. Electrical & Audio

SECTION AT A GLANCE:

Battery	234
Fuse Related	239
Generators	241
Starters	242
Alternators	244
Wiring Harnesses	247
Cruise Control	252
Electronic Additions.....	253
Radio & Related	254
Speakers.....	256
Custom AutoSound	257
Antenna.....	260

OPTIMA BATTERY

The Optima red top battery is the perfect battery for your project car. It will retain it's charge for over 6 months without starting, take a full charge in 2-3/4 hours at 20-amps, last 3-4 times longer than a regular battery and is 100% maintenance free; so it never needs water and will not produce corrosion on the top posts, cables or connectors. Rated at 800 cold cranking amps. 34/78 Series. Warranty is handled by the manufacturer.



1955-71 #2581 \$219.95/ea.



TAYLOR ALUMINUM TRUNK MOUNT BATTERY BOXES

Use this NHRA approved 3-piece aluminum battery box to mount your battery anywhere or order the complete kit to relocate the battery to the trunk for better weight distribution. Battery dimensions are 13-1/2" long x 9-1/2" wide x 10" high. Optima and Odyssey boxes are slightly smaller.

- All w/ Hold Down #12993..... \$124.95/kit
- All w/ 16 ft. 1-Gauge Battery Cable #12994..... \$249.95/kit
- All for Optima & Odyssey #14249..... \$129.95/kit
- All for Optima & Odyssey w/ 1-Gauge Cable #14250..... \$264.95/kit



OPTIMA 34/78 SERIES BILLET BATTERY BOXES

These billet battery boxes by Eddie Motorsports are designed to work with group 34/78 sized standard Optima batteries. Some minor modifications to the original battery box may be required.

- 1955-57 Polished..... #16250..... \$110.95/ea.
- 1955-57 Flat Black..... #16251 \$118.95/ea.



TAYLOR TRUNK MOUNT BATTERY BOXES

Battery trunk mount kits come with all the needed hardware to easily relocate your battery to the trunk. Battery tray is 13" x 7-1/4".

- All w/ 2-Gauge Battery Cable, Single Battery #12995..... \$129.95/set
- All w/ 1-Gauge Battery Cable, Single Battery #12996..... \$159.95/set



EDDIE MOTORSPORTS BILLET BATTERY BOXES

These billet battery boxes are machined from 6061-T6 billet aluminum and are a direct replacement for your original 1955-1956 battery box. They come with stainless steel mounting fasteners and they will clear the EMS billet hood hinges. These will work with any Group 78 side post or D34 & R34 top post battery. Firewall pinch weld and hole slotting modifications may be necessary. Fusioncoated colors available by special order, allow 2-4 weeks for delivery, numbers below are stocked.

- 1955-56 Machined, for 78 Battery #18010..... \$172.95/ea.
- 1955-56 Polished, for 78 Battery . #18011..... \$201.95/ea.
- 1955-56 Machined, for Optima..... #18012..... \$172.95/ea.
- 1955-56 Polished, for Optima #18013..... \$201.95/ea.



BATTERY BOXES

The battery box is the first part in any car to corrode. This sturdy reproduction is powder coated in a durable black finish and designed to endure many years of wear and tear. Order a hold-down kit and a new set of hold down pads, shown on page 236, for a complete assembly.

- 1955-56 Best..... #311..... \$38.95/ea.
- 1955-56 Good..... #16698..... \$28.95/ea.
- 1957 Best..... #313..... \$38.95/ea.
- 1957 Good..... #16699..... \$29.95/ea.



BATTERY HOLD-DOWN KITS



Has corrosion done yours in? Replace it now! Includes hold-down frame, "J" bolts, and nuts. For a flashier version, the beautifully chromed, #312C and #314C are show stoppers. **Made in the USA***.

- 1955-56 Best, Black (Shown) #312* \$20.95/kit
- 1955-56 Good, Black, Frame Only #16770..... \$12.95/kit
- 1955-56 Chrome (Shown)..... #312C..... \$74.95/kit
- 1957 Best, Black..... #314* \$17.95/kit
- 1957 Chrome #314C..... \$129.95/kit



CHROME BATTERY BOXES

- 1955-56 Battery Box Only #13303..... \$129.95/ea.
- 1957 Battery Box Only #13304..... \$129.95/ea.



OPTIMA BATTERY HOLD-DOWN KIT

Fits Optima 34/78 Series batteries. Will work with original tray.

- 1955-56 Billet Aluminum w/ Hardware #15513..... \$104.95/kit

WARNING! Products on these pages may contain chemicals known to the State Of California to cause cancer and/or birth defects or reproductive harm. www.p65warnings.ca.gov



AUTO METER BATTERY EXTENDERS

These battery extenders from Auto Meter are designed to maximize the life of your standard (wet cell), AGM or gel battery and once they have fully charged the battery they change from charging amperage (1.5 or 3 amps) to a 250 milliamp current to maintain a full charge. This prevents sulfation, the main reason for premature battery failure.

- All 12V/1.5A..... #18095..... \$45.95/ea.
- All 12V/3A..... #18096..... \$59.95/ea.



BATTERYMINDER

The BatteryMINDER® is a 3-mode charger/maintainer/conditioner that extends performance and life of all types of 12 volt lead acid batteries, the perfect charger for keeping your battery in shape between show seasons. The BatteryMINDER® automatically dissolves harmful power robbing sulphation using patented high frequency technology, and it's guaranteed to increase your battery's life and performance or you get 100% of your money back from the manufacturer within one year. Includes battery clip cord set with quick connect and ring terminal cord set with quick connect.

- All..... #16628..... \$59.95/ea.

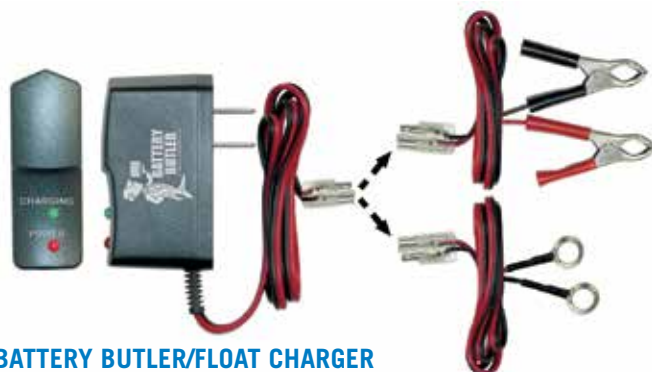

BATTERY BUTLER/FLOAT CHARGER

The battery butler battery storage charger will prevent the normal self-discharge of your battery while maintaining and extending battery life. This charger is designed for safe long term use and keeps your battery fully charged without overcharging. Just hook it up to your battery, plug the charger into any wall outlet and forget about it for weeks, months, even years.

- All..... #12813..... \$17.95/ea.



1957 BATTERY HOLD-DOWN KIT

Each plastic coated bracket has an extra smooth, glossy finish and is an identical match to the Chevy version.

- 1957..... #1784..... \$26.95/kit



BATTERY HOLD-DOWN RUBBER PADS

Fight battery acid corrosion with these handy little rubber pads. Mount them to the top of your battery to keep the metal frame away from those damaging chemicals! **Made in the USA.**

- 1938-68 #1279..... \$7.95/set



BATTERY CABLES

Sturdily constructed replacement cables in all the original lengths. Get rid of those corroded oldies.

- 1955-56 V8 & 6-Cyl.,(-)..... #132..... \$17.95/ea.
- 1955-56 V8, (+)..... #136..... \$29.95/ea.
- 1955-56 6-Cyl.,(+)..... #131A..... \$24.95/ea.
- 1957 V8 & 6-Cyl., (-)..... #133A..... \$19.95/ea.
- 1957 V8, (+)..... #137..... \$29.95/ea.
- 1957 6-Cyl., (+)..... #135..... \$29.95/ea.



ORIGINAL DESIGN BATTERY CABLES

These battery cables are manufactured according to original drawings, and include the correct printed markings.

- 1955 (+) 6-Cyl. Before 8/22/55, 29"..... #18769..... \$45.95/ea.
- 1955-56 (+) 6-Cyl. After 8/22/55, 21"..... #2168..... \$45.95/ea.
- 1957 (+) 6-Cyl. #2169..... \$45.95/ea.
- 1955-56 (+) V8 #2170..... \$45.95/ea.
- 1957 (+) V8..... #2171..... \$45.95/ea.
- 1957 (-) V8 & 6-Cyl. w/ Factory A/C..... #2172..... \$45.95/ea.
- 1955-56 (-) V8 & 6-Cyl. w/ Factory A/C..... #2173..... \$45.95/ea.
- 1955-56 (-) V8 & 6-Cyl. w/o Factory A/C..... #2174..... \$45.95/ea.
- 1957 (-) 6-Cyl. w/o Factory A/C #2175..... \$45.95/ea.
- 1957 (-) V8 w/o Factory A/C..... #2176..... \$45.95/ea.



TRUNK MOUNTED BATTERY CABLES

Comes with 20 feet positive and 15 feet negative 1/0 gauge cables with lugs and crimp tool.

- All Top Post Style..... #15441..... \$164.95/kit
- All Side Post Style #15442 \$159.95/kit



BATTERY CABLE KITS WITH CRIMP TOOL

This is an underhood 1-gauge cable kit. You get 6 foot each of red and black 1-gauge cable, terminal lugs, crimp tool and shrink tubing. Also, the negative cable has a 36 inch 10-gauge secondary cable built in. Make sure you order the correct kit for your battery. Side post or top post.

- All Top Post, 1-Gauge..... #13585..... \$115.95/ea.
- All Side Post, 1-Gauge #13586..... \$104.95/ea.

BATTERY CABLE CRIMPING STAR TOOL

Use the star tool with your vise and get a professionally strong and conductive crimp every time. Works with all sizes of battery cables.



- All..... #13587..... \$13.95/ea.

BATTERY/STARTER GROUND WASHER

This is the tanged washer that goes between the ground cable from the battery and the firewall as well as between the ground cable and the firewall on the starter ground cable. It digs into the cable ends and the face to the firewall to provide a good ground.



- 1955-56 #1280..... \$1.95/ea.

BATTERY HOLD-DOWN WASHERS



- 1955-56 #18022..... \$2.95/pr.

BATTERY



REMOTE MASTER DISCONNECT SWITCH

The Painless® remote master disconnect kit with latching solenoid is a simple and effective anti-theft deterrent for everyday vehicles. The 110-amp continuous duty solenoid is activated by an easy to hide momentary push button. No risk of accidentally draining your battery with the latching solenoid. Includes constant-hot wire for computer or radio presets.

All w/ Latching Solenoid..... #14617..... \$118.95/ea.



UNIVERSAL GAUGE DISCONNECT KIT

This kit enables you to create a completely disconnectable gauge harness for speedometer, tachometer, oil pressure, water temperature, volt, and fuel gauges. Includes terminals for blade or stud mount connections, connector and terminals for electronic speedometer connection and complete instructions.

All..... #12343..... \$99.95/kit

REMOTE MASTER DISCONNECT SWITCH KIT

This kit allows you to shut off the battery remotely. Kit contains one single pole, single throw switch with 5/16" posts rated at 110-amp continuous, 2 battery cable ends, crimping tool, enough wire to install into most applications and complete instructions.

All..... #15443..... \$103.95/kit



#18356



#15445

#15444

LIFELINE MEMORY RETENTION SYSTEMS

The Lifeline enables users of a master disconnect switch to retain a small amount of power for memory circuits common in fuel injection computers, radio presets and clocks. The Lifeline is a memory circuit retainer that will automatically reset after the electrical load is significantly reduced or if the master or remote disconnect switch has been switched to the on position.

All For Disconnect Switch..... #15444 \$29.95/ea.

All For Remote Disconnect..... #15445 \$37.95/ea.



#12369

WIRE HARNESS DISCONNECT PLUGS

Ever need to pass wires through a panel with no secure way to do it? Now offered is this disconnect system which makes gaining access or troubleshooting much easier.

All 6-Wire #18356..... \$16.95/kit

1955-57 9-Wire #12369..... \$21.95/kit

MASTER DISCONNECT SWITCH KIT

A master disconnect switch protects against theft and electrical failures. Flexible mounting locations. Switch engineered with 3/4" - 16 thread, fits 3/4" hole. Rated at 175-amp continuous or 1,000-amp intermittent. Includes protective insulated rubber boots and instructions.
All..... #15446..... \$33.95/kit

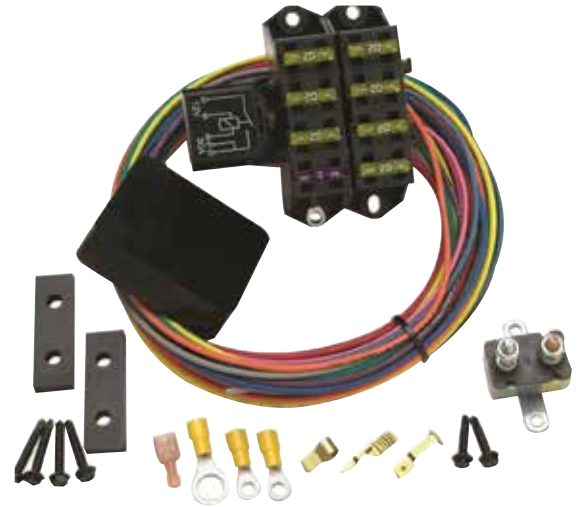

CIRKIT BOSS AUXILIARY FUSE BLOCKS

Painless Performance's Circuit Boss is a safe and right way to add additional circuits to your classic Chevy. Whether you have the latest 21-circuit wire harness or factory original wiring the Circuit Boss kits allow you to add ignition "on" and constant 12-volt circuits to your existing wiring.

- All 1-Hot, 2-Ign..... #18276..... \$79.95/kit**
- All 1-Hot, 2-Ign. Weatherproof..... #18277..... \$89.95/kit**
- All 3-Hot, 4-Ign..... #18278..... \$99.95/kit**
- All 3-Hot, 4-Ign. Weatherproof..... #18279..... \$119.95/kit**

MASTER DISCONNECT ON/OFF POSITION RING

For use with #15446 master disconnect switch.
All..... #15447 \$4.75/ea.



GROUND SPLICE SYSTEM

This ground splice system is the easiest way to assure that your dash or other system is grounded properly. The mounting tab will ground when you mount the connector or you can use a heavy gauge wire at the mounting tab to connect to the best ground source. Heavy gauge wire included.
All..... #13681 \$19.95/kit



GROUND BOX

This ground box allows you to centralize your grounding points for a cleaner more efficient wiring system and helps prevent grounding issues.
All..... #13584..... \$23.95/ea.

RADIO GROUND STRAPS

This kit contains three ground straps that were originally used with original AM radios, one for under the dash, one for under the hood from the firewall to the engine and one for under the car from the transmission to the floor pan inspection plate. Use for V8 or 6-cyl applications.
1955-57 #931 \$21.95/set



ENGINE GROUND STRAP

The engine ground strap installs between the lower starter mount and firewall / body.
1955-56 #12701 \$9.95/ea.

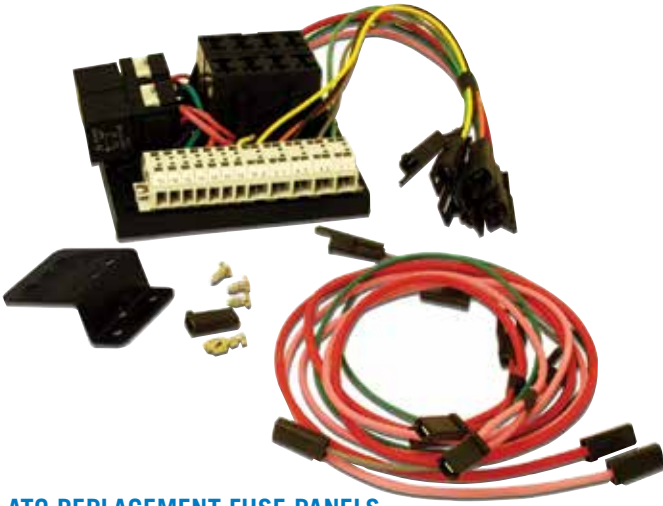

ATO REPLACEMENT FUSE PANELS

These fuse panel kits are designed to be more effective than the originals, and come complete and ready to install. Easy to follow instructions help you install a more comprehensive fuse solution. These panels will add fusing to heater, radio, back-up lights, dash lights, courtesy lights, dome lights, brake lights and clock. Also there are two ignition triggered relays that can be used for high-amp draw items.

- 1955 #12365..... \$124.95/ea.
- 1956-57 #12366..... \$124.95/ea.



AUXILIARY FUSE BLOCK BUSS ASSEMBLY

6 fuse with lead wire, side feed ring terminals and cover. Block measures 1-3/8" x 4-7/8" and carries a rating of 30-amperes maximum per circuit, 80-amp maximum per entire assembly.

- All..... #12352..... \$39.95/ea.

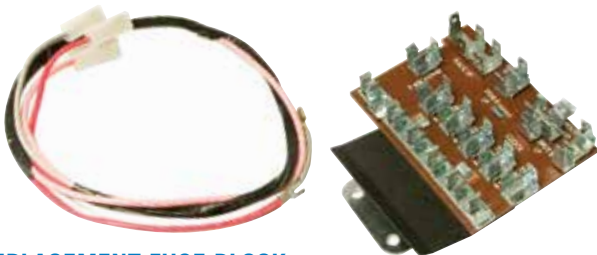

REPLACEMENT FUSE BLOCK

Correct for 1955, good replacement for 1956 and can be used on the 1957 but wiring will need to be modified.

- 1955-57 #1347..... \$44.95/ea.

GLASS FUSES

Universal AGA fast-acting 1/4" x 5/8" fuses come in blister packs.



- All 3-Amp, 5-Pack #19453..... \$3.95/ea.
- All 7.5-Amp, 5-Pack #19454..... \$1.95/ea.
- All 10-Amp, 5-Pack #19455..... \$1.95/ea.
- All 15-Amp, 5-Pack #19456..... \$1.95/ea.
- All 20-Amp, 5-Pack #19457..... \$1.95/ea.
- All 25-Amp, 5-Pack #19458..... \$1.95/ea.
- All 30-Amp, 5-Pack #19459..... \$1.95/ea.
- All Assorted, 60-Pack w/ Tester.... #19460..... \$24.95/ea.
- All SFE9, 5-pk #19485..... \$1.95/ea.
- All SFE 7.5 amp, 5-pk #19486..... \$1.95/ea.
- All AGW 4 amp, 5-pk..... #19487..... \$2.95/ea.

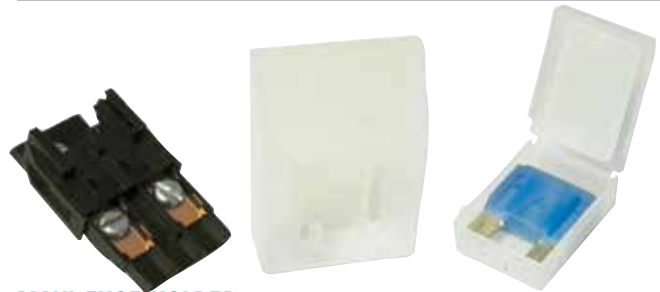

MAXI-FUSE HOLDER

Protect any circuit with the latest in in-line fuses. The Maxi-fuse holder comes with a nylon plastic holder with cover and a 60-amp fuse is perfect for those power hungry accessories.

- All 60-Amp #13673..... \$21.95/ea.



MEGA-FUSE HOLDER

- All 175-Amp #13675..... \$21.95/ea.



IN-LINE FUSE HOLDER

The waterproof fuse holder has an integral mounting tab and comes complete with terminals and a 30-amp fuse.

- All Waterproof #13676..... \$9.95/ea.



#1205/1206

#17257

GENERATOR MOUNTING BRACKETS

The 6" bracket was used on all cars without power steering. The 7" bracket was used on '55's with factory power steering. The 6-1/2" bracket was used on '56-'57's with factory power steering.

1955-57 6"	#1205	\$22.95/ea.
1956-57 6-1/2" w/ Power Steering	#17257	\$24.95/ea.
1955 7" w/ Power Steering	#1206	\$27.95/ea.



GENERATOR ADJUSTMENT BRACKET

After many years and much adjusting it may be time to replace that nicked, bent, or broken generator bracket.

1955-57 V8	#1299	\$39.95/ea.
------------------	-------------	-------------



1955 GENERATOR MOUNTING KIT

1955 2nd Style V8.....	#13533.....	\$12.95/kit
------------------------	-------------	-------------



GENERATOR MOUNTING HARDWARE KIT

For use on generators with mount bushings in end brackets.		
1956-57	#13565.....	\$4.95/kit



GENERATOR REBUILD KITS

Whether you do it yourself or send it out, these kits have all the parts needed to rebuild the generator. Part #1843 includes two terminal posts, two brushes, one oiler assembly, one bearing, one bushing, two oil caps nuts and washers. Part #2103 includes two terminal posts, two brushes, two bearings, two oil caps, screws, nuts and washers.

1955-65 exc. Power Steering (Shown)	#1843	\$54.95/kit
1955-65 w/ Power Steering	#2103	\$60.95/kit



OE STYLE VOLTAGE REGULATOR

For use with generators only.

1955-57	#130.....	\$82.95/ea.
---------------	-----------	-------------

STARTER, GENERATOR AND DISTRIBUTOR TAG FASTENER SET

With this kit you can drill out those old fasteners, confident that you have the hardware needed to reattach the tags to the components correctly.



1955-62	#2202.....	\$1.95/set
---------------	------------	------------

GENERATOR MOUNT BUSHING SLEEVE

This sleeve goes into the rubber bushing on the generator end plates, Check your generator to verify if you need one or two sleeves.



1956-61	#15535	\$2.25/ea.
---------------	--------------	------------

STARTERS

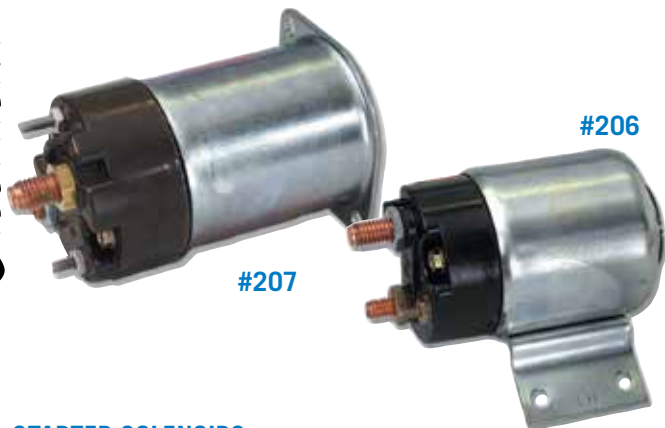

STARTER SOLENOIDS

These replacement starter solenoids install and function like the originals.

- 1955-56 #206 \$92.95/ea.
- 1957 #207 \$38.95/ea.



STARTER REBUILD KITS

- 1955-56 V8 & 6-Cyl. #13534 \$54.95/kit
- 1957-72 V8 & 6-Cyl. #13535 \$54.95/kit



THERMO-TEC STARTER HEAT SHIELD

Eliminate starter problems caused by excessive heat with this easy to install starter heat shield kit. Kit includes heat shield and straps.

- All 7" x 22" #13071 \$29.95/ea.



POWERMASTER SOLENOID "R" TERMINAL DIODE KIT

For use with Powermaster starters only.

- All #13259 \$26.95/kit

V8 STARTER MOUNTING KITS

All the fasteners you need to mount your starter. The #15437 kit contains four bolts and the #15438 contains three bolts, both kits include one stud, five lock washers and two nuts.



- 1955-56 V8 #15437 \$3.95/kit
- 1957 (Shown) #15438 \$3.95/kit



STARTER BOLTS AND SHIM KIT

All Inline Shims, Natural Finish

- #13243 \$13.95/set



STARTER BRACKET

This bracket bolts to the starter and the side of the block on all V8 applications.

- 1955-57 #1162 \$10.95/ea.



STARTER BRUSH SET

- 1955-57 #121 \$5.50/set



POWERMASTER XS TORQUE STARTERS

- All V8, LT-1 and ZZ-4, 153 Tooth Flywheel, 200 ft. lbs., for 18:1 Compression..... #13241..... \$224.95/ea.
- All V8 LS Engine #13242..... \$249.95/ea.
- All V8 w/ Inline Bolt Pattern, 200 ft. lbs., for 18:1 Compression, 168 Tooth Flywheel #13293..... \$228.95/ea.

POWERMASTER MINI-STARTERS

- These high torque mini starters feature dual bolt patterns and come with mounting bolts and shims. Not intended to replace 1955-56 original starters. Fits both small block and big block V8's.
- All 160 ft. lbs. #12892..... \$187.95/ea.
 - All 160 ft. lbs. Chrome #12893..... \$279.95/ea.

POWERMAX STARTERS

Powermaster offers several different starters with different torque ratings. Each starter comes with a Dyno Sheet showing speed, power, and torque which is the true measure of power for a starter.



- All 160 ft/lbs. 153/168 Tooth Flywheel, Inline Bolt Pattern #14043..... \$134.95/ea.
- All 160 ft/lbs. 168 Tooth Flywheel, Staggered Bolt Pattern #14044..... \$175.95/ea.



POWERMASTER MASTER TORQUE STARTERS

- Master Torque V8 with inline bolt pattern, 180 ft. lbs., for 12:1 compression.
- All 153/168 Tooth Flywheel..... #13239..... \$205.95/ea.
 - All 168 Tooth Flywheel..... #13240..... \$219.95/ea.

3-BOLT BELL HOUSING MOUNT STARTER

This Powermaster starter is just the ticket if you are having problems finding a decent replacement for your tired original. It looks original, but this bell housing mount starter has been beefed up with all the latest technology making it better than original. 168 tooth flywheel required.



- 1955-57 #18499..... \$155.95/ea.



STARTER SOLENOID BOOT

Engine heat and day to day wear require periodic inspection and replacement of this rubber part.

- 1955-56 #1406.....\$5.95/ea.



ARP STARTER BOLT KITS

- All Long & Short Bolts #18230..... \$21.95/kit
- All Medium Bolts #18231..... \$22.95/kit
- All Long Bolts #18232..... \$24.95/kit
- All Gen III/IV LS Engines..... #18233..... \$20.95/kit

DELCO-REMY DETAIL TAGS

You can rebuild your starter, distributor or generator, but until you've replaced those tarnished old tags, the job isn't finished. Rivets included.

- 1955-57 #994..... \$12.95/set

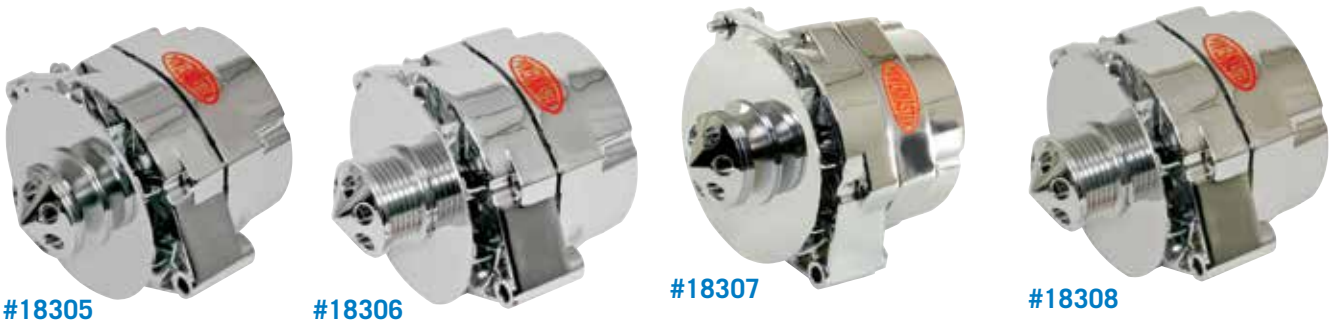

ALTERNATORS WITH BAFFLES AND CONES

Upgrading your charging system is a must in modern builds these days with all the additional electronics being put into cars. Alternators from Powermaster are just what you need to fill your charging needs. These alternators feature fan cones baffles for better cooling and looks. For the ultimate in good looks check out the Smoothie Series that feature a smoothed housing, hidden case bolts and are beautifully chrome plated. 150-amp models are recommended for cars with electric fans.

All 100-Amp, V-Belt, Chrome	#18305.....	\$169.95/ea.
All 100-Amp, 6-Groove, Chrome	#18306.....	\$175.95/ea.
All 150-Amp, V-Belt, Chrome	#18307.....	\$229.95/ea.
All 150-Amp, 6-Groove, Chrome	#18308.....	\$239.95/ea.
All 150-Amp, V-Belt, Smooth, Chrome	#18309.....	\$249.95/ea.
All 150-Amp, 6-Groove, Smooth, Chrome	#18310.....	\$259.95/ea.
All 100-Amp, V-Belt, Smooth, Chrome	#18311.....	\$195.95/ea.
All 100-Amp, 6-Groove, Smooth, Chrome	#18312.....	\$195.95/ea.
All 150-Amp, 1-V-Belt Pulley, Smooth, Polished	#14049.....	\$249.95/ea.
All 100-Amp, 2-V-Belt Pulley, Smooth, Polished	#14050.....	\$195.95/ea.
All 150-Amp, 6-Groove Pulley, Smooth, Polished.....	#14051.....	\$195.95/ea.



POWER STEERING STYLE ALTERNATORS

These replacement 85-amp alternators look just like your generator but they give you the power you need to run all those late model electrical upgrades. Your original power steering pump attaches just like it did on your generator and once installed it looks completely original. Available with or without provisions for running your original generator light.

1955-59 85-Amp, w/ GEN Light	#18666.....	\$549.95/ea.
1955-59 85-Amp, w/o GEN Light	#18667.....	\$549.95/ea.



POWERMASTER POWERGEN ALTERNATORS WITH LAMP TERMINALS

With more power and the addition of a trouble light terminal, the PowerGen is a great way to add modern charging power with vintage looks. Verify which size you need before ordering. Short versions have a 6-inch field housing and long versions have a 7.1-inch field housing. Long versions use 7-inch bracket, and short versions use 6-inch bracket.

1955-57 90-Amp, Short, Black..... #16898..... \$429.95/ea.
 1955-57 90-Amp, Short, Chrome.. #16899..... \$569.95/ea.
 1955-57 90-Amp, Long, Black #16900..... \$429.95/ea.
 1955-57 90-Amp, Long, Chrome... #16901..... \$569.95/ea.



POWERMASTER POWERGEN ALTERNATORS

Retro meets techno, generator looks with alternator reliability. PowerGen's feature 90-amps output (60 at idle) and utilize one wire hookup and are designed to use the original generator brackets. Long versions use 7-inch bracket, and short versions use 6-inch bracket.

1955-57 90 Amp, Short, Black..... #14045..... \$439.95/ea.
 1955-57 90-Amp, Long, Black #13248..... \$439.95/ea.
 1955-57 90-Amp, Long, Polished . #13249..... \$469.95/ea.
 1955-57 90-Amp, Short, Polished #14046..... \$469.95/ea.
 1955-57 90-Amp, Short, Chrome.. #14047..... \$549.95/ea.
 1955-57 90-Amp, Long, Chrome... #14048..... \$549.95/ea.



POWERMASTER ALTERNATORS

Powermaster alternators are internally regulated and can be set up for either one or three wire operation. Each alternator comes with a "Proof of Performance" assuring you that your alternator has been fully tested and quality assured. V8 alternator brackets can be found on pages 506-507.

All 100-Amp, Chrome..... #12890..... \$149.95/ea.
 All 150-Amp, Chrome #12891..... \$189.95/ea.
 All 100-Amp, Natural #13245..... \$129.95/ea.



6-CYLINDER ALTERNATOR CONVERSION BRACKET KIT

For the original 235 C.I. 6-Cyl when converting to an alternator.

1955-57 #14224..... \$63.95/kit



Photo courtesy of GERTMAN2000



BILLET SPECIALITIES

ONE-PIECE ALTERNATOR PULLEY WITH FAN

All Polished..... #17046..... \$67.95/ea.



BILLET ALTERNATOR PULLEY

All Single Groove, Polished #12463..... \$37.95/ea.



ALTERNATOR PLUGS

All CS130, w/ Lead Wire #17507..... \$27.95/ea.

All CS130D, w/ Lead Wire #17508..... \$31.95/ea.



#17506

ALTERNATOR CONVERSION PLUGS

All SI to CS Series Alternators #17505..... \$22.95/ea.

All SI to CS130D Series Alternators
..... #17506..... \$29.95/ea.



ALTERNATOR CHARGE WIRE

Recommended for high output alternators.

All 6-Gauge, 84" #13247..... \$42.95/ea.



ALTERNATOR BATTERY TERMINAL BOOT

All..... #13246..... \$6.95/ea.

Thanks for posting to Facebook!

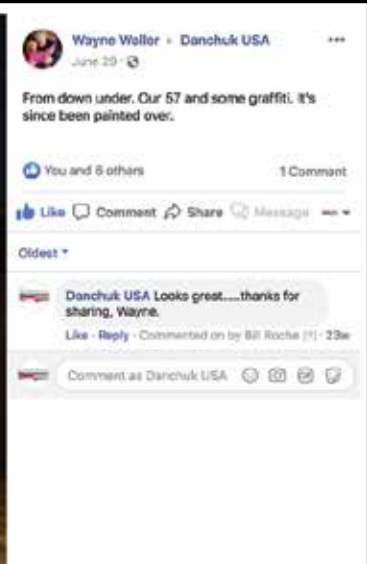



PAINLESS PERFORMANCE WIRE HARNESS KITS

The Painless 21 and 28-circuit harness is designed to custom fit your Shoebox Chevy with a factory location fuse panel, special dash and turn signal connectors. These harnesses feature color coded wires fully labeled with each circuit the entire length of the wire. Some additional parts will be required.

- 1955-57 28-Circuit #14622..... \$539.95/kit
- 1955-57 21-Circuit #14623..... \$499.95/kit

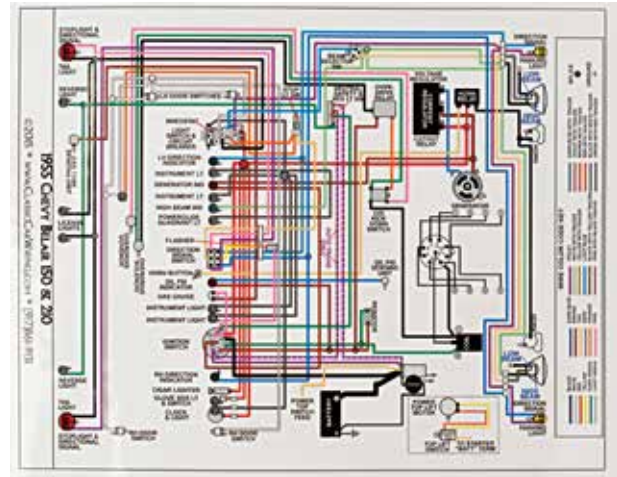
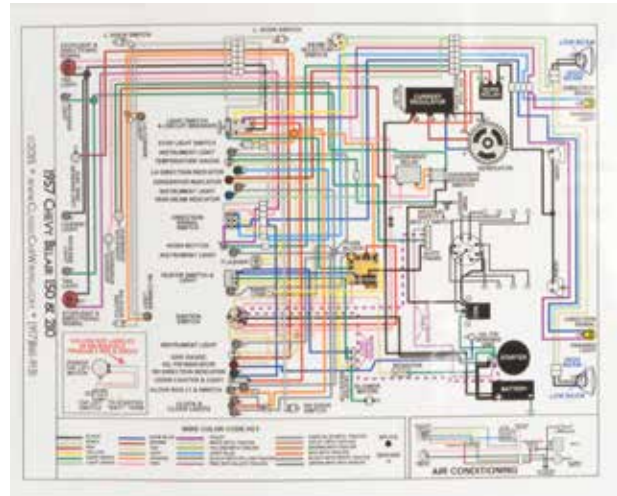

LAMINATED COLOR WIRING DIAGRAMS

Tired of those hard to read almost impossible to decipher black and white wiring diagrams copied out of 60 year old shop and repair manuals? Danchuk has the solution!

- All wire colors (including tracers) and component information is from the original factory service manuals. This means the wire colors on the diagram are the same as what was originally in your car.
- Diagram covers the complete basic car including: interior and exterior lights, engine and engine compartment, firewall, under dash, instrumentation, etc.
- All text is crystal clear and easy to read, and all colors are easy to distinguish.
- Diagrams are laminated in heavy plastic for durability and ease of use. (no more grease smudged expensive shop manuals!). Field tested and mother approved with coffee, beer, soda, all kinds of grease, dirt and paint. Sorry, battery acid likes them just as much as battery trays.

- 1955..... #18366..... \$17.95/ea.
- 1956..... #18367..... \$17.95/ea.
- 1957..... #18368..... \$17.95/ea.



PAINLESS PERFORMANCE HALOGEN HEADLIGHT HARNESS

They are made with TXL high temp wire, weather resistant 30-amp fuse, and two 40-amp weather resistant relays capable of handling up to 150 watts. Part #14610 is for use with a H-9004 and H-9007 bulbs .

All..... #14610..... \$109.95/ea.



PAINLESS PERFORMANCE CLASSIC BRAID WIRE WRAPS

The newest wire wrap by Painless Performance is "Classic Braid". Classic Braid is a tighter weave than power braid which looks very original in your classic car. It is woven from high tech materials and features a lateral split for ease of installation. Classic Braid resists cuts and abrasions and it retains it's shape up to 250 degrees. The Classic Braid chassis kit contains: 6-feet of 1-inch diameter, 10-feet of 3/4-inch diameter, 30-feet of 1/2-inch diameter, 60-feet of 1/4-inch diameter and 15-feet of 1/8-inch diameter classic braid wire wrap along with heat shrink, tie wraps and tape.

All.....	#17031	\$169.95/kit
All 1/2", 10-ft.....	#17028	\$31.95/ea.
All 3/4", 6-ft.....	#17029	\$28.95/ea.
All 1", 12-ft.....	#17030	\$45.95/ea.



PAINLESS PERFORMANCE POWER BRAID WIRE WRAPS

Power Braid protects and cleans up any harness installation with ease. Power Braids laterally split design closes around wire bundles without the need for additional taping or fasteners.

All 1/4", 20-ft.....	#14618	\$29.95/ea.
All 1/2", 10-ft.....	#14619	\$29.95/ea.
All 3/4", 6-ft.....	#14620	\$29.95/ea.
All 1-1/2", 4-ft.....	#14621	\$39.95/ea.
All 1/8", 20-ft.....	#18361	\$33.95/ea.
All 1/4", 20-ft Classic Braid.....	#18362	\$34.95/ea.

OVERDRIVE WIRE HARNESS SWITCH PLUG

This new overdrive connector plug holds the 4 wires that plug onto the kick down switch on the carburetor.



1955-68.....	#18935	\$21.95/ea.
--------------	--------	-------------

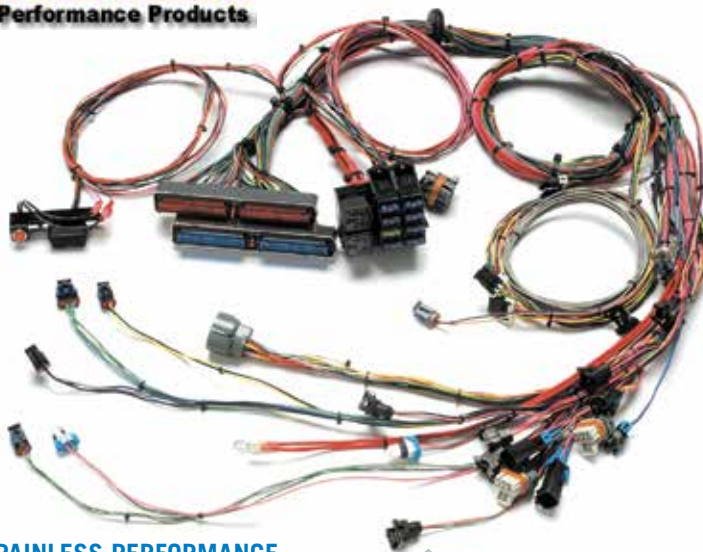

PAINLESS PERFORMANCE FUEL INJECTION WIRE HARNESSSES



Those who choose to run the factory ECM will appreciate the simplicity of a Painless fuel injection wire harness. You can try to make the stock harness work, but why complicate things? Painless has worked out all the potential problems, so all you have to do is follow the instructions and you're on your way. Every wire is labeled for ease of installation.

2003-06 4.8-6.0L.....	#17419	\$699.95/kit
1997-04 LS1, LS6.....	#17420	\$599.95/kit
2006-08 LS-2,3,7, W-4L60E/65E.....	#17421	\$699.95/kit
2007-Up Gen IV W-4L65-85E Transmission.....	#17422	\$749.95/kit



1957 GRILLE BAR WIRING CONNECTOR AND GROMMET SET 1957.....

#18274	\$17.95/set
--------	-------------

INNER FENDER TERMINAL BLOCK CLIPS

These clips hold the wire harness plastic connectors in place on each side of the radiator. Due to variances on some reproduction wire harnesses, some fitting may be required on the plastic connector.



1955-56.....	#17012	\$9.95/pr.
--------------	--------	------------



CLASSIC UPDATE COMPLETE WIRE HARNESSSES

If you are wanting to update the wiring in your 5-6-7 the Classic Update Series harness kit is the way to go. These kits have given the builder complete flexibility to use original stock switches and components as well as custom updated accessories, such as Dakota Digital, Vintage Air, and Ididit Steering Columns. Each kit comes with all the switches and sockets needed. If installing in a convertible be sure to order the convertible top harness #15064. Ignition key and tumbler not included, part #17800 on page 263.

1955-56	#11203	\$611.95/kit
1957	#11204	\$611.95/kit
1955-57 Convertible Top Harness	#15064	\$34.95/ea.



WEATHER PROOF HALOGEN HEADLIGHT HARNESS

This headlight harness gets you the maximum power from your headlights, and is recommended for any H4 or 9000 series headlight upgrade. Draws power directly from battery, through the relay.

All OE, H4	#14609	\$160.95/ea.
-------------------------	---------------------	---------------------



FAN-THOM II ELECTRIC FAN CONTROL KITS

Fan-Thom fan controls offer you clean, simple and safe fan controller for electric fans. The supplied thermostat threads into the engine or cooling system for a professional installation.

All 200°	#14615	\$58.95/kit
Note: Turns fan on at 200° & off at 185°.		
All 185°	#14616	\$53.95/kit
Note: Turns fan on at 185° & off at 170°.		

WIRING CONNECTORS FOR ELECTRIC GAUGES

Auto Meter gauge wire connectors allow you to construct your own custom gauge harnesses. They're designed for use with Auto Meter short-sweep electrical gauges—and include terminal connectors and the necessary crimp terminals for use on short-sweep electric air-core gauges.



All 3-Terminal, Short Sweep	#18091	\$17.95/ea.
All 8-Terminal, Tach/Speedo	#18092	\$17.95/ea.



WEATHERPROOF FUEL PUMP RELAY KIT

All	#14614	\$59.95/ea.
------------------	---------------------	--------------------



#12807

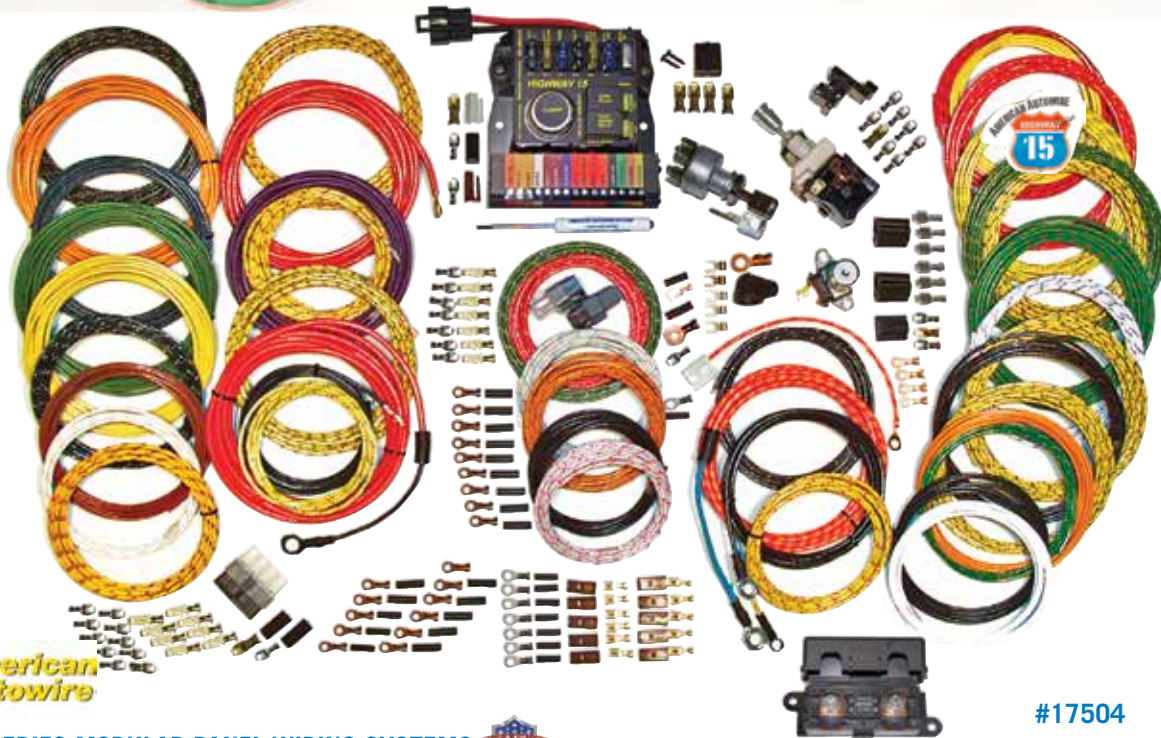

#17504



HIGHWAY SERIES MODULAR PANEL WIRING SYSTEMS

American Autowire Highway series are available in either 15 circuit or 22 circuit systems. The modular design is over engineered for street rods and custom applications. Kits feature large easy to read circuit printing on every GM color coded wire. Wiring harness kits come with headlight, ignition and dimmer switches, and can be configured for GM column mounted ignitions. Also included is a full color schematic and step-by-step instructions for trouble free installation. For a traditional 1950's look of braided and lacquer wire, be sure to order the Highway 15 Nostalgia wiring system, shown above.

All 15-Circuit, Highway 15	#12807.....	\$418.95/kit
All 15-Circuit, Highway 15 Nostalgia	#17504.....	\$1259.95/kit
All 22-Circuit, Highway 22	#12808.....	\$488.95/kit



Electrical

FACTORY FIT WIRING HARNESSSES



We are proud to offer FACTORY-FIT wire harnesses. These quality USA made wire harnesses are manufactured to original GM specifications using original GM components. Where original parts are not available, new parts have been fabricated to original specifications. With safety and longevity being an issue, the original design concepts have been improved upon to provide the highest quality harnesses available. Just as DanChuk does, FACTORY-FIT takes pride in their workmanship and places the utmost emphasis on the manufacturing of quality products. **Made in the USA.**



WIRING HARNESSSES

1955-57 Lighter Fuse	#1199	\$10.95/ea.	1956 V8 Overdrive.....	#440	\$95.95/ea.
1955 6-Cyl. Standard Starter-Ignition	#437	\$69.95/ea.	1956 6-Cyl. Overdrive.....	#1584	\$93.95/ea.
1955 6-Cyl. Automatic Starter-Ignition.....	#427	\$79.95/ea.	1956 4-Door Sedan Taillight	#448	\$169.95/ea.
1955 V8 Standard Starter-Ignition	#423	\$69.95/ea.	1956 4-Door Hardtop Taillight	#448A	\$149.95/ea.
1955 V8 Automatic Starter-Ignition.....	#404	\$69.95/ea.	1956 2-Door Hardtop & Sedan Taillight	#433	\$139.95/pr.
1955 Heater &/or A/C Control Panel Light	#1573	\$8.95/ea.	1956-57 4-Door Wagon Fuel Tank Ext. Wire.....	#1572	\$8.95/ea.
1955 Fuse Panel to Heater Switch.....	#1574	\$8.95/ea.	1957 2-Door Wagon Taillight	#453B	\$169.95/ea.
1955 Fuse Panel to Heater Blower Switch.....	#1575	\$8.95/ea.	1957 4-Door Wagon Taillight	#456B	\$124.95/ea.
1955 Fuse Panel	#426	\$18.95/ea.	1957 Nomad Taillight	#450B	\$169.95/ea.
1955 Under Dash w/ Internal Alternator			1957 Grille Bar.....	#424	\$39.95/ea.
(Includes Headlight Generator)	#2765	\$204.95/ea.	1957 Headlight Socket	#443	\$18.95/pr.
1955 Under Dash (Includes Headlight Generator)	#415	\$194.95/ea.	1957 Headlight Socket	#19381	\$36.95/pr.
1955 Clock Socket & Pigtails	#431	\$19.95/ea.	1957 Back-Up Lights	#406	\$24.95/ea.
1955 Heater Fan Motor	#418	\$8.95/ea.	1957 Courtesy Lamp, Underdash	#459A	\$38.95/ea.
1955 Alternator Conversion w/ External Regulator ...	#408	\$59.95/ea.	1957 Overdrive.....	#436	\$93.95/ea.
1955 Starter-Ign. V8 Auto w/H.E.I. Distributor.....	#12359	\$79.95/ea.	1957 Heater Fan Motor	#425	\$8.95/ea.
1955 Starter-Ign. V8 Standard w/H.E.I. Distributor...	#12360	\$69.95/ea.	1957 6-Cyl. Headlight Generator	#441	\$104.95/ea.
1955 V8 Overdrive.....	#434	\$93.95/ea.	1957 V8 Headlight Generator.....	#441A	\$94.95/ea.
1955 6-Cyl. Overdrive.....	#1583	\$93.95/ea.	1957 Alternator Conversion w/ Ext. Regulator.....	#411	\$59.95/ea.
1955 2-Door Sedan Taillight	#442	\$139.95/ea.	1957 Alternator Conversion w/ Int. Regulator	#410	\$54.95/ea.
1955 4-Door Sedan Taillight	#447	\$149.95/ea.	1957 Starter-Ign. V8 Auto w/H.E.I. Distributor.....	#12363	\$69.95/ea.
1955 2-Door Hardtop Taillight.....	#419	\$139.95/ea.	1957 Starter-Ign. V8 Standard w/H.E.I. Distributor ...	#12364	\$79.95/ea.
1955-56 Parklight.....	#420	\$34.95/pr.	1955-57 Trunk Light Assembly	#12367	\$34.95/ea.
1955-57 Parklight for Press-In Socket.....	#420A	\$59.95/pr.	1957 V8 Dual 4BC Standard Starter-Ignition.....	#1588	\$79.95/ea.
1955-56 Headlight	#402	\$39.95/pr.	1957 V8 Dual 4BC Automatic Starter-Ignition.....	#1586	\$79.95/ea.
1955 4-Door Wagon Taillight	#456	\$169.95/ea.	1957 V8 F.I. Standard Starter-Ignition	#1589	\$79.95/ea.
1955 2-Door Wagon Taillight	#453	\$159.95/ea.	1957 V8 F.I. Automatic Starter-Ignition	#1587	\$84.95/ea.
1955 Nomad Taillight	#450	\$169.95/ea.	1957 6-Cyl. Standard Starter-Ignition	#438	\$69.95/ea.
1955 Convertible Taillight.....	#444	\$189.95/ea.	1957 6-Cyl. Automatic Starter-Ignition.....	#416	\$79.95/ea.
1956 2-Door Wagon Taillight	#453A	\$169.95/ea.	1957 V8 Standard Starter-Ignition	#422	\$69.95/ea.
1956 4-Door Wagon Taillight	#456A	\$169.95/ea.	1957 V8 Automatic Starter-Ignition.....	#405	\$69.95/ea.
1956 Nomad Taillight	#450A	\$169.95/ea.	1957 Heater Control Panel Light.....	#1577	\$8.95/ea.
1956 Convertible Taillight.....	#444A	\$189.95/ea.	1957 Under Dash.....	#414	\$189.95/ea.
1955-56 Back Up Lights w/ Conversion Plates	#401	\$39.95/pr.	1957 Clock Socket & Pigtails	#430	\$19.95 /ea.
1955-56 Courtesy Lamp, Underdash	#459	\$38.95/ea.	1957 6-Cyl. Overdrive.....	#1585	\$93.95/ea.
1955-56 Alternator Conversion w/ Int. Regulator....	#403	\$54.95/ea.	1957 6-Cyl. Conv. Solenoid-to-Pwr Top Connector		
1955-56 6-Cyl. Solenoid-to-Pwr Top Conn.	#1578	\$11.95/ea.	#1580	\$13.95/ea.
1955-56 V8 Solenoid-to-Pwr Top Connector	#1579	\$11.95/ea.	1957 V8 Conv Solenoid-to-Pwr Top Connector	#1581	\$11.95/ea.
1955-56 Taillight Harness Pigtails	#12246	\$38.95/ea.	1957 Convertible Taillight.....	#446	\$179.95/ea.
1955-56 Taillight Harness Pigtail Grommets	#12244	\$27.95/ea.	1957 4-Door Hardtop Taillight	#449	\$169.95/ea.
1955-57 Dakota Digital Gauge Wiring Kit.....	#12368	\$49.95/kit	1957 4-Door Sedan Taillight	#449A	\$169.95/ea.
1956 6-Cyl. Standard Starter-Ignition	#439	\$69.95/ea.	1957 2-Door Hardtop Taillight	#413	\$139.95/ea.
1956 6-Cyl. Automatic Starter-Ignition.....	#428	\$84.95/ea.	1957 2-Door Sedan Taillight	#413A	\$139.95/ea.
1956 V8 Standard Starter-Ignition	#421	\$69.95/ea.	1957 Taillight Harness Pigtails	#12247	\$38.95/pr.
1956 V8 Automatic Starter-Ignition.....	#407	\$69.95/ea.	1957 Taillight Harness Pigtail Grommets	#12245	\$27.95/pr.
1956 Under Dash.....	#429	\$189.95/ea.	1957 Headlight Gen. Harness w/ Internal Alt.	#2767	\$114.95/ea.
1956 Clock Socket & Pigtails	#432	\$19.95/ea.	1955-56 6-Cyl. Solenoid Rear Body Power Top Connector Lead		
1956 Automatic Column Shift Indicator Light.....	#1576	\$8.95/ea.	#13864	\$9.95/ea.
1956 Headlight Generator	#417	\$94.95/ea.	1955-56 Solenoid To Power Access. Circuit Breaker, 6-Cyl.		
1956 Headlight Gen. Harness w/ Int. Altern.....	#2766	\$114.95/ea.	#13866	\$9.95/ea.
1956 Alternator Conversion w/ Ext. Regulator.....	#412	\$59.95/ea.	1955-56 Solenoid to Power Access. Circuit Breaker, V8		
1956 Starter-Ign. V8 Auto w/H.E.I. Distributor.....	#12361	\$79.95/ea.	#13867	\$12.95/ea.
1956 Starter-Ign. V8 Standard w/H.E.I. Distributor ...	#12362	\$79.95/ea.	1957 Solenoid to Rear Body Connector, 6-Cyl.	#13868	\$11.95/ea.

 WARNING! Products on these pages may contain chemicals known to the State Of California to cause cancer and/or birth defects or reproductive harm. www.p65warnings.ca.gov



CRUISE CONTROL KITS

Whether you have a cable driven speedo or updated to a new electronic speedo you can add the convenience of cruise control to your classic Chevy. Kits come with everything to install including a controller that replaces the turn signal arm on factory original, Ididit and Flaming River Columns.

- All for Cable Driven Speedometers..... #15124..... \$299.95/kit
- All for Electronic Speedometers..... #15125..... \$268.95/kit



STAINLESS CRUISE CONTROL CABLES

An excellent upgrade to our cruise control kits #15124-25.

- All Cut to Fit #15143..... \$105.95/ea.
- All Tune Port Engines #15144..... \$105.95/ea.



DASH MOUNTED CRUISE CONTROL SWITCH

For those who prefer to mount their cruise control controller on the dash or anywhere else.

- All..... #15126..... \$61.95/ea.



Photo courtesy of GERTMAN2000



CRUISE CONTROL HANDLE COVERS

Dress up your column mounted controller with one of these handle covers. Fits cruise control kits, #15124 or #15125 above.

- All Polished Aluminum #15127..... \$46.95/ea.
- All Brushed Aluminum #15128..... \$46.95/ea.



IDIDIT TOUCH-N-GO KEYLESS IGNITION SYSTEM

Get the most advanced keyless ignition technology at the tip of your finger, with the Touch-N-Go Start keyless ignition system from Ididit. This is the industries FIRST touch sensitive start system and features a 22mm aluminum button with multi-color LED lights that always let you know what mode it's in. There are no moving components to wear out, ensuring years of outstanding performance. You'll never have to use your keys again! Just stick your programmable key fob in your pocket or wallet and the system will sense your approach, having the capability of automatically unlocking your door as you get close and locks as you leave (the system only responds when the key fob is in range). For added safety, this system can also be programed to turn on your dome lights as you approach.

All..... #17032..... \$749.95/kit



AUTO METER GPS SPEEDOMETER INTERFACE MODULE

This Auto Meter universal GPS interface module turns any electronic speedo into a GPS speedo with the push of a button. The units are plug and play for all Auto Meter speedos and they will also work with virtually any electronic speedo on the market with an on-button 10 second calibration. The paintable magnetic micro antenna is fully sealed to keep out water and dust. 10 Hz sampling rate.

All..... #17014..... \$249.95/ea.



CLASSIC INSTRUMENTS GPS SKYDRIVE ANTENNA, SPEEDOMETER SENDER

Calibrate your Classic Instruments speedometer in less than a minute and you don't even have to leave your driveway! Sky Drive is the world's most accurate electronic speedometer sending unit. No need for ECU convertors or pulse signal generators screwed onto your transmission. The new Sky Drive uses GPS Satellite signals to operate your electronic speedometer. It updates 10 times per second and with one push of a button it's ready to go. SkyDrive! The World's Most Accurate Speedo Sender.

All..... #16989..... \$299.95/ea.

DAKOTA DIGITAL SPEEDOMETER GPS INTERFACE

The Dakota Digital speedometer GPS interface modules are specifically made for the custom automotive market. Their highly advanced electronic and software design allows them to work unlike anything else, with accelerometers and predictive software to compensate for the times when GPS inherently struggles: overpasses, mountains, tunnels, heavy tree cover, large buildings, passing large vehicles, etc. Their unique electronic architecture provides for negligible current usage when off, and yet they offer lightning fast start-up and signal acquisition. Updating the speed information 10 times per second provides tremendous accuracy, while their integrated omnidirectional antenna provides for installation flexibility and simplicity.

The Dakota Digital speedometer GPS interface modules do such a tremendous job of rendering the correct speed information, they can be used to feed an aftermarket cruise control system. They can be used in conjunction with a Dakota Digital VFD3 or VHX instrument system and the modules are also fully compatible with other electronic speedometers on the market.

All..... #18675..... \$199.95/ea.





#14265



#14266

**PUSH BUTTON AM/FM RADIOS
- NOW WITH BLUETOOTH 3.0**

These reproduction radios are the closest things to the originals in appearance, but they have many of the updated features you need for a better sound system. All radios fit just like the originals and use factory style antenna. Now with built-in

Bluetooth 3.0 that lets you make calls and stream music handsfree. All radios feature: AM/FM digital tuner, AM dial is in foreground FM is in background, 10 Presets (5AM, 5FM), 4 x 45 watts RMS out, CD or satellite radio inputs, correct knobs and pushbuttons. Knobs control: volume, bass, treble, balance, fader and tuning.

1955 180 Watts	#14265	\$632.95/ea.
1956 180 Watts	#14266	\$632.95/ea.



RADIO KNOBS

Works with stock radios only.

1955	#11255	\$11.95/ea.
1956	#11256	\$10.95/ea.
1957	#887	\$39.95/set

**RADIO TONE
CONTROL KNOBS**

Includes one tone control knob and one dummy. Used on all standard and pushbutton radios.



1955-56	#989	\$7.95/pr.
----------------------	-------------------	-------------------

1957 RADIO TONE CONTROL KNOB

Flawless injected knobs just like the originals.



1957	#990	\$4.95/ea.
-------------------	-------------------	-------------------



1957 RADIO PUSH BUTTONS

After years of use it's time to replace those cracked and faded pushbuttons. Set of five.

1957	#946	\$19.95/set
-------------------	-------------------	--------------------

RADIO VIBRATOR TUBE

This solid state radio vibrator tube will replace the one in your original radio. Type 2215-N. **Made in the USA.**



1955-57	#859	\$38.95/ea.
----------------------	-------------------	--------------------

RADIO TUBE

This radio tube is designated OZ4/OZ4A. It will replace the one in your original radio. **Made in the USA.**



1955-57	#985	\$13.95/ea.
----------------------	-------------------	--------------------

RADIO SPEAKER BOOT

This boot transmits the sound from your speaker through the dashboard. Works with original speaker brace.



1955-56	#858	\$24.95/ea.
----------------------	-------------------	--------------------

RADIO GROUND STRAPS

This kit contains three ground straps that were originally used with original AM radios, one for under the dash, one for under the hood from the firewall to the engine and one for under the car from the transmission to the floor pan inspection plate. Use for V8 or 6-cyl applications.



1955-57	#931	\$21.95/set
----------------------	-------------------	--------------------



#17157



#17158

AM/FM WONDERBAR RADIOS - NOW WITH BLUETOOTH 3.0

These reproduction radios are the closest things to the originals in appearance, but they have a lot of the updated features you need for a better sound system. All radios fit just like the originals and use factory style antenna, the Wonderbar duplicates the action of the original as it seeks up, then returns to the bottom and starts over. Now with built-in Bluetooth 3.0 lets you make calls and stream music handsfree. All radios feature: AM/FM digital tuner, AM dial is in foreground FM is in background, 10 Presets (5AM, 5FM), 4X45 watts RMS out, CD or satellite radio inputs (2 RCA rear jacks), correct knobs and pushbuttons. Knobs control: volume, bass, treble, balance, fader and tuning.

1955 180 Watts (Shown)	#17157	\$748.95/ea.
1956 180 Watts (Shown)	#17158	\$809.95/ea.
1957 180 Watts	#14267	\$749.95/ea.

RADIO SPEAKERS

For those original Chevrolet radios there is only one 4 ohm speaker to consider: ours. This reproduction



is accurate all the way down to the audio response specifications. It not only looks like the original, it sounds like the original, too. This speaker was designed for mono radios only; for stereos see parts #10847, #10848 and #10849.

1955-57 Standard Radio w/o Transformer	#018	\$48.95/ea.
1957, 58-62 Vette Pushbutton Radio w/ Transformer (Shown)	#017	\$55.95/ea.



STEREO SPEAKERS

All 6" x 9", 200 Watts, 3-Way..... #12170.....\$99.95/pr.

KENWOOD DUAL FRONT SPEAKER

Kenwood quality upgrade replacement for your original front in-dash speaker. This great quality speaker can handle up to 80 watts and is built and designed to fit directly in the stock location.



1955-57 #10848..... \$76.95/ea.

DUAL FRONT SPEAKER

This speaker can handle up to 50 watts and is built and designed to fit directly under the dash.



1955-57 #10849..... \$31.95/ea.

DUAL VOICE COIL SPEAKER

Get the best quality sound possible from your original dash speaker location. These speakers have up to 70% more cone area than the conventional dual speaker setup. This will give you improved bass response and power handling. Dual tweeter and both channels hook up to one speaker.

1955-57 120 Watts #10847..... \$59.95/ea.



STEREO AMPLIFIER

200 watts per channel x 2. All..... #11180\$149.95/ea.

SPEAKER BRACE

If your 1955-56 doesn't have the original bracket for the dash speaker this unit will enable you to install a new speaker.

1955-56 #10850.\$29.95/ea.



#10174

SPEAKERS

KICK PANEL SPEAKERS

Want more sound without cutting or drilling? These "kicks" sound great, enhance interior appearance and affords a "no modification" fit. Made of black ABS plastic and can be painted to match your interior.

- 1955-56 100 Watt..... #10172.....\$149.95/pr.
- 1957 100 Watt #10174.....\$149.95/pr.
- 1955-56 Pioneer, 120 Watt #10175.....\$199.95/pr.
- 1957 Pioneer, 120 Watt..... #10177.....\$199.95/pr.



BACKSEAT DRIVER SPEAKER ASSEMBLY

1955-57 400 Watt Amp, 8" Woofers

..... #13408..... \$265.95/set



CUSTOM AUTOSOUND UNDERCOVER STEALTH SPEAKERS

Enclosure is 8-inch x 11-inch and only 2-7/8-inch high and features a 5-1/2-inch woofer and two tweeters in each enclosure.

All 120 Watts #12143.....\$139.95/pr.



#13281

#13280

KICK PANELS WITHOUT SPEAKERS

Use these kick panels with speakers 6" in diameter.

- 1955-56 #13280.....\$99.95/pr.
- 1957..... #13281.....\$99.95/pr.



UNDERCOVER 2 SPEAKERS

Want a little more from your hidden speaker system? This is it! The UNDERCOVERII with an 8-inch woofer and 2 Piezo tweeters in each box. This system can be mounted in many of the same locations as the regular UNDERCOVER. With the 8-inch woofer in UNDERCOVERII you get a much fuller deeper sound. 200 watt capacity. Sold as pair. Measure 11-inch W x 12.5-inch D x 3-inch H

All 250 Watt..... #16357.....\$165.95/pr.



REAR SPEAKER GRILLES

- 1955-57 Black..... #17601.....\$16.95/ea.
- 1955-57 Chrome #19040.....\$25.95/ea.

CHECK PAGE 186 FOR TMI CUSTOM UPHOLSTERY KICK PANEL SPEAKERS AVAILABLE VIA SPECIAL ORDER.



CUSTOM AUTOSOUND AMPLIFIED SPEAKER - SYSTEM 1

Flat active aluminum subwoofer enclosure with 8" woofer plus 2-channel amplifier. Two 3" mid-tweeter satellite speakers in die cast metal housings. Amplifier installation kit included. Amplifier power: 150 watt subwoofer / 2x50 watt mid / tweeter.

All w/ Satellite Speakers..... #17353..... \$299.95/ea.

SECRETAUDIO

CUSTOM AUTOSOUND SECRETAUDIO STEREO SYSTEMS

With Stealth Sound Technology the SST-V is equipped with bluetooth for streaming your favorite tunes as well as a hands free option for your cell phones. The SST-V is a 200 watt AM/FM radio with USB MP3/WMA flash drive, iPod control, CD control and satellite-ready via bluetooth. The SST-V features "RF" (radio frequency) remote control making it ideal for your classic. The SST-V hideaway radio is designed to provide your classic car exceptional audio quality leaving the dash and original radio visible in the dash. The SST-V receiver/ amplifier unit is usually hidden underneath the driver's seat or behind the dashboard and integrates with the vehicle's speaker system. If your speakers are for a mono radio they should be replaced with dual voice coil speakers, Danchuk parts #10847, #10848, or #10849.



1955-72 SST..... #10845..... \$359.95/set

Custom Autosound kits modify each radio to fit specific vehicles so the radio fits your dash right out of the box. No kits, bezels or modifying to get the look and fit you want for your vehicle.



CUSTOM AUTOSOUND USA-230 STEREO

This new model radio has the same cosmetics as the USA-630. If you don't need the USB/MP3 or CD changer control, then this is the model for you. Radio has no cassette but comes with auxiliary audio input. If you have a portable MP3 player or Satellite radio just plug it into the AUX input and listen to it through this radio.

Features Include:

AM/FM stereo, 200 watts (4x50), auxiliary input (RCA rear), RCA to 1/8" pin jack included, digital clock, electronic tuner, 30 pre-sets (4AM & 12FM), 4-channel RCA pre-outs, 4-way fader, power antenna lead

- 1955 Chrome, No Cassette..... #15471..... \$199.95/ea.
- 1956 Chrome, No Cassette..... #15472..... \$199.95/ea.
- 1957 Chrome, No Cassette..... #15473..... \$199.95/ea.



CUSTOM AUTOSOUND USA-4DIN STEREO

If your car's dash has been modified to fit a more modern radio, but the radio never quite looked right because it was too modern, or you want to do a custom install in the dash or console and want a CD player that looks the part, your radio is finally here. The USA-4DIN is the first in-dash CD/MP3 player that looks like it belongs in your classic and features a fold down fully detachable chrome front panel and front USB port.

Features Include:

AM/FM-CD MP3 player, 24 presets (18FM-6AM), 160 watts (4X40), 1 pair of RCA pre-outs, Separate Bass and Treble, Clock, Front Aux. input, front USB port. Fits in standard DIN radio opening (approx) 7.2" X 2.11".

- 1955-57 AM/FM, CD..... #15636..... \$184.95/ea.

IF YOU OWN A CLASSIC, OTHER THAN A 55-56-57, ASK OUR CUSTOMER SERVICE REPS ABOUT CUSTOM AUTOSOUND'S FULL LINE OF AUDIO SYSTEMS AVAILABLE THROUGH DANCHUK.



#18019



#18018

CUSTOM AUTOSOUND SLIDEBAR RADIO

The Slidebar Radio is Custom Autosound's latest innovation in the quest for a perfect classic car radio. Just slide the "slidebar" to the right and the analog AM radio display drops away to reveal a full featured digital display. With the large OEM style push-buttons you get a perfect look in a classic dash. A radio that looks right and sounds great in your classic, it has the latest modern features that include an iPod dock.

Features Include:

- AM/FM RDS Tuner w/ 25 Pre-sets • RDS Tuner show Station/Song/Artist on LCD Display • 300 Watts Peak • 7 LCD Color Choices • LCD Dimmer Control • Bluetooth Option Available • iPod Dock and Control • USB Port for Flash Drive MP3/WMA Playback • Direct 6-Disc CD Changer Control • Alpha-Numeric Display for MP3/WMA/iPod Files • Electronic Tuning/Volume Control w/ Last Volume • Bass/Mid/Treble Tone Control • Loudness Compensation • DSP EQ • Front/Rear Fader • Left/Right Balance • Digital Clock • 2-Channel RCA Auxiliary Input for Satellite • 4-Channel RCA Pre-Outs • Subwoofer Line Out w/ Level & Cross Over Adjustments • Power Antenna Lead

- 1955-56 #18018..... \$299.95/ea.
- 1957..... #18019..... \$299.95/ea.



CUSTOM AUTOSOUND BLUETOOTH INTERFACE KIT

Custom Autosounds lets you add BlueTooth capability to their USA-630, Secret Audio and Slidebar Radios. Also listen to music stored on your A2DP enabled bluetooth device. If you have a CD changer or CD1 single player you can still use it with the adapter plugged in (there is a CD changer port on the control box of the Bluetooth kit). Main control box has a 1.5 foot cord that goes to radio CD port, 6.5 foot cord to answer button and 3.5 foot cord from answer button to microphone.

- All..... #18409..... \$109.95/kit



CUSTOM AUTOSOUND CONOURS SERIES USA-630 STEREO

This radio has large OEM style push-buttons that give a perfect look in a classic dash. Although it looks classic it has the latest modern features. USB input on the back of the radio allows you to plug in a USB flash drive for playback of MP3/WMA song files. New iPod interface with 3.5 foot docking cable. The new alpha numeric display shows the song/artist/album (id3) titles during playback of MP3/WMA and iPod files. Navigation for the iPod includes artist/song/album/playlist all from the buttons on the radio. With 300 watts the radio should have all the power you may need. The back of the radio also has auxiliary audio input for satellite radio or any portable player you may wish to use.

Features Include:

- AM-FM Stereo • RDS tuner shows station / song / artist on LCD display • 300 Watts (75w x 4) • USB Port for Flash Memory MP3/WMA Playback • iPod doc and control (Control your iPod from the buttons on the radio) • Direct 6 CD Changer Control • Negative LCD Display (Black background w/ white letters / numbers) • Alpha Numeric id3 Display for MP3/WMA files • Electronic Tuning and Volume Control • Loudness Compensation • Digital EQ • 4-Way Fader • Left Right Balance • Digital Clock • 2-Channel RCA Auxiliary Input for Satellite/Phone • 12 Pre-sets (12FM-4AM) • 4 Channel RCA Pre-outs • Separate Bass and Treble • USA/Euro Tuner • Power Antenna Lead

1955.....	#15230.....	\$259.95/ea.
1956.....	#15231.....	\$259.95/ea.
1957.....	#15232.....	\$259.95/ea.



CUSTOM AUTOSOUND CD/DVD PLAYER

This new slim sized half DIN CD/DVD player can be controlled by Custom Autosound's USA-630, USA-740, Slidebar or Secret Audio.

Features Include:

- Plays CD/CD-R/CD-RW/DVD audio/WMA/MP3, Small enough to hide under the seat or in glove box, ESP Electronic Shock Protection, Repeat/ Program/Random/Intro Function, Multi-Angle Playback, Last Position Memory, 9' Cable for connection to CAM head unit.

Dimensions: 7" wide x 1" high x 6-3/4 deep

All 1/2-DIN	#18525.....	\$179.95/ea.
-------------------	-------------	--------------



**CUSTOM AUTOSOUND USA-740 STEREO
- NOW WITH BLUETOOTH 3.0**

Introducing Custom Autosound's latest, most advanced, and featured packed Stereo to date. This is truly one of their best radios to emulate the factory original radio with its chrome face, pushbuttons, and replica AM dial that all pay tribute to the style of the 50's. The classic good looks are only the beginning. With 300 Watts, 25 Presets (15FM/10AM) and full audio controls with DSP EQ and separate Bass/Mid/Treble controls you can tailor the sound to your liking and with 4 RCA pre-out plus subwoofer line-out you can add even more power easily. The USA-740 introduces Bluetooth technology that allows you to place and answer calls and stream your favorite music and programs from you personal device. You also get selectable and dimmable LCD colors of white, red, blue, cyan, green, yellow or pink to suit your tastes or mood. Featuring a rear mounded USB (w-Extension) Front and rear AUX inputs, RCA inputs for Satellite radio as well as CD/DVD player control for an add-on player (Part #18525) the possibilities are endless.

Features Include:

- AM/FM RDS Tuner w/ 25 Pre-Sets (15FM/10AM) • RDS Tuner Shows Station/Song/Artist on LCD Display • 300 Watts Peak 2-Ohm Stable • 7 LCD Color Choices White/Red/Blue/Cyan/Green/Yellow/Pink • LCD Dimmer Control • Clock or Function Display Priority (switchable) • Bluetooth and Remote Microphone Included • USB Port for Flash Drive MP3/WMA/FLAC/WAV Playback • Direct CD-I Control • Aux-In Front and Rear • Alpha Numeric Display for MP3/WMA/FLAC/WAV • Electronic Tuning • Volume Control w/ Last Volume Memory • Bass/Mid/Treble/Tone Control • Loudness Compensation for Low Volume Listening • DSP EQ • Front / Rear Fader • Left / Right Balance • Digital Clock • 2 Channel RCA Auxiliary Input for Satellite • Hi-Volt 4 Channel RCA Pre-outs • Hi-Volt Subwoofer Line Out w/ Level X-Over Adjustments • USA/EUR/JAP/RUS Tuner Capability (USA Default) • Auto Store - Fill Presets w/ Strongest Stations • Power Antenna Lead

1955.....	#18518.....	\$349.95/ea.
1956.....	#18519.....	\$349.95/ea.
1957.....	#18520.....	\$349.95/ea.



#789

#788

ANTENNA

ANTENNA ASSEMBLIES

The antenna is a high-wear item that needs periodic replacement. We've duplicated the 1955 with its unique teardrop top. The 1956-57 is correctly done with the round top. Assemblies come complete with base, nut, gasket, template, bracket, and instructions.

1955.....	#788.....	\$78.95/set
1956-57 (Shown)	#789.....	\$78.95/set



1957 REAR MANUAL DUMMY ANTENNA

If one looks cool, two look even better. When installed with the rear manual antenna, part #1177, this antenna completes the symmetrical, full-dress look. Although it is inoperable, it still makes a high-style impression. Don't tell anyone it's a dummy; you're the only one who will know!

1957 Passenger	#1176.....	\$169.95/ea.
----------------------	------------	--------------

CUSTOM AUTOSOUND HIDDEN ANTENNA

For the best AM/FM reception nothing works better than a 31-inch vertically mounted antenna mast. Mounts on the inside top of windshield for best performance. Not recommended for underdash mounting.



1955-57	#12087	\$34.95/ea.
---------------	--------------	-------------



1957 REAR MANUAL ANTENNA WITH CABLE

Another high-style option was this operable, rear mounted antenna. It angles back sharply, giving your car a faster, sexier look.

1957 Driver.....	#1177.....	\$169.95/ea.
------------------	------------	--------------

ANTENNA BASE

For those whose antenna bases are pitted or have lost their chrome we offer this original design Danchuk part. For front fender mounting antennas. Includes rubber gasket. **Made in the USA.**



1955-57	#302.....	\$24.95/ea.
---------------	-----------	-------------



1957 ELECTRIC REAR ANTENNA

The electric antenna was a true high-tech option in 1957, and it's still a favorite today. Kit includes coaxial cable, a brilliant chrome antenna base, mounting hardware, and antenna.

1957 Passenger	#1858.....	\$474.95/ea.
----------------------	------------	--------------

ANTENNA NUT

Time will oxidize and crack those original plastic antenna nuts. This easily replaced reproduction is another detail item that won't go unnoticed.



1955-57	#302A.....	\$6.95/ea.
---------------	------------	------------

1957 CHROME REAR ANTENNA BASES

Reproduction of the rear antenna base for original and re-production rear antennas.



1957 Driver.....	#16573.....	\$39.95/ea.
1957 Passenger	#16574.....	\$39.95/ea.