

7. Fuel & Exhaust

SECTION AT A GLANCE:

Gas Tanks	304
Gas Tank Related.....	307
Sending Units	310
Gas Lines.....	312
Fuel Pumps	313
Fuel Filter.....	314
Carburetor Related.....	315
Throttle Related	318
Intake Related.....	322
Linkage	324
Air Cleaners	326
Batwing Cleaners.....	328
Aeromotive.....	329
Intake Manifolds.....	334
Manifold & Carb Kits.....	336
Carburetors	338
Cylinder Heads.....	341
Edelbrock	342
Fuel Injection.....	346
Exhaust Systems	349, 353
Headers.....	350
Exhaust Manifold.....	354
Muffler & Tailpipe Hangers	357
Insulation	360



#2100



#16991



#10853

ORIGINAL DESIGN GAS TANKS O/S

Over 60 years of dirt, rust, and sludge are sitting at the bottom of that old gas tank. Running your tank dry could put that filth right where it hurts: in your engine. While cleaning the tank will solve the immediate problem, the real solution is these original design gas tanks. These tanks have all the correct details, including the threaded sending unit mount and mounting strap depressions.

1955-56 exc. Nomad, Wagon & Sedan Delivery, 16-Gallon, Best	#2099.....	\$239.95/ea.
1955-56 exc. Nomad, Wagon & Sedan Delivery, 16-Gallon, Good	#16991.....	\$199.95/ea.
1957 exc. Nomad, Wagon & Sedan Delivery, 16-Gallon, Best.....	#2100.....	\$239.95/ea.
1957 exc. Nomad, Wagon & Sedan Delivery, 16-Gallon, Good.....	#16992.....	\$199.95/ea.
1955-56 Wagon exc. 9-Passenger Wagon, 17-Gallon.....	#10853.....	\$249.95/ea.
1957 Wagon exc. 9-Passenger Wagon, 17-Gallon.....	#10854.....	\$249.95/ea.

STAINLESS STEEL GAS TANKS O/S

The quality construction of these 18-gallon capacity gas tanks is without equal. Fits all models except the Nomad, wagon and sedan delivery. Part #895A and #896A come with pre-installed TPI system compatible fuel pumps. TPI pump output is 45-55 PSI. Mounting straps are included, but you'll need to order a set of mounting bolts, part #1215, shown on page 307. Fuel sender for 0-30 OHM gauges. Now available for the LS engines. LS fuel pump output is 60-65 PSI at 55 gallons per hour.



#896

1955-56 exc. Nomad, Wagon & Sedan Delivery	#895.....	\$859.95/ea.
1955-56 exc. Nomad, Wagon & Sedan Deliveryw/ TPI Unit	#895A.....	\$1179.95/ea.
1957 exc. Nomad, Wagon & Sedan Delivery (Shown)	#896.....	\$859.95/ea.
1957 exc. Nomad, Wagon & Sedan Delivery w/ TPI Unit	#896A.....	\$1179.95/ea.



HIGH CAPACITY GAS TANKS O/S

- | | | | | | |
|-----------------------------------|-------------|--------------|--------------------------------|-------------|--------------|
| 1955-57 25-Gallon, Aluminum | #19442..... | \$499.95/ea. | 1955-57 25-Gallon, Black | #19444..... | \$699.95/ea. |
| 1955-57 29-Gallon, Aluminum | #19443..... | \$499.95/ea. | 1955-57 29-Gallon, Black | #19445..... | \$699.95/ea. |



#19447

COMPLETE EFI GAS INSTALL KITS

- | | | |
|-------------------------------|-------------|--------------|
| 1955-57 255 LPH..... | #19446..... | \$329.95/kit |
| 1955-57 340 LPH (Shown) | #19447..... | \$399.95/kit |

OE STYLE PERFORMANCE FUEL INJECTION GAS TANKS O/S

Factory style fuel injection gas tanks feature a factory spec sending unit and internal fuel pump that is rated at 85-115 PSI at 50-60 gallons per hour. Fuel pressure regulator required, but sold separately on page 344.

- | | | |
|----------------------------------|--------------|--------------|
| 1955-56 exc. Wagon, 16-Gallon .. | #14947 | \$699.95/ea. |
| 1957 exc. Wagon, 16-Gallon..... | #14948..... | \$699.95/ea. |



#14948

REPLACEMENT FUEL INJECTION FUEL MODULE

This is a complete replacement fuel module for the Danchuk #14947 and #14948 OE style performance fuel injection gas tanks. You get the hanger and sender assemblies along with the strainer, float and wiring harness. You will need a fuel pressure regulator to run this pump, sold separately.

- | | | |
|---------------|--------------|--------------|
| 1955-57 | #18771 | \$249.95/ea. |
|---------------|--------------|--------------|

REPLACEMENT FUEL INJECTION FUEL PUMP

- | | |
|-----------------------------|-------------------------|
| For tanks #14947 or #14948. | |
| All..... | #17834..... \$49.95/ea. |



STAINLESS STEEL GAS TANKS WITH LS PUMP UNIT INSTALLED O/S

- 1955-56 w/ Straps..... #14253... \$1249.95/ea.
- 1957 w/ Straps..... #14254... \$1295.95/ea.

AEROMOTIVE GEN II STEALTH GAS TANKS O/S

The Aeromotive Gen II Stealth tanks are the next generation of stealth tanks. They feature outlet and return ports along with electrical terminals positioned in the OEM location which allows for a flush installation to the vehicle floor and will not require strap modification or spacers. Just plug n' play.



- Note: will not work on Nomads or wagons.**
- 1955-57 200LPH..... #19157..... \$498.95/ea.
 - 1955-57 340LPH..... #19158..... \$561.95/ea.

GAS TANK MOUNTING STRAP BOLTS

This is a must-have item for those replacing their old gas tank or gas tank mounting straps. Includes nuts, bolts and washers.



- 1955-57 Best..... #1215..... \$6.95/pr.
- 1955-57 Good..... #16804..... \$2.95/pr.



GAS TANK CENTERING KIT

The Williams Classic gas tank centering kit solves many issues you may run into while continuing your build. This kit gives you a nice symmetrical look for custom and stock style tanks and makes the routing of exhaust much easier. Requires installation of the Williams Classic Spare Tire Eliminator. For custom stainless tanks or fuel cells all that is required is a quick tracing of the side profile of your tank. Available in black, charcoal gray, silver, or bare steel. All required grade 8 hardware and gas tank filler nozzle weld-in extension is included. This kit is also useful for moving your tank back to clear a 4-bar setup.

- 1955-57 #15898 \$269.95/kit



STAINLESS STEEL GAS TANK MOUNTING STRAPS WITH BOLTS

Replace those old rusty straps with our beautiful stainless ones.

1955-57 Hardtop, Sedan & Convertible #2752.....\$36.95/pr.



GAS TANK MOUNTING STRAPS

Remember to replace your gas tank mounting strap bolts # 1215 to finish the job. Fits hardtops, sedans and convertibles.

1955-57 #1214.....\$24.95/pr.



GAS TANK MOUNT  **O/S**

1955-57 Nomad & Wagon..... #12129.....\$194.95/ea.



GAS TANK LOCATOR KIT

This bracket mounts the front of the tank strap to the underside of the trunk floor.

1955-57 #12130..... \$49.95/set



#2885

GAS TANK MOUNTING STRAPS FOR NOMADS AND WAGONS

1955-57 Stainless..... #2885.....\$39.95/pr.
1955-57 Steel..... #2886.....\$41.95/pr.

GAS TANK RELATED



GAS TANK STRAP ANCHOR BRACKET KIT

This bracket welds to the rear of the trunk floor.
1955-57 #11334.....\$41.95/kit

GAS TANK PIPE SUPPORT BRACKET

This bracket secures the gas tank filler pipe to the frame. It is used on 56 and 57 passenger cars and the 1956 9-passenger wagons only.



1956-57 #2617..... \$15.95/ea.

GAS TANK FILLER PIPE HOSE

This fuel transfer hose is constructed of heavy gauge neoprene and connects the upper and lower fuel tank filler hoses together.



1957 & 56-62 Vette #1296..... \$16.95/ea.

1956 GAS TANK TO BODY GROMMET



This "56 Only" grommet prevents the gas tank filler tube from rattling. Made of nitrile rubber to avoid damage from gas fumes. **Made in the USA.**



1956..... #1823..... \$17.95/ea.



GAS TANK FILLER TUBE "O" RING



Made in the USA.
1955-57 #195A..... \$2.95/ea.



1957 GAS TANK FILLER PIPE HOSE AND CHECK VALVE KIT

Prevents splash back during acceleration. Can be installed in 55-56's by cutting the filler pipe.

1957..... #14949..... \$44.95/kit



1957 GAS TANK FILLER PIPE AND VENT HOSE KIT

Contains the hard-to-find vent hose and clamps. The perfect addition to your gas tank restoration.

Made in the USA.
1957 ONLY #2645D..... \$49.95/kit



1957 GAS TANK FILLER PIPE HOSE CLAMPS

One pair needed per car.
1957 Replacement #2643..... \$12.95/pr.

BRASS WIRE TIE

This brass wire tie is used to hold the '57 vent hose to the filler tube. It can also be used under the hood to hold bundles of wires together.



1955-57 #11209..... \$5.95/ea.



GAS TANK FILLER TUBES

Gas cap not included.

1955.....	#12739.....	\$75.95/ea.
1955 Nomad & Wagon.....	#12740.....	\$74.95/ea.
1956.....	#12741.....	\$94.95/ea.
1956 Nomad & Wagon.....	#12742.....	\$119.95/ea.
1957 Lower.....	#12642.....	\$69.95/ea.
1957 Upper.....	#12641.....	\$83.95/ea.
1957 Upper, Nomad & Wagon	#12744.....	\$92.95/ea.
1957 Lower, Nomad & Wagon	#12745.....	\$74.95/ea.

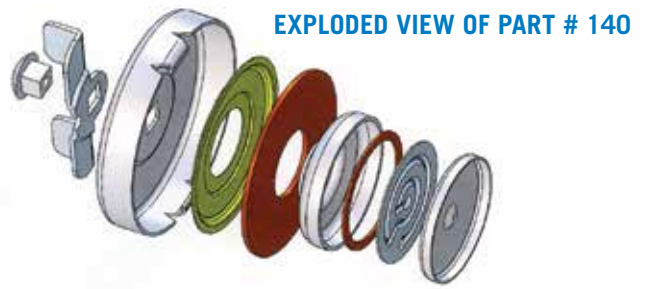

EXPLODED VIEW OF PART # 140

THE ORIGINAL GAS CAP

Our master toolmakers made sure that this gas cap was meticulously reproduced to match the original, including the complex venting system. This is a perfect reproduction **Made in the USA**. You will find none other that even comes close to being correct. Part #16694 is a basic replacement cap that does not have any of the features of part #140. **Made in the USA***.



1953-57 Best..... #140* \$18.95/ea.
 1955-57 Good..... #16694..... \$6.95/ea.



"RED STRIPE" LOCKING GAS CAP

Protect your Chevy with this excellent reproduction gas cap. 1953-57 #139..... \$50.95/ea.



Thanks for sending your photo!

KENT FROM LINDESBERG, SWEDEN

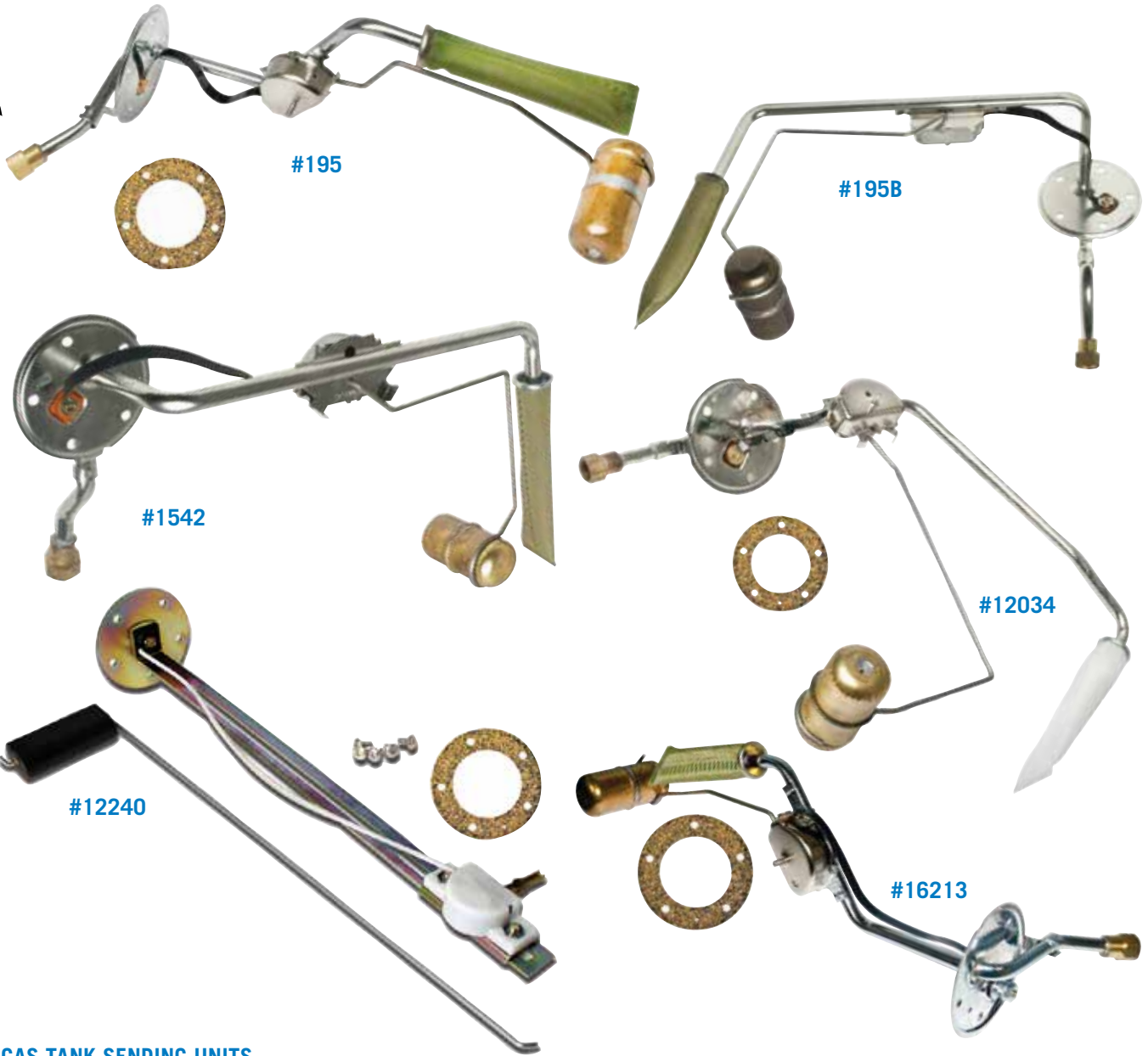

GAS TANK SENDING UNITS

All our senders are 0-30 OHM, like original, with the exception of 16213. Parts #1541 and #1542 are for high performance applications which use a 3/8-inch fuel line. Parts #19154, #19155 and #19156 are for fuel injection applications. It is for use with a 3/8-inch fuel line and it incorporates a 5/16" return line into the sending unit.

1955-57 Best, Hardtop, Sedan & Convertible, 5/16"	#195.....	\$62.95/ea.
1955-57 Good, Hardtop, Sedan & Convertible.....	#16696.....	\$42.95/ea.
1955-57 Best, Nomad & Wagon exc. 9-Passenger Wagon	#195B.....	\$64.95/ea.
1955-57 Good, Nomad & Wagon exc. 9-Passenger	#16697.....	\$49.95/ea.
1956 9-Passenger Wagon.....	#12034.....	\$64.95/ea.
1955-57 Dual 4BC, F.I., 3/8", exc. Wagon, Nomad & Sedan Delivery.....	#1541.....	\$64.95/ea.
1955-57 Dual 4BC, F.I., 3/8", 6-Passenger Wagon, Nomad & Sedan Delivery	#1542.....	\$64.95/ea.
1955-57 Universal Top Mount and TPI.....	#12240.....	\$64.95/ea.
1955-57 w/ Filter, 240-33 OHMS, 5/16", exc. Wagon	#16213.....	\$65.95/ea.
1955-57 exc. Wagon, HP, 3/8" w/ 5/16" Return Line.....	#19154.....	\$75.95/ea.
1955-57 9-Passenger Wagon, HP, 3/8" w/ 5/16" Return Line	#19155.....	\$59.95/ea.
1955-57 exc. 9-Passenger Wagon, HP, 3/8" w/ 5/16" Return Line	#19156.....	\$84.95/ea.



#195C



#195D

GAS TANK SENDING UNIT GASKETS 

Anytime you remove the sending unit from the gas tank this gasket and the screws, #1488, should be replaced, whether you replace the sending unit or not. Part #195D is included with parts #195, #195B, #1541 and #1542
Made in the USA.

- 1955-57 Rubber..... #195C..... \$2.95/ea.
- 1955-57 Cork..... #195D..... \$3.95/ea.



CLASSIC INSTRUMENTS FUEL GAUGE INTERFACE

The FuelLink is a problem-solver that acts as an interface between fuel senders and gauges to correct ohm mis-match and erratic movement due to fuel slosh. In addition, an optional low fuel light trigger is available to trigger an indicator light at 1/8 of a tank.

- All..... #18365..... \$135.95/ea.



#1543

GAS TANK SENDING UNIT FILTERS

This often overlooked item should be replaced regularly. Moisture in the gas will eventually produce rust in the tank. Clogged filters result in poor performance. Remember to replace your gas tank sending unit gasket (#195D) and use a fresh screw set, (#1488) at the same time.

- 1955-57 Delco, 5/16" #1543..... \$9.95/ea.
- 1955-57 Delco, 3/8" #1544..... \$9.95/ea.
- 1955-57 5/16"..... #12696..... \$10.95/ea.
- 1955-57 3/8"..... #12697..... \$10.95/ea.

GAS TANK SENDING UNIT SCREW SET 

When replacing the gas tank sending unit, this screw set is the only way to go. These screws have original 5/32" clutch heads and copper washers. **Made in the USA.**



- 1955-57 5/32" #1488..... \$5.95/set



#1538



#1539

GAS LINE HOSES

Located between the fuel pump and the steel gas line, this reinforced fuel hose has the correct fittings and dimensions to fit into an accurately restored engine compartment.

- 1955-57 2BC, 4BC, 5/16"..... #1538..... \$11.50/ea.
- 1956-57 Dual 4BC, F.I., 3/8" #1539..... \$19.95/ea.

GAS LINES AVAILABLE ON NEXT PAGE



GAS TANK SENDING UNIT FLOATS

- 1955-57 Best..... #11168..... \$10.95/ea.
- 1955-57 Good..... #16724..... \$8.95/ea.



SINGLE GAS LINE CLIP

Properly fasten the gas line with this original style clip. Includes mounting bolt.

- 1956-57 Dual 4BC, F.I., 3/8" #1527..... \$2.95/ea.

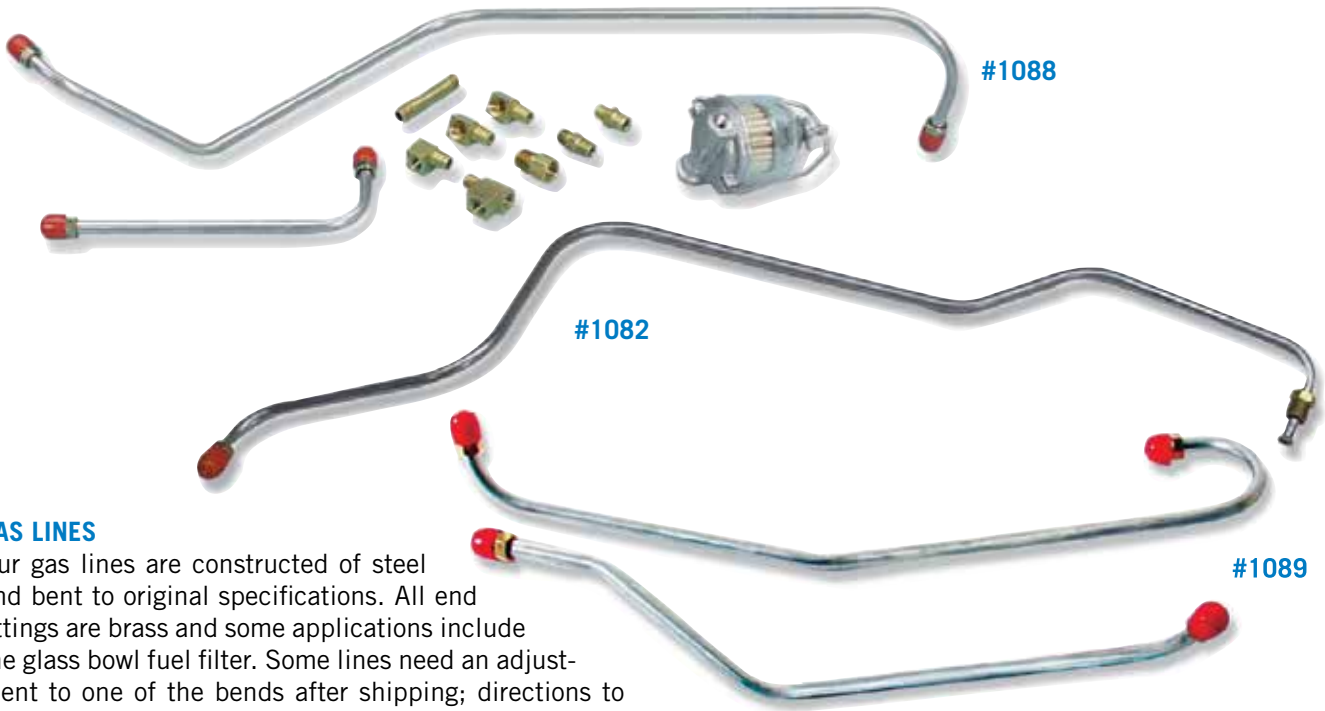

GAS LINES

Our gas lines are constructed of steel and bent to original specifications. All end fittings are brass and some applications include the glass bowl fuel filter. Some lines need an adjustment to one of the bends after shipping; directions to make the bend properly are included. It is important to note that our dual four barrel lines are the only ones that come with true reproduction brass fittings. Don't settle for cheap imitations when the best is here! Note: Glass bowl filters are included with #1085, #1087 and #1088.

1955-57 6-Cyl., Use w/ Fuel Filter, Filter Not Included.....	#1540.....	\$19.95/ea.
1955-57 6-Cyl., Use w/ Filter.....	#19142.....	\$18.95/ea.
1955-57 V8 Use w/ Carter, 4BC, w/o Filter.....	#19143.....	\$18.95/ea.
1955 V8 2BC, 4BC, Use with Fuel Filter, Filter Not Included, 1956 V8 2BC Use with Fuel Filter, Filter Not Included.....	#1555.....	\$18.95/ea.
1955 V8 2BC, 4BC 1/4" Line, Use without Filter, 1956 V8 2BC 1/4" Line, Use without Filter.....	#1082.....	\$35.95/ea.
1955 V8 2BC, 4BC w/ Original Add-On Oil Filter w/ Fuel Filter.....	#1083.....	\$19.95/ea.
1956-57 V8 2BC, 4BC w/o Fuel Filter, 5/16" Line.....	#1084.....	\$18.95/ea.
1956-57 V8 4BC w/ Fuel Filter, 5/16" Line, Filter Included.....	#1085.....	\$56.95/ea.
1956-57 V8 4BC, w/ GF 48 Filter.....	#19145.....	\$18.95/ea.
1956 Dual 4BC w/ Fuel Filter, Filter Included.....	#1087.....	\$82.95/kit
1957 V8 2BC w/ Fuel Filter, Filter Not Included.....	#1556.....	\$18.95/set
1957 Dual 4BC w/ Fuel Filter, Filter Included.....	#1088.....	\$82.95/set
1957 Fuel Injection Pump to Injector Line w/ Fittings.....	#1089.....	\$21.95/ea.
1957 V8 W/ Carter, 4BC, w/ Filter.....	#19144.....	\$18.95/ea.

FRAME GAS LINES PASSENGER CARS O/S

1955-57 6-Cyl., Inside Frame, 5/16".....	#1475.....	\$59.95/ea.
1955-57 6-Cyl., Convertible, Inside Frame, 5/16".....	#19137.....	\$59.95/ea.
1955-57 6-Cyl., Wagon, Inside Frame, 5/16".....	#19138.....	\$59.95/ea.
1955-57 2BC exc. Conv., Inside Frame, 5/16".....	#1476.....	\$64.95/ea.
1955-57 2BC Conv., Inside Frame, 5/16".....	#1477.....	\$59.95/ea.
1955-57 8-Cyl., 2BC Wagon, Inside Frame, 5/16".....	#19139.....	\$59.95/ea.
1955-57 4BC, Outside Frame, 5/16".....	#1478.....	\$74.95/ea.
1955-57 Dual 4BC, F.I., Outside Frame, 3/8".....	#1479.....	\$64.95/ea.
1955-57 V8 2BC, 5/16".....	#18122.....	\$53.95/ea.
1956-57 V8 4BC, Gas Line, Outside Frame, 5/16", 6-Passenger Wagons.....	#1595.....	\$64.95/ea.
1956 V8 Dual 4BC, 1957 V8 Dual 4BC or F. I., Outside Frame, 3/8", 6-Passenger Wagons.....	#1596.....	\$64.95/ea.

SEE PAGE 475 FOR NOTCHED LINE CLAMP KITS



STAINLESS STEEL FUEL AND BRAKE LINE CLAMPS

Single Clamps:

- 3/16", 12 pk. #12095..... \$19.95/set
- 1/4", 12 pk. #12096..... \$19.95/set
- 5/16", 12 pk. #12097..... \$19.95/set
- 3/8", 12 pk. #12098..... \$21.95/set
- 1/2", 12 pk. #12099..... \$19.95/set
- 5/8", 8 pk. #12100..... \$19.95/set
- 3/4", 8 pk. #12101..... \$19.95/set
- 7/8", 8 pk. #12102..... \$19.95/set

Double Clamps:

- 3/16", 6 pk. #12103..... \$19.95/set
- 1/4", 6 pk. #12104..... \$19.95/set
- 5/16", 6 pk. #12105..... \$19.95/set
- 3/8", 6 pk. #12106..... \$19.95/set
- 1/2", 6 pk. #12107..... \$19.95/set
- 5/8", 4 pk. #12108..... \$19.95/set
- 3/4", 4 pk. #12109..... \$19.95/set
- 7/8", 4 pk. #12110..... \$19.95/set

Combos:

- 3/16" x 3/8", 6 pk. #12111..... \$21.95/set
- 5/16" x 3/8", 6 pk. #12112..... \$19.95/set



GAS AND BRAKE LINE FRAME CLIPS

- 1955-57 Inside Frame #1007..... \$29.95/set
- 1955-57 Outside Frame w/ Power Pack (Shown)
..... #1008..... \$35.95/set



ARP STAINLESS FUEL PUMP BOLTS

- All Hex #14009..... \$13.95/set
- All 12-Point..... #14010..... \$13.95/set



REPLACEMENT FUEL PUMPS

These replacement fuel pumps will function like the originals with the proper fit and fuel pressure rating.

- 1955-57 6-Cyl..... #090..... \$79.95/ea.
- 1955-57 V8 #091..... \$74.95/ea.



FUEL PUMP BLOCK-OFF PLATE

Supplied with special non-asbestos gasket, this chrome plate is stamped with the popular Chevrolet bowtie logo.

- All SB..... #1957..... \$8.95/ea.



BILLET SPECIALTIES FUEL PUMP BLOCK-OFF PLATES

- All SB..... #17103..... \$21.95/ea.
- All BB..... #17104..... \$21.95/ea.



ARP FUEL PUMP PUSHRODS

- All BB, Chrome Moly #14017. \$27.95/ea.
- All SB, Chrome Moly #14018. \$27.95/ea.

POLISHED BILLET FUEL PUMP BLOCK-OFF PLATE

- All BB ...#12484...\$9.95/ea.



STAINLESS FUEL PUMP BOLT KIT

- All SB w/ Bowtie #14273....\$7.95/kit



1957 FUEL DOOR BOX INSIDE QUARTER PANEL
 1957 w/ Springs..... #16960..... \$55.95/ea.



1955 GAS DOOR FILLER BRACKET
 1955..... #2105..... \$48.95/ea.



GAS DOOR RUBBER BUMPERS
 1955..... #807..... \$5.50/set
 1957..... #808..... \$4.95/set



1957 GAS DOOR STOP KIT
 1957..... #14178..... \$6.50/kit



1957 GAS DOOR SCREW SETS
 1957..... #2180..... \$4.95/set
 1957 Stainless..... #15424..... \$4.95/set

#2104



#1090



GLASS BOWL FUEL FILTERS

Get rid of that cheap in-line filter and get the genuine article. Our #2104 filter is a reproduction of the original Chevy design, and includes correct AC markings. If you're restoring a driver, use our replacement glass bowl fuel filter, part #1090.

1955-57 4BC #2104..... \$34.95/ea.
 1956-57 4BC #1090..... \$34.95/ea.



ARP EDELBROCK/CARTER AFB FLOAT BOWL BOLT KIT

Replace the fragile torx head bolts with these beautiful 12-point stainless bolts from ARP.

All..... #18226..... \$19.95/kit

REPLACEMENT FUEL FILTER GLASS BOWL ONLY

This is the replacement glass bowl only for the Danchuk #2104 and #1090 fuel filter assemblies.

1955-57 w/ AC Markings #16839..... \$17.95/ea.



FUEL FILTER ELEMENT

Keep your fuel filter clean by replacing it regularly. This filter element fits our glass bowl fuel filter, part #2104, shown above, and is also used in gas line kits #1085, #1087 and #1088 shown on page 312.

1955-57 #1303..... \$5.95/ea.



1957 GAS DOOR SPRINGS

If your gas door is rattling then replacing the springs will make sure it stays tight when closed. Easy to replace.

1957..... #676..... \$6.95/pr.





CARBURETOR BRASS VENT TUBES

The carburetor vent tubes are an important part of a correct and complete 4 barrel carburetor restoration job. Set of 4, 2 front & 2 rear for 2 carbs.

1956-61 2 X 4BBL, Set of 4 #18942..... \$51.95/set



CARBURETOR METERING RODS AND JETS FOR DUAL 4-BARREL CARBURETORS

Worn metering rods will cause the air-fuel ratio to become too rich. These kits contain both the metering rods and jets for the Carter WCFB dual four barrel carburetors.

1957-61 WCFB 2626 & 2627 (Shown) #1840..... \$108.95/set
 1957-61 WCFB 2313 & 2314 #1841..... \$108.95/set

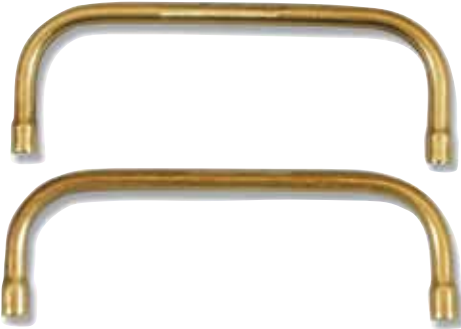

DUAL 4-BARREL CARBURETOR VENT TUBES

The carburetor vent tubes are an important part of a correct and complete 4-barrel carburetor restoration job. Two of each required per carburetor.

1956-57 Front of Carburetor..... #1102..... \$14.95/ea.
 1956-57 Rear of Carburetor #1101..... \$14.95/ea.



CARBURETOR LINKAGES

This assembly includes all the components necessary to completely replace your linkage. Parts are faithful to the originals, but far, far newer!

1956-57 Dual 4BC..... #1103..... \$59.95/set

CARBURETOR MOUNTED LINKAGE BRACKETS

This is a chrome carburetor linkage bracket for used with either Holley, Edelbrock, Rochester Quadrajets or Carter carburetors. It mounts to the base of the carburetor and is designed to be used with a GM style throttle cable. Includes an adapter for use with a 700-R4 or a 200-4R transmission.

All..... #2284..... \$10.95/ea.



BOWL TO CARBURETOR FUEL FILTER FITTINGS #1546

This is the fitting that installs into the carburetor where the fuel line enters when you install the fuel filters, #2104 or 1090. The filter assembly is threaded onto this fitting and then the fuel line is connected to the other side of the fuel filter assembly. One required.

1955-57 Carter, 1/8" NPT on Both Ends #1545..... \$2.95/ea.
 1956-57 Rochester, 1/8" NPT & 1/2-20 (1/4" Inverted Seat)..... #1546..... \$5.95/ea.



CARBURETOR LINKAGE BUSHING/GROMMET KIT

The rubber part of this kit installs in both the carburetor shaft end and the throttle shaft end with the nylon bushing resting inside. The carburetor linkages then go thru this assembly and are held in place with the cotter pin connecting the carb to the throttle linkage.

1955-64 4-Piece..... #17148..... \$8.95/kit





CARBURETOR REBUILDING KITS

We offer carburetor rebuilding kits that cover a wide variety of Chevrolet applications. Refer to the chart on page 316 to determine the kit that is best for your car. Use the Danchuk part number located in the middle and far right columns when ordering your kit.

- 1955-57 (Shown) #080A..... \$45.95/kit
- 1956-57 #080D..... \$41.95/kit
- 1955-57 #080B..... \$29.95/kit
- 1957..... #080F..... \$34.95/kit
- 1955-56 #080G..... \$34.95/kit
- 1955-57 #080H..... \$22.95/kit

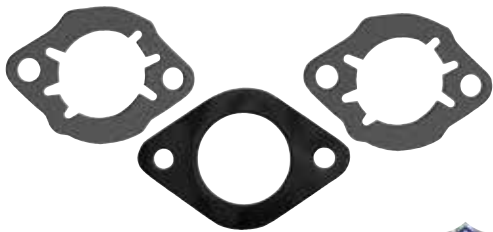

CARBURETOR SPACER BLOCK WITH GASKET

Made to original specs. This US made spacer block and gaskets are the perfect replacement for worn out originals.

- 1955-57 6-Cyl..... #18355..... \$34.95/ea.



CARBURETOR CHOKE HOUSINGS

- 1956-58 Dual 4BC Carter WCFB, Threaded #12234..... \$45.95/ea.
- 1957-58 4BC Carter WCFB, Unthreaded #12235..... \$45.95/ea.



CHOKE SHAFT WITH BUTTERFLY

If your choke shaft and butterfly is missing from your carburetor this quality reproduction will get your classic back on the road in no time.

- 1955-58 4BBL..... #18947..... \$21.95/ea.



1955-58 CHOKE RELEASE ROD

When the choke release rod is missing from your carburetor it can make starting the engine a real problem. Replace yours with this quality reproduction.

- 1955-58 WCFB 4-BBL Carb #18946..... \$12.95/ea.

CARBURETOR REBUILDING KITS							CARBURETOR REBUILDING KITS				
Year	V8 Engine	Carburetor Type	Barrels	Carburetor Number	Danchuk Part #	Year	6 Cylinder Engine	Carburetor Type	Barrels	Carburetor Number	Danchuk Part #
1956-57	265, 283 w/ 2/4BC	Carter WCFB	4	2362; 2419; 2613, 14, 26, 27; 3181, 82	080A	1957	235	Rochester BC	1	7009656, 657, 784; 7011102; 7012127, 129, 502; 7013000, 003, 005, 955, 956, 7019000	080F
		Carter WCFB	4	2366; 2505, 55; 2655	080A						
		Rochester GC	4	7008737; 7009846; 7012126	080D						
1955-57	265, 283	Rochester GC	2	7005810; 7006825; 7008004, 005, 387 388; 7009345; 7010647, 648, 719; 7011131, 149, 224	080B	1955-56	235	Rochester BC	1	7001374; 7002050; 7003152; 160, 526 865, 986, 7004475, 477, 478, 495, 620, 915; 7005921, 922, 982, 7007172, 180, 181; 7009253, 254, 255	080G
1955	265	Carter WCFB	4	2218, 2351, 3759	080A	1955-57	235	Carter YF	1	756; 787; 788; 789; 964; 965; 966; 967 2008, 46; 2100, 01; 3211	080H



CARBURETOR AIR CLEANER RODS

Measured sizes are approximate.

1955 V8 4BC, 8-1/2".....	#1186.....	\$7.95/ea.
1955-56 V8 2BC, 7-1/2".....	#1187.....	\$9.95/ea.
1956 V8 4BC, 8-3/8".....	#1188.....	\$7.95/ea.
1956-57 Dual 4BC Pots to Air Cleaner, 7-7/8".....	#1189.....	\$9.95/ea.
1957 V8 Dual 4BC Air Clnr. to Carb, 7-1/2".....	#1190.....	\$17.95/set
1957-58 F.I., 4-3/4".....	#1191.....	\$7.95/ea.
1957 V8, 2BC.....	#11232.....	\$9.95/set
1957 V8, 4BC.....	#11233.....	\$9.95/set



CARBURETOR RETURN SPRINGS

1955-58 2BC.....	#1306.....	\$6.95/ea.
1955-58 4BC.....	#1309.....	\$8.95/ea.
1955-59 6-Cyl., Standard.....	#1307.....	\$8.95/ea.
1955-59 6-Cyl., Automatic.....	#1308.....	\$8.95/ea.



CARBURETOR BASE GASKETS

1957 WCFB Dual 4BC.....	#14171.....	\$4.95/ea.
1956-57 WCFB Single 4BC (Shown).....	#14174.....	\$4.95/ea.



PUSH-ON CARBURETOR CLIPS WITH SPRINGS

1955-57 Carter WCFB.....	#14180.....	\$16.95/set
--------------------------	-------------	-------------



CARBURETOR STUD KITS

The #14036 and #14037

are for use with 1/2 carburetor spacers.

All Black Oxide.....	#14036.....	\$25.95/set
All Stainless.....	#14037.....	\$33.95/set
All Standard Length, Black Oxide.....	#14019.....	\$25.95/kit
All Standard Length, Stainless.....	#14020.....	\$34.95/kit

CARBURETOR INSULATOR

The insulator for the 235 6-cylinder engines is now available. No more making do with a cracked and brittle original. Be sure to order the required gaskets to do the job right.



1955-57 Original, 6-Cyl.....	#16638.....	\$7.95/ea.
------------------------------	-------------	------------

CARBURETOR INSULATOR GASKET

The insulator gaskets for the carburetor insulator are now available. Two are required per vehicle. Used only on the 6-cylinder engine.



1955-57 6-Cyl.....	#16639.....	\$2.95/ea.
--------------------	-------------	------------

CARBURETOR SCREW SETS

After reconditioning the carburetor, it would be a shame to reassemble it with old or incorrect screws. These original design slotted filister head screws are cad plated and include stainless steel lock washers.



1955-64 2BC Rochester.....	#1885.....	\$5.95/set
1956-61 Dual 4BC Carter.....	#1886.....	\$22.95/set
1956-64 4BC Rochester.....	#1887.....	\$5.95/set



AIR HORN GASKET FOR WCFB DUAL 4-BARREL

1955-57.....	#14172.....	\$4.95/ea.
--------------	-------------	------------



LOKAR HI-TECH THROTTLE CABLES

These are designed with a specially extruded liner for extended life of the cable. Cables are equipped with aluminum fittings and aluminum ferrule to eliminate fraying. "U-Cut-to-Fit" outer housing available in 24" or 36" lengths with a "U-Cut-to-Fit" stainless inner wire. Clevis is designed with cotter pins or set screws. Includes complete installation instructions.

- All 24", Hi-Tech, Stainless #11257 \$69.95/ea.
- All 24", Hi-Tech, Black #11258 \$59.95/ea.
- All 24", Hi-Tech, Stainless, LT1 & LT4 Tuned Port
..... #11259 \$89.95/ea.
- All 24", Hi-Tech, Stainless, LS1 & 350 Ramjet
..... #13014 \$85.95/ea.
- All 36", Hi-Tech, Stainless #13018* \$79.95/ea.
- All 24", Hi-Tech, Black #16278 \$79.95/ea.
- All 36", Hi-Tech, Black #16279 \$89.95/ea.
- All 36", Hi-Tech, Black, LS1/350 Ramjet
..... #16280 \$89.95/ea.



LOKAR REPLACEMENT INNER THROTTLE CABLE FOR LOKAR ASSEMBLIES

- All 36" #14828 \$29.95/ea.



LOKAR THROTTLE CABLE BRACKETS FOR EDLEBROCK CARBURETORS

Machined aluminum for strength and style and fits single and dual Edelbrock carburetors. Allows easy installation of Lokar cable kits and comes with dual stainless return springs and hardware.

- All #15099 \$99.95/ea.
- All Black Anodized #16284 \$109.95/ea.



LOKAR THROTTLE CABLE BRACKET AND RETURN SPRING KITS

Stainless bracket mounts to the rear of Holley, Edelbrock, AFB, Quadrajet and In-Line Dual Quad carbs. Stainless bracket and GM designed dual stainless springs are used to mount Lokar's throttle cable and kickdown assemblies.

- All #11269 \$39.95/kit
- All Black Anodized #16285 \$44.95/kit



LOKAR CARBURETOR END FOR LOKAR THROTTLE CABLES

- All #14827 \$29.95/ea.



THROTTLE SHAFTS WITH ARMS

1957 Front & Rear, WCFB Dual 4BC

- #12282..... \$191.95/pr.
- 1957 Front, WCFB Dual 4BC..... #12283..... \$95.95/ea.
- 1957 Rear, WCFB Dual 4BC..... #12284..... \$95.95/ea.



THROTTLE ARMS

- 1955-57 V8 #1157..... \$16.95/ea.
- 1957 F.I. #12286..... \$84.95/ea.



1957 FAST IDLE ASSEMBLY FOR WCFB DUAL 4-BARREL

- 1957..... #14175..... \$59.95/ea.



THROTTLE PLATES

- 1956-57 WCFB..... #12285..... \$14.95/set



FAST IDLE SCREW & SPRING

- 1955-57 AFB & WCFB..... #14184..... \$4.95/ea.



IDLE MIXTURE ADJUSTMENT SCREWS

- 1956-57 Carter Dual 4BC..... #14181..... \$10.95/set
- 1955-57 Carter 4BC #14182..... \$9.95/set

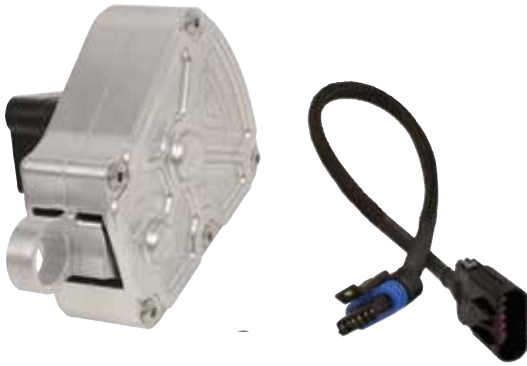

DRIVE BY WIRE THROTTLE CONTROLS WITH HARNESSES

The first programmable electronic throttle pedal (Drive By Wire) for the automotive aftermarket includes a programmable non-contact (Solid State) Hall Effect Sensor for most GM, Ford & Mopar applications. Also features a splined pedal arm for versatile mounting and all metal construction; aluminum and stainless steel. You can expect three times better performance over standard OEM pedals coming from over 90 years of combined throttle pedal experience. Sensor is programmed on the pedal to optimize electrical output for quick throttle response and no pedal lag. Pedal assembly sold separately.

- GM Crate Motors**..... #18375..... \$434.95/ea.
- 2007-2017 Silverado** #18376..... \$434.95/ea.
- 2006-12 Corvette** #18377..... \$434.95/ea.



DRIVE BY WIRE BILLET THROTTLE PEDAL

Throttle pedals are required to complete your drive by wire throttle pedal assembly.

- All w/ Rubber Insert** #16856..... \$137.95/ea.



LOKAR BILLET ALUMINUM TUNED PORT BRACKETS

These billet aluminum brackets mount to the side of the tune-port housing. The billet aluminum bracket is available with a single stud for throttle only; double stud for throttle and kickdown and triple stud for throttle, kickdown and cruise control cable.

- 1955-57 Single Stud** #12174..... \$54.95/ea.
- 1955-57 Double Stud**..... #12175..... \$54.95/ea.
- 1955-57 Triple Stud** #12176..... \$54.95/ea.



LOKAR BILLET THROTTLE PLATE WITH KICKDOWN AND RETURN SPRING KITS

Throttle plate includes brackets for the throttle cable, kickdown cable and spring return kit. Complete with two stainless steel return springs for safety.

- All Black** #17556..... \$186.95/kit
- All Brushed**..... #17557..... \$186.95/kit

LOKAR THROTTLE/KICKDOWN CABLE BRACKETS

Lokar's answer to LT1/4 cable problems. Stainless throttle and kickdown brackets replace factory brackets. Kit includes stainless arm to mount on LT1/4 throttle body to operate kickdown. Designed to be used with Lokar's tuned-port throttle and kickdown cables.



- 1992-'93 LT1** #13257..... \$89.95/ea.
- '94-Up LT1, LT4** #13258..... \$89.95/ea.



EDELBROCK THROTTLE SOLENOID AND BRACKET KIT

All..... #13356..... \$176.95/kit



1957 CHOKE ASSEMBLY

For 2627S & 2614S Carburetors.

1957 Dual 4BC..... #14185..... \$89.95/set



1957 CHOKE SHAFT AND BUTTERFLY VALVE

1957 WCFB 4BC & Dual 4BC..... #14186..... \$21.95/set



CHOKE TUBE HEAT KIT

Here's a convenient replacement kit for those burned-out originals. Easily installed, this kit will return your choke to smooth operation.

1955-57 #087..... \$19.95/kit

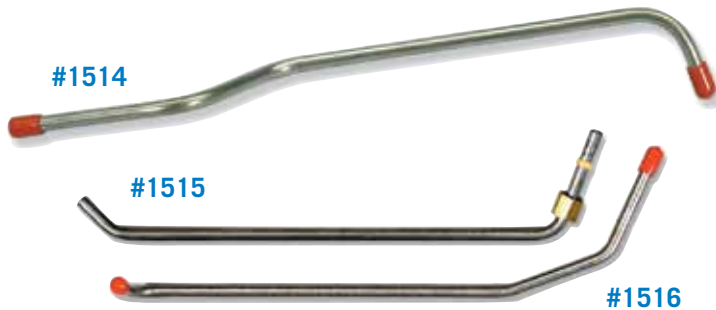

CHOKE HEAT RISER TUBES

Without this important part the carburetor cannot take advantage of the warm air from the exhaust manifold upon start-up. Bring back the efficiency and performance your car was designed with, and help restore the original look of your engine.

- 1955-56 6-Cyl. (Shown) #1514..... \$5.95/ea.
- 1955-56 2BC (Shown) #1515..... \$5.95/ea.
- 1955-56 Carter 4BC (Shown) #1516..... \$5.95/ea.
- 1956 Dual 4BC..... #1520..... \$5.95/ea.
- 1956 V8 Rochester 4BC..... #19146..... \$5.95/ea.
- 1957 6-Cyl..... #1517..... \$5.95/ea.
- 1957 2BC..... #1518..... \$5.95/ea.
- 1957 4BC..... #1519..... \$5.95/ea.



Photo courtesy of GERTMAN2000



#2594

CHOKE COVER

1957-62 (& Vette) WCFB #2594..... \$49.95/ea.



#17226

EDELBRUCK UNIVERSAL CHOKE CABLE KIT

All..... #17226..... \$17.95/kit



CHOKE COVER

1955-56 4BC, Dual 4BC, Carter WCFB
..... #11220..... \$28.95/ea.



INTAKE MANIFOLD FITTINGS

See page 367 for stainless fittings.
1955-56 5/8" #10066..... \$17.95/ea.
1957 3/4" #12225..... \$16.95/ea.



#14763

#14764

#14765

VACUUM HOSE NIPPLE

1955-57 Stainless, 1/4" ID x 1-1/2", 1/8" NPT
..... #14764..... \$10.95/ea.

VACUUM/FUEL HOSE NIPPLES

1955-57 Stainless, 3/8" ID x 1-1/2", 1/8" NPT
..... #14763..... \$11.95/ea.
1955-57 Stainless, 3/8" ID x 1-3/4", 3/8" NPT
..... #14765..... \$13.95/ea.



#14761

#14762

VACUUM HOSE FITTINGS

1955-57 2-Port, Stainless, 3/8" NPT w/ 1/8" NPT Ports
..... #14761..... \$22.95/ea.
1955-57 1-Port, Stainless, 3/8" NPT w/ 1/8" NPT Ports
..... #14762..... \$19.95/ea.
All Vacuum Hose, 3/16" Hose, 1/8" NPT, Stainless
..... #15304..... \$11.50/ea.



INTAKE THERMOSTAT HOUSING STUDS

1956-61 Dual 4BC & FI..... #2654..... \$4.95/pr.



INTAKE MANIFOLD STUDS

1955-57 6-Cyl. to Manifold..... #11208..... \$3.50/set



STAINLESS INTAKE MANIFOLD BOLTS

- All Hex, 396-454 BB..... #13993..... \$72.95/set
- All 12-Point, 396-454 BB (Shown) #13994..... \$75.95/set
- All Hex, SB exc. Vortec (Shown) ... #13995..... \$54.95/set
- All 12-Point, SB exc. Vortec #13996..... \$57.95/set
- All Hex, SB w/ Vortec #13997..... \$39.95/set
- All 12-Point, SB w/ Vortec #13998..... \$43.95/set

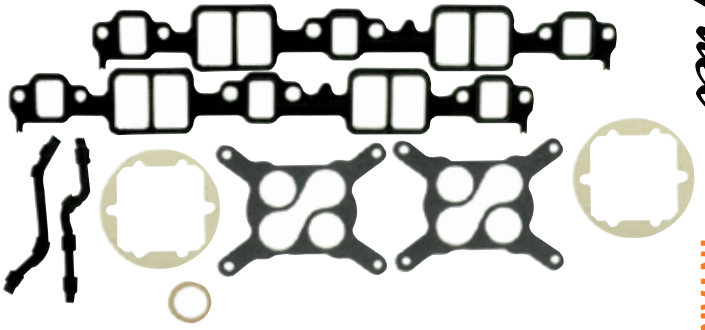

INTAKE MANIFOLD AND CARBURETOR GASKET KITS

This kit includes manifold, carburetor, and air filter housing gaskets for single or dual four barrel carburetor configurations.

- 1957-61 Dual 4BC..... #1350.....\$48.95/kit
- 1957-60 Single 4BC..... #1350A.....\$51.95/kit



INTAKE MANIFOLD BOLTS

- All SB..... #13390..... \$13.95/set
- All BB..... #13391..... \$17.95/set

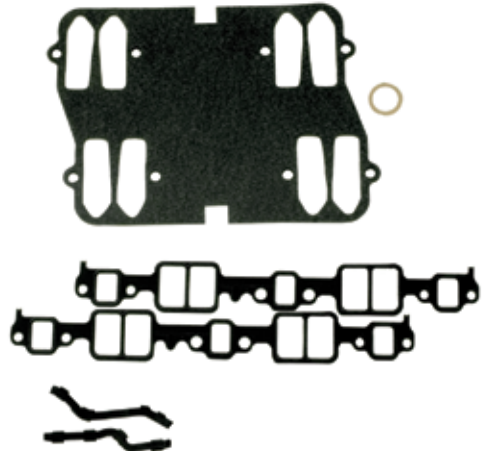

INTAKE MANIFOLD AND FUEL INJECTION GASKET KIT

Includes manifold and fuel injection unit gaskets.

- 1957-58 Fuel Injection. #1351.....\$56.95/kit



INTAKE MANIFOLD BOLTS

These bolts are exact duplicates of the originals with the correct head markings. 12 per set.

- 1955-63 #2652..... \$20.95/set



INTAKE MANIFOLD GASKETS WITH BLOCK-OFF PLATE

These gaskets, with exhaust crossover block off plates, keep the intake manifold cooler providing for a denser fuel mixture.

- 1955-56 #14867..... \$41.95/set
- 1957-64 Dual 4BC & Fuel Injection #2655..... \$42.95/set



INTAKE MANIFOLD WASHERS

- 1955-64 SBw/ Aluminum Manifold #2195..... \$8.95/set

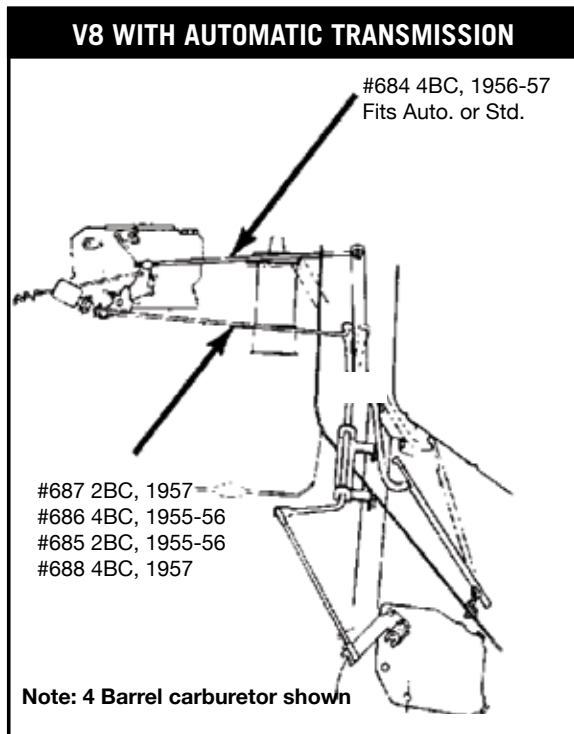
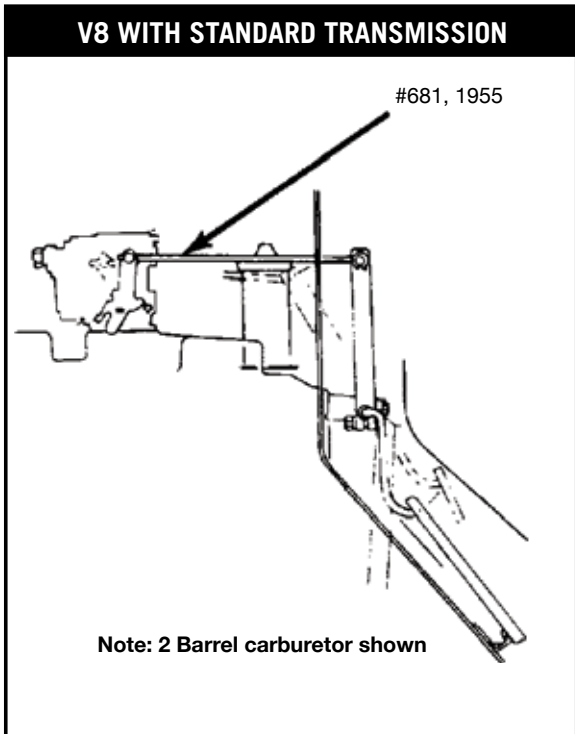
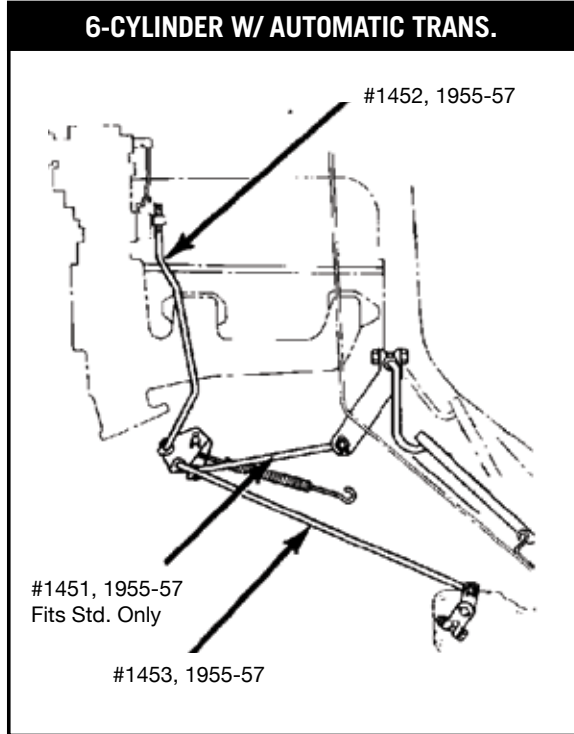

ACCELERATOR LINKAGE SLEEVE

All 1955-67 GM engines use two sleeves each except for 4 barrel carburetors and fuel injected cars, which use only one. See part #079 shown at right.



1955-67 #1877 \$2.95/ea.

CARBURETOR GROMMET

This grommet is necessary to connect the carburetor linkage to the carburetor. Don't forget an accelerator linkage sleeve, part #1877, shown at left.



1955-57 #079 \$3.95/ea.



#681



#682



#683



#684



#689



#1451



#1452

ACCELERATOR LINKAGE ASSEMBLIES

Limping around on a shoddy accelerator linkage rod? Are you missing out on that burst of power due to a broken passing gear linkage rod? Don't leave safety to chance, replace these critical parts with dependable new ones. Measured sizes are approximate.

1955 V8 2BC, 10-1/2".....	#681.....	\$31.95/set
1955 V8 4BC, 11".....	#682.....	\$31.95/set
1956-57 V8 2BC, 10-1/8".....	#683.....	\$31.95/set
1956-57 V8 4BC, 11".....	#684.....	\$31.95/set
1957 F.I., 6-1/2".....	#689.....	\$24.95/set
1955-57 6-Cyl., Lower, 10".....	#1451.....	\$23.95/set
1955-57 6-Cyl., Upper, 12-1/2".....	#1452.....	\$23.95/set

LINKAGE ROD CLIPS

When replacing linkage rods, it's a good idea to replace your linkage rod clips. Part #1566 is equivalent to GM part #3700188 and part #1567 is like GM part #3711177.

1955-57 Right Hand Type.....	#1566.....	\$1.95/ea.
1955-57 Left Hand Type.....	#1567.....	\$1.95/ea.



#685



#688



#686



#1453



#2199

UPPER PASSING GEAR LINKAGE RODS

1955-56 V8 2BC, 9-1/2".....	#685.....	\$24.95/set
1955-56 V8 4BC, 10-3/4".....	#686.....	\$24.95/set
1957 V8 2BC, 11-1/2".....	#687.....	\$24.95/set
1957 V8 4BC, 12-5/8".....	#688.....	\$24.95/set
1955-57 6-Cyl., 12-3/4".....	#1453.....	\$24.95/set
1955 Early Model 4BC, 7-1/2".....	#2199.....	\$24.95/set

LOWER PASSING GEAR LINKAGE RODS

1955-56 (Shown).....	#1876.....	\$34.95/ea.
1957-62.....	#1884.....	\$16.95/ea.



LINKAGE BRACKET AND SPRING CARBURETOR/ACCELERATOR

1956-64 Dual 4BC.....	#11231.....	\$34.95/set
-----------------------	-------------	-------------

ACCELERATOR PEDAL ROD BUSHINGS

These bushings support the accelerator pedal rod where it runs through the bracket that mounts to the firewall. There is one on each end of the bracket tube and the accelerator rod slides through them.



1955-57 Through Firewall.....	#12648.....	\$3.95/pr.
-------------------------------	-------------	------------

AIR CLEANERS



#13837

#13836

ANODIZED ALUMINUM AIR CLEANERS WITH BOWTIE LOGOS

Super-light 14-inch air cleaners are made of aircraft aluminum in either black or clear anodized finishes plus a 3-inch AC filter, recessed aluminum base and mounting hardware.

- All 14" Black #13836..... \$96.95/ea.
- All 14" Clear #13837..... \$96.95/ea.



#13833

BLACK CRINKLE AIR CLEANER CHEVROLET WITH BOWTIE WING NUT

- All 14", 5-1/8" Flange #13833..... \$86.95/ea.



#13162

EDELBRÖCK AIR CLEANER

Fits carburetor w/ 5-1/8-inch flange.

- All Chrome, 14" w/ 3" Element #13162..... \$34.95/ea.

EDELBRÖCK AIR CLEANER PRO-FLO SERIES

- All Black, 14" #18462..... \$34.95/ea.



#15000

#15002

EDELBRÖCK CLASSIC FINNED AIR CLEANERS

Classic Finned design harkens back to the vintage look of the 50's and 60's. They feature cleanable filter elements and come in either polished or classic black. Dual 4-barrel applications are for carburetors with a 6-7/16-inch center to center spacing. 5-1/8-inch flange.

- All Polished, Small Oval, 4BC #15000.... \$239.95/ea.
- All Polished, Large Oval, Dual 4BC #15001..... \$238.95/ea.
- All Black, Small Oval, 4BC #15002..... \$163.95/ea.
- All Black, Large Oval, Dual 4BC #15003..... \$173.95/ea.

EDELBRÖCK VICTOR SERIES AIR CLEANERS

Victor series air cleaners feature a textured black powder coated finish for a pleasing and unique finish same as the NASCAR series manifolds. 5-1/8-inch flange.



- All Black, 14" Round w/ 3" Element #14997..... \$141.95/ea.
- All Black, Oval w/ 2.4" Element #14998..... \$125.95/ea.



BILLET SPECIALTIES OVAL AIR CLEANERS

Fits 4-barrel carbs with a 5-1/8 air horns.

- All Small, Ball Milled #17069..... \$134.95/ea.
- All Large, Ball Milled #17070..... \$149.95/ea.
- All Large, Ribbed, Polished #17064..... \$179.95/ea.



BILLET SPECIALTIES AIR CLEANERS

- All Vintage 14", 4BC, Polished #17584..... \$249.95/ea.
- All Vintage 14", 4BC, Black #17585..... \$249.95/ea.
- All Classic 14", 4BC, Polished #17586..... \$229.95/ea.

RETRO ROD AIR CLEANER ASSEMBLY

Based on the 56 Cadillac/Olds air cleaner assembly. This 7/8 scale version was built with Tri-fives in mind. Designed to clear the factory wiper motor and aftermarket HEI distributors. Fits 4-barrel carbs with 5-1/8 air horn and includes filter and rocket shaped wing nut.



- All 4BC..... #17987..... \$146.95/ea.

BILLET SPECIALTIES STREAMLINE AIR CLEANER

Billet Specialties Streamline air cleaners offer a fresh new look for your classic Chevy. Precision machined billet aluminum tops capped off with a 3D machined wing nut compliment any exterior cues.



- All 14" Round, Black #17791..... \$289.95/ea.

CHROME AIR CLEANER

This beautiful chrome air cleaner includes a genuine AC Delco air filter for maximum airflow. Top quality chrome plating protects each part. All air cleaners fit carburetors with 5-1/8" diameter air horns. Note: After installation, lower hood slowly to confirm sufficient clearance.



- All 14" #1946..... \$68.95/ea.



Photo courtesy of GERTMAN2000



ARP AIR CLEANER STUD KITS

- All 1/4" x 2.443"..... #18227.....\$8.95/kit
- All 1/4" x 2.70"..... #18228.....\$11.95/kit
- All 1/4" x 3.20"..... #18229.....\$11.95/kit

AIR CLEANER SPACERS

These air cleaner spacers mount between the carburetor and air cleaner assembly. They fit 4-barrel air cleaners with a 5-1/8" opening. Air cleaner spacers give you additional clearance for fuel lines, linkage, etc.



- All 3/4" #15277..... \$7.95/ea.
- All 1/2" #15278..... \$11.95/ea.

AIR CLEANER OIL RESERVOIR SEAL

Disassemble the air cleaner and you're likely to find the oil reservoir seal damaged or missing entirely. Without this seal, the air cleaner assembly can be bent out of shape by over tightened bolts.



- 1955-56 4BC #1747..... \$6.50/ea.



AIR CLEANER TO CARBURETOR GASKETS

- 1955-57 V8 2BC #2201..... \$2.50/ea.
- 1955-57 V8 4BC #2201A..... \$2.95/ea.



BATWING AIR CLEANERS ^{O/S}

We have been missing these beautiful reproductions for a few years now but we are very happy to say that they are back and, literally, better than they have ever been. All of the tooling has been completely re-made or re-worked and the results are amazing. These babies are as beautiful as the picture you're looking at. **Made in the USA.**

- 1956 Dual 4BC..... #1901..... \$1295.95/ea.
- 1957 Dual 4BC w/ Deluxe Heater.. #1901A... \$1295.95/ea.
- 1957 Dual 4BC w/ Standard Heater
..... #1901B... \$1295.95/ea.

1957 AIR CLEANER CONVERSION KIT

Contains air cleaner bottom parts to convert a 1958 2 or 4-barrel carburetor air cleaner to a 1957 4-barrel carburetor.



- 1957 4BC..... #2646..... \$82.95/kit

AIR CLEANER LOWER SUPPORT BRACKET

The 1955 and 1956 air cleaners are supported by the carburetor and this bracket, which mounts to the intake manifold. Replace that rusty original.



- 1955-56 6-Cyl..... #1490..... \$23.95/ea.

AIR CLEANER WING NUTS

These quality die-cast wing nuts are offered in two sizes. Use the larger size for the 14" and 10" air cleaners, and the smaller size for the 6-3/4" air cleaner. Nut bodies are chrome, with glossy red and black plastic inserts, coated with durable epoxy. Nuts fit both 1/4"-20 and 5/16"-18 studs.



- All Small, Bowtie #1948 \$11.95/ea.
- All Large, Bowtie #1947 \$13.95/ea.
- All Small, Hi-Tech Spinner #1950 \$11.95/ea.
- All Large, Hi-Tech Spinner #1949..... \$13.95/ea.

**AEROMOTIVE HIGH OUTPUT
BILLET FUEL PUMPS**

Ideal for carbureted power plants not using a separate fuel pressure regulator. The H/O Fuel Pump is designed for engines making 200-600 HP and is ideal for street cars and mild race cars alike. Similar to our SS Fuel Pump (Part #17715), but internally regulated to 7 PSI.



All 7 PSI..... #17716..... \$249.95/ea.



AEROMOTIVE STEALTH 340 FUEL PUMP

The Aeromotive 340 Stealth fuel pump will replace the pump supplied in the Danchuk # 17742 and 17743 Aeromotive universal in tank kits, the pump in the # 17744 Aeromotive Tri-Five fuel tank and the pump that comes supplied with the Danchuk # 14947 and 14948 OE style FI fuel tanks. It may also fit other aftermarket FI tanks.

All..... #18991..... \$122.95/ea.

**AEROMOTIVE SS SERIES
BILLET FUEL PUMPS**

A fuel pump that allows you to step up your performance by maintaining optimal line pressure and delivering high volume. The Street/Strip Pump was engineered for 200-750 HP carbureted engines making this a perfect choice for a daily driver, street rod or demanding ET-bracket race car. Comes with 3/8" NPT ports.



All SS Series, 14 PSI..... #17715..... \$235.95/ea.



AEROMOTIVE A750 FUEL PUMP

The Aeromotive A750 fuel pump is compact, quiet and durable. Made from billet, these in-line pumps are ideal for low to medium HP applications. Perfect for street rods and muscle cars, fuel injected or carbureted. Handles fuel injected engines up to 800HP naturally aspirated and 600HP with forced air induction. Handles carbureted engines up to 1000HP naturally aspirated and 800HP with forced air induction. The A750 is also fully submersible for custom in tank placement and has ORB-8 inlet and ORB-6 outlet ports. Not suited for diesel fuel applications.

All Black..... #18994..... \$423.95/ea.

**AEROMOTIVE SS SERIES
PLATINUM BILLET FUEL
PUMPS**

Same as our #17715 pump, but with a mirror nickel finish for the show car builder.



All 14 PSI..... #17717..... \$283.95/ea.



AEROMOTIVE A1000 FUEL PUMP

The Aeromotive A1000 fuel pump is durable, reliable, good looking and it supports high horsepower. Perfect for the daily driver that doesn't run like a daily driver. Handles fuel injected engines up to 1300HP naturally aspirated and 1000HP with forced air induction. Handles carbureted engines up to 1500HP naturally aspirated and 1200HP with forced air induction. The A1000 is also fully submersible for custom in tank placement and has ORB-10 inlet and outlet ports. Not suited for diesel fuel applications.

All..... #18993..... \$439.95/ea.

**AEROMOTIVE PHANTOM
UNIVERSAL IN-TANK FUEL PUMPS**

Aeromotive Phantom Stealth Fuel Systems solve the problem of what to do for a tank when making a switch to EFI or swapping a late model engine into your classic. These fully universal systems will fit virtually any tank from 5.5" to 11" deep, plastic, steel, aluminum, corrugated or smooth. All you do is cut a hole in the top of your tank, measure the depth, cut your pump hanger bracket to length and trim your baffle/basket foam and install. The 340 system will support 700 HP EFI supercharged or 1000 HP carbureted supercharged. The 200 system will support 425 HP EFI supercharged or 500 HP carbureted supercharged or 550 HP EFI normally aspirated or 750 HP carbureted normally aspirated. Must be used with a return style system.



All 340 Pump	#17742.....	\$549.95/ea.
All 200 Pump	#17743.....	\$529.95/ea.



AEROMOTIVE BILLET FUEL PUMP BRACKET

For use with part #17715-17 fuel pumps. Features mirror nickel finish.

All 2-1/2" Diameter	#17718.....	\$112.95/ea.
----------------------------------	--------------------	---------------------



AEROMOTIVE BILLET FUEL FILTER BRACKETS

For use with Aeromotive in-line filters. Part #17725 features a mirror nickel finish.

All In-Line	#17722.....	\$89.95/ea.
All Platinum Series	#17725.....	\$99.95/ea.

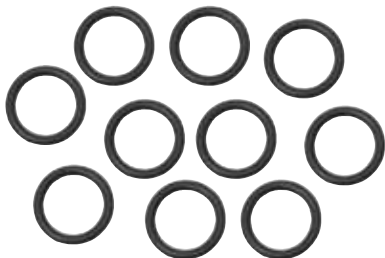

AEROMOTIVE FUEL RESISTANT NITRILE O-RINGS

Fuel resistant nitrile O-rings. Pack of 10 for servicing ORB type fitting on Aeromotive filters and regulators.

All -6AN, 10-pk	#17737.....	\$11.95/kit
All -8AN, 10-pk	#17738.....	\$11.95/kit
All -10AN, 10-pk	#17739.....	\$11.95/kit

AEROMOTIVE ORB-6 HEX PORT PLUG

These Aeromotive plugs are the right way to cap off ports in fuel and other components. The hard-anodized aluminum plugs use O-rings for proper sealing.



All.....	#18186.....	\$6.95/ea.
-----------------	--------------------	-------------------

AEROMOTIVE FUEL FILTER REPLACEMENT O-RINGS

Replacement O-rings for servicing Aeromotive's in-line fuel filters.

All 10-pk.....	#17719.....	\$8.95/kit
-----------------------	--------------------	-------------------

AEROMOTIVE CARBURETED PHANTOM IN-TANK UNIVERSAL FUEL SYSTEM

Aeromotive's all-new returnless Carbureted Phantom is a cost-effective way to install a fuel system for any carbureted system, in virtually any fuel tank. For those customers who want the ease of a returnless carbureted system in their car and are tired of loud, noisy T-style pumps, Aeromotive's new Carbureted Phantom is the way to go. Line pressure is pre-set to 15 psi. Equipped with the Aeromotive Stealth 325 pump, the Phantom Carbureted System is capable of supporting up to 900 horsepower naturally aspirated, 750 horsepower forced induction, on gasoline. **REQUIRES** the use of a fuel pressure regulator suitable for your particular application. Not suitable for use with diesel, E85 Ethanol or Methanol.



All..... #18992..... \$441.95/ea.



AEROMOTIVE IN-LINE FUEL FILTERS

An inexpensive insurance policy to protect your investment, proper filtration is key to fuel system performance. Engineered filter solutions are required to achieve protection with minimum restriction. For 200-3,000 plus HP applications, our filter assemblies offer unmatched flow, ease of installation and maintenance, along with the impeccable machining and finish you've come to expect from all Aeromotive components. 10 Micron filters are for use after the fuel pump, 100 micron filters are used before the pump.

All 10 Micron, Red..... #17720..... \$119.95/ea.
 All 100 Micron, Red..... #17721..... \$149.95/ea.

AEROMOTIVE IN-LINE FUEL FILTERS

Same as #17720-21, but with mirror nickel finish for a chrome like appearance.

All 10 Micron, Platinum Series..... #17723..... \$129.95/ea.
 All 100 Micron, Platinum Series... #17724..... \$157.95/ea.



AEROMOTIVE REPLACEMENT FILTER ELEMENTS

Commonly the most overlooked component in a fuel system, filter neglect can be the most costly. If not cleaned or replaced regularly, filter elements can become clogged resulting in reduced fuel flow, engine performance and ultimately, fuel pump or even worse, engine damage. By simply replacing and/or cleaning your filter elements regularly, you can avoid costly repairs to your fuel system and ensure peak engine performance. For use with part #17720 or 17721.

All 10 Micron #17726..... \$19.95/ea.
 All 100 Micron #17727..... \$45.95/ea.

AEROMOTIVE REDUCER FITTINGS

Use on fuel systems where a reduction in port size is required such as Aeromotive's in-line fuel filters.



All ORB -10 to -6 AN Black..... #17740..... \$19.95/ea.
 All ORB -10 to -8 AN Black..... #17741..... \$19.95/ea.



AEROMOTIVE UNIVERSAL (CARB/EFI) BYPASS REGULATORS, 3-PORT

A dual purpose, universal regulator for EFI or carbureted street or strip applications. Base pressure adjustable from 3 to 20 PSI with standard spring, (installed) or from 20 to 60 PSI with high pressure spring (included). Offers the full flow and rock steady fuel pressure that only a dynamic, Aeromotive bypass regulator provides. Platinum series features mirror nickel show car finish.

- Capable of regulating any fuel pump between 100 and 250 GPH.
- Fuel pressure rises on a 1:1 ratio when referencing boost.
- All ports are 3/8" NPT, with one inlet and three outlets on the main body and one return port on the bottom.
- Bypass design provides the ultimate, dynamic fuel pressure control.

All 3-Port #17731 \$179.95/ea.
 All 3-Port, Platinum #17732 \$198.95/ea.

AEROMOTIVE EFI BYPASS REGULATOR AND FITTING KIT WITH GAUGE

This EFI Bypass Regulator kit encompasses features and benefits only found on Aeromotive regulators in a new smaller and lighter package. Capable of supporting applications up to 1000 HP, the EFI Bypass Regulator can handle high-flow EFI fuel pumps and the most aggressive street machines; especially those looking for a cleaner, lighter solution where performance is critical or where space is a premium. This Kit comes with fittings and gauge to simplify installation.

- Base pressure adjustable from 30-70 PSI
- Fuel pressure rises on a 1:1 ratio with boost
- Provides two ORB-06 inlet/outlet ports and one ORB-06 return port
- 1/8" NPT gauge port
- Vacuum boost port
- CNC-Machined 6061 T6 billet aluminum construction
- Stainless steel mounting bracket

All..... #17728..... \$221.95/kit



AEROMOTIVE CARBURETOR ADJUSTMENT REGULATORS, 2-PORT

Specifically designed for carbureted street or racing engines, these adjustable regulators offer higher flow, quicker response and less pressure creep than competing two-port designs. Ideal for dedicated nitrous applications. These regulators are used by many of the NASCAR® teams. Platinum series features a mirror nickel show car finish. Features Include: Adjustable from 5-12 PSI, 1/8" NPT gauge port, Regulators re-seat after the carburetor needle shuts down, preventing pressure creep, includes mounting bracket, and part #17729 provides 3/8" NPT inlet and outlet ports.

All..... #17729..... \$117.95/ea.
 All Platinum Series #17730..... \$129.95/ea.



AEROMOTIVE FUEL PRESSURE GAUGES

Both Aeromotive high and low pressure versions feature a unique pressure equalization pin that permits you to equalize internal gauge case pressure to atmosphere, restoring accuracy, regardless of operating temperature.

All 0-15 PSI, 1/8 NPT #18027 \$47.95/ea.
 All 0-100 PSI, 1/8 NPT #18028 \$47.95/ea.

**AEROMOTIVE A1000
CARB BYPASS
REGULATOR**

The A1000 bypass regulator was designed for use with the Aeromotive A1000 Fuel Pump or similar style EFI pumps in a carbureted application. This regulator is perfect for naturally aspirated or 'blow-through' super-charged engines. Ideal for converting from fuel injection to carburetion using the stock, in-tank pump. It features (1) ORB-10 inlet and (1) ORB-8 return port, (2) ORB-6 outlet ports and a dedicated 1/8" NPT fuel pressure gauge port. Adjustable for pressure ratings between 3-15 PSI.
All..... #18996..... \$209.95/ea.



**AEROMOTIVE GEN2
A1000 EFI REGULATOR**

This A1000 fuel pump regulator is a high Performance, adjustable EFI regulator designed for medium to high horsepower applications. It features Aeromotive's high-flow design, superb pressure control, legendary durability, (2) ORB-6 inlet and outlet ports, (1) ORB-6 return port and a dedicated 1/8" NPT fuel pressure gauge port. Adjustable for pressure ratings between 40 & 70 PSI it is also compatible with diesel, gas, ethanol and methanol.



All..... #18995..... \$210.95/ea.

AEROMOTIVE REGULATOR FITTINGS

Contains three AN-06 to AN-06 male flare fittings.

All -6AN #17733..... \$49.95/kit



AEROMOTIVE X1 EFI REGULATOR

From carbureted to EFI pressures, naturally aspirated or forced induction, the X1 is designed to span the entire range of applications providing dependable fuel pressure regulation. Making the change from carburetor to EFO or EFI to carburetor?? There is no longer the need to purchase a new regulator. Simply utilize one of three conversion kits (Sold separately) to match the operating range required for your engine. Utilizes a larger (3) -8AN inlet/outlet/return ports, 1/8" NPT gauge port and 1:1 ratio boost reference port for easy forced induction connection.



1955-57 #19359..... \$216.95/ea.

AEROMOTIVE CARB AND EFI REGULATOR FITTINGS

All -8AN #17734..... \$49.95/kit



#17735



AEROMOTIVE CARBURETOR REGULATOR FITTINGS

Contains three 3/8" to AN-06 male flare adapter fittings.

All -6AN #17735..... \$29.95/kit

Contains three 3/8" to AN-08 male flare adapter fittings.

All -8AN #17736..... \$29.95/kit



O-RING BOSS PORT PLUG

**1955-57 ORB-8
..... #19360.\$12.95/ea.**



ORB TO AN FLARE FITTINGS

**1955-57 ORB-8 to 6
..... #19361.\$19.95/ea.
1955-57 ORB-8 to 8
..... #19362.\$19.95/ea.**



INTAKE MANIFOLDS

EDELBROCK PERFORMER RPM INTAKE MANIFOLDS

Performer RPM is a step up the performance ladder for your street machine. The Performer RPM Air-Gap series have an open space that separates the runners from the hot engine oil resulting in cooler manifold runners and more power. Order the Vortec version if you are running Vortec heads. 1500-6500 power range. Use with square bore carburetors only.

1955-86 SB, Performer RPM, Cast.....	#13118.....	\$217.95/ea.
1955-86 SB, Performer RPM, Endurashine.....	#13361.....	\$348.95/ea.
1955-86 SB, Performer RPM Air-Gap, Cast.....	#13116.....	\$278.95/ea.
1955-86 SB, Performer RPM Air-Gap, Endurashine.....	#13360.....	\$462.95/ea.
All BB, Performer RPM Air-Gap w/ Oval Port, Cast.....	#13123.....	\$325.95/ea.
All BB, Performer RPM Air-Gap w/ Oval Port, Endurashine.....	#13364.....	\$559.95/ea.
All Vortec Heads Performer RPM Air-Gap, Cast.....	#13119.....	\$345.95/ea.
All Vortec, Performer RPM, Endurashine.....	#14733.....	\$379.95/ea.



EDELBROCK PERFORMER LS3 CARBURETOR INTAKE MANIFOLD

Designed for Gen IV engines with LS3, L92 and L76 rectangular port cylinder heads. The Performer RPM LS3 manifold is ideal for anybody looking to build a carbureted LS3 or LS2 engine with an operating range between 1,500 - 6,500 rpm. It allows the use of a carburetor on these originally computer-controlled engines, offering maximum power and a broad torque curve. It features a high-rise dual-plane design combined with a plenum that has been optimized for square-bore carburetors. Performer RPM LS3 includes a provision for mounting an MSD Ignition Timing Control Module, part #17631, including passages for routing the coil wire harness, for a clean look. A special throttle and transmission bracket that works with 700R-4, 200-4R and Turbo 350 transmissions is also included, making this an easy retro-fit for your classic.

All..... #18136..... \$383.95/ea.



EDELBROCK PERFORMER RPM LS1 INTAKE MANIFOLD

This powerful manifold will fit the LS1 and LS6 as well as the LM-7 (5.3L), LR4 (4.8L) and the truck LQ4 (6.0L) Gen III engines. It allows the use of a carburetor on these computer controlled engines and includes a MSD timing control module that works with the OE sensors to fire the coil-on-plug system. Kit also includes a special throttle and transmission bracket that works with 700R4, 200-4R and TH350 transmissions making the engine an easy retro-fit for your classic.

1997-Up with Timing Module, LS1

..... #13700... \$1054.95/ea.



EDELBRÖCK PERFORMER INTAKE MANIFOLDS

The Performer is one of the best intakes for street performance and Danchuk #13112 has the provision for an original oil tube. Power range is from idle to 5500 RPM. Use with a spread bore or square bore carburetor. Order Vortec version if you are running Vortec heads. Big Blocks will not fit "tall blocks".

1955-86 SB, Cast.....	#13112.....	\$182.95/ea.
1955-86 BB, Oval, Cast.....	#13121.....	\$287.95/ea.
All SB, Vortec, Cast.....	#13114.....	\$255.95/ea.
All SB, Vortec, Endurashine.....	#13359.....	\$384.95/ea.



Fuel

INTAKE MANIFOLDS



EDELBRÖCK PERFORMER EPS INTAKE MANIFOLDS

This newest version of the Performer manifold has ports that are better tuned to give you a gain of up to 5HP and 9 ft./lbs. of torque over the original Performer in the 3000-4500 RPM range. Power range is from idle to 5500 RPM. Use with square bore carburetors only.

1955-86 SB, Cast.....	#13110.....	\$145.95/ea.
1955-86 SB, Endurashine.....	#13358.....	\$335.95/ea.
1955-86 SB w/ Filler Tube/Breather, Cast.....	#14990.....	\$243.95/ea.
1955-86 SB w/ Filler Tube/Breather, Endurashine.....	#14991.....	\$417.95/ea.
1996-Up SB Vortec, Endurashine.....	#15294.....	\$383.95/ea.
All SB Vortec, Cast.....	#14732.....	\$268.95/ea.



EDELBRÖCK PERFORMER AIR-GAP INTAKE MANIFOLDS

Performer Air Gap manifolds are a dual-plane low-rise design like the Performer series with the addition of Edelbrock's patented Air Gap and is designed for all 1955-86 262-400 c.i.d. small blocks. The Air Gap design features an open air space that separates the runners from the hot engine oil resulting in cooler runners and more power. High velocity runners deliver excellent throttle response in the idle to 5500 PRM power range and the Endurashine finish gives you a brilliant shine that won't oxidize, fade or discolor like chromed or polished manifolds. No provision for exhaust heated chokes or exhaust crossover. Use with spread bore or square bore carburetors.

1955-86 SB, Cast.....	#13115.....	\$289.95/ea.
1955-86 SB, Endurashine.....	#16525.....	\$442.95/ea.

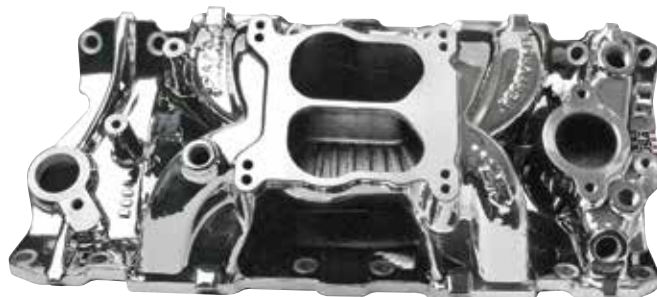

SMALL BLOCK MANIFOLDS AND CARBURETOR KITS

It's easy to upgrade your induction system with the best combination of Edelbrock proven performance and looks in a single box. These kits include: an Edelbrock manifold and a performer or Thunder AVS series carburetor with Standard finish to suit your engines air and fuel requirements, a chrome fuel inlet, high quality Edelbrock intake gasket set, intake bolt set and carburetor stud kit.



1957-86 Performer EPS, 600 Carburetor	#17165.....	\$556.95/kit
1957-86 Performer Air Gap, 600 Carburetor	#17166.....	\$695.95/kit
1957-86 Performer RPM, AVS 800 Carburetor	#17167.....	\$725.95/kit
1957-86 RPM Air Gap, AVS 800 Carburetor	#17168.....	\$782.95/kit

SMALL BLOCK MANIFOLD WITH INSTALL KITS

Edelbrock has packaged all the necessary components to replace your stock iron intake manifold. These kits include an Edelbrock aluminum intake manifold, intake gasket set, carburetor base gasket, RTV sealant, intake bolts and carburetor studs for an all-in-one-box installation for your classic Chevy. Get better performance from a simple manifold replacement kit.



1957-86 Performer EPS w/ Install Kit	#17162.....	\$239.95/kit
1957-86 Performer RPM w/ Install Kit	#17163.....	\$269.95/kit
1957-86 RPM Air Gap w/ Install Kit	#17164.....	\$322.95/kit

EDELBRUCK THUNDER SERIES CARBURETORS

Thunder AVS (Air Valve Secondary) Carburetors are designed to deliver optimum performance. The quick-tune adjustable valve secondary allows you to adjust the secondaries to suit a variety of needs with simple tools, no springs required, can be configured for either single or dual feed. Fits square bore pattern manifolds.



All AVS, 650 CFM, Electric Choke (Shown)	#13076	\$355.95/ea.
All AVS, 800 CFM, Electric Choke	#13077	\$476.95/ea.
All AVS, 650 CFM, Electric Choke, Endurashine	#14052.....	\$561.95/ea.
All AVS, 500 CFM, Electric Choke, Endurashine (Shown)	#14054.....	\$514.95/ea.
All AVS, 500 CFM, Manual Choke, Endurashine	#14055.....	\$514.95/ea.

EDELBROCK PERFORMER SERIES CARBURETORS

Edelbrock Performer Series carburetors are designed to handle the rigors of daily driving while delivering consistent reliable street performance from day to day. They use metering rods to transition between circuits which means they are unaffected by engine backfires as they have no power valve to blow out, and the rods can be changed in seconds for easy tuning. And they STAY tuned so performance remains constant day in and day out. Manual choke models are calibrated for optimum performance, the electric choke versions are calibrated for optimum fuel economy. Fits square bore manifolds. Not legal for sale or use on pollution controlled vehicles.



#13078

All 500 CFM, Electric Choke, Non-EGR.....	#14720.....	\$401.95/ea.
All 500 CFM, Manual Choke, Non-EGR	#14721.....	\$346.95/ea.
All 600 CFM, Manual Choke (Shown).....	#13078.....	\$319.95/ea.
All 600 CFM, Electric Choke.....	#13079.....	\$356.95/ea.
All 600 CFM, Manual Choke, Endurashine.....	#15678.....	\$457.95/ea.
All 600 CFM, Electric Choke, Endurashine	#14053.....	\$525.95/ea.
All 750 CFM, Electric Choke.....	#13080.....	\$393.95/ea.
All 750 CFM, Manual Choke	#13081.....	\$379.95/ea.



EDELBROCK PERFORMER CARBURETOR WITH BLACK FINISH

Edelbrock's Performer Series carburetor is now available with a black powder coated finish with bright silver hardware, giving you a look that will set you apart from the crowd. Equipped with an electric choke for better cold starts.

All 600CFM w/ Electric Choke #16939..... \$433.95/ea.

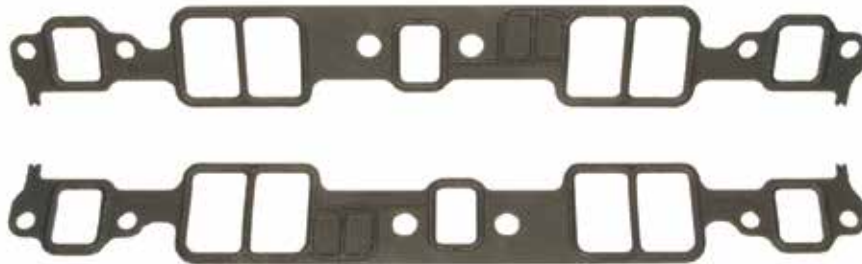

EDELBROCK INTAKE MANIFOLD GASKETS

Edelbrock gaskets feature an embossed silicone bead around the ports for a clean positive seal. End seals not included. We recommend using RTV silicone.

All SB exc. Vortec or E-Tec Heads #13106..... \$18.95/set



ACCELERATOR PUMP ASSEMBLIES

All 500-650 CFM Performer Carburetors	#13234.....	\$13.95/set
All 750 CFM Performer Carburetors	#13235.....	\$10.95/set

EDELBROCK RPM DUAL QUAD AIR-GAP MANIFOLD AND CARBURETOR KITS

Edelbrock's RPM Dual Quad Air Gap manifold and carburetor kit provides everything needed to convert from single carburetor to dual-quad set up for small block Chevy's. Kit includes the new Dual Quad Air Gap manifold, two Thunder AVS 500cfm carburetors (one manual, one electric choke), high tech progressive linkage, fuel line and intake gaskets.

1955-86 SB, Endurashine	#14056.....	\$1641.95/kit
1986-95 SB, Endurashine	#14057.....	\$1565.95/kit
All BB, Endurashine	#15131.....	\$1697.95/kit



EDELBROCK SINGLE QUAD MANIFOLD AND CARBURETOR KITS WITH ENDURASHINE FINISH

Edelbrock's Single-Quad manifold and carburetor kits with Endurashine finish provide you with everything needed to install an aluminum manifold and carburetor on your classic Chevy. Each kit includes: Intake manifold and either Performer or Thunder AVS carburetor with Endurashine finish, fuel line, Gasgacinch, intake bolts and gaskets.

1957-86 SB, Performer EPS w/ Performer 600	#14293.....	\$830.95/kit
1957-86 SB, Performer Air Gap w/ Performer 600	#14294.....	\$895.95/kit
1957-86 SB, Performer RPM Air Gap w/ Thunder AVS 800	#14295.....	\$1004.95/kit
All SB, Vortec Performer w/ Thunder AVS 650	#14297.....	\$884.95/kit
All SB, Vortec RPM Performer Air Gap w/ Thunder AVS 800	#14299.....	\$1059.95/kit
All BB, Oval Port Performer, w/ Thunder 800	#14300.....	\$1014.95/kit
All BB, Oval Port RPM Air Gap, w/ Thunder AVS 800, Performer	#14302.....	\$1050.95/kit



EDELBROCK CARBURETOR BASE GASKETS	
All.....	#14731..... \$10.95/pr.



TAPERED PORT CARB ADAPTER

All Large Square Bore to Small Square Bore, 4BC
 #13424..... \$33.95/ea.



EDELBROCK CARBURETOR ADAPTER PLATE

Part #13353 mounts to original Q-Jet manifold.
 All Spread Bore to Square Bore, .850" Thick
 #13353..... \$25.95/ea.

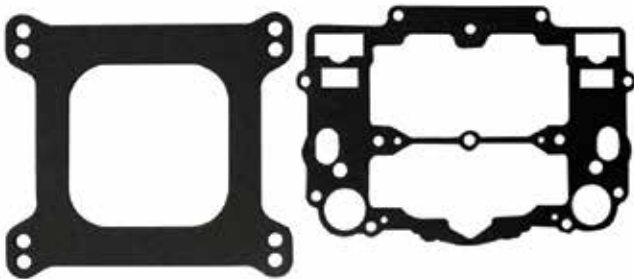

HEAT INSULATOR CARBURETOR GASKETS

Heat insulator gaskets help prevent fuel percolation by insulating the carburetor from excess engine heat. Use divided version for dual plane and open for open plane manifolds.
 All Open Bore #13698..... \$22.95/ea.
 All Divided Bore..... #13699..... \$20.95/ea.



EDELBROCK CARBURETOR REBUILDING KIT

For all square bore carburetors.
 All..... #13231..... \$40.95/ea.

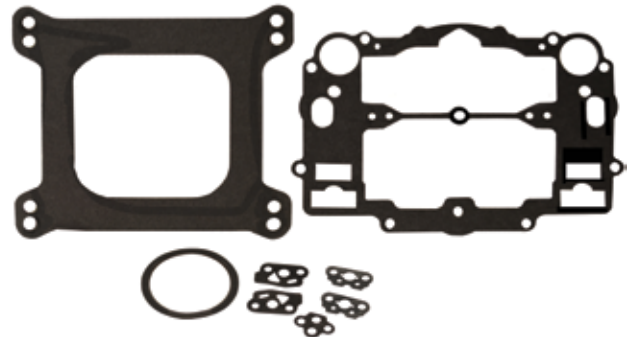

EDELBROCK CARBURETOR-TO-MANIFOLD AND AIRHORN GASKETS

All..... #14730..... \$13.95/set

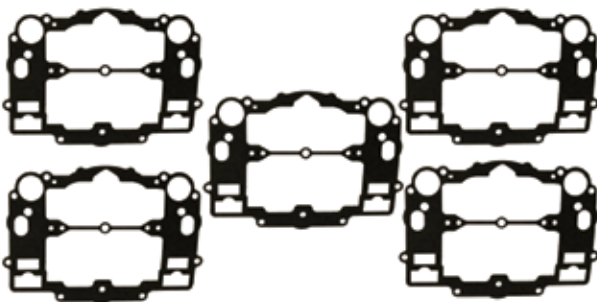

EDELBROCK CARBURETOR AIRHORN AND BASE GASKETS

All 5-Piece #17225..... \$16.95/ea.

EDELBROCK CARBURETOR CALIBRATION KITS

All calibration kits include an assortment of metering rods and jets, one pair of metering rod retaining springs and a complete assortment of step-up springs.



- EDL #1486 #17216.....\$63.95/kit
- EDL #1479 #17217.....\$69.95/kit
- EDL #1487 #17218.....\$46.95/kit
- EDL #1480 #17219.....\$65.95/kit
- EDL #1489 #17220.....\$53.95/kit
- EDL #1840 #17221.....\$60.95/kit
- EDL #1841 #17222.....\$75.95/kit
- EDL #1842 #17223.....\$61.95/kit



EDELBROCK THROTTLE SOLENOID AND BRACKET

All..... #13356.....\$176.95/kit



EDELBROCK HARDENED STEEL PUSHRODS

Part #13145 is for use with Performer RPM heads and is + .100 longer than stock.

All SB, 5/16" Diameter #13145..... \$136.95/set



EDELBROCK STEP UP SPRING ASSIST

Step up springs are key to fine tuning the "Power Mode" of your Edelbrock carburetor to your specific needs. Includes 3" Hg (blue), 4" Hg (yellow), 5" Hg (orange), 7" Hg (pink) and 8" Hg (plain) springs.

All 5 Pairs of Springs #13233..... \$9.95/set



EDELBROCK CYLINDER HEAD GASKET SET

All SB..... #13140..... \$99.95/ea.



EDELBROCK AND CARTER AFB CARB BANJO FITTING

All 3/8" #18673..... \$11.95/ea.



EDELBROCK TRIPLE DEUCE FUEL LOG KIT

This fuel log kit is an exact replica of the original design used by Vic Senior in the 1950's. Kit includes black neoprene hose, Corbin style hose clamps, barb fittings, a pipe plug and a period correct Edelbrock decal for the right look.

All..... #16937.....\$91.95/kit

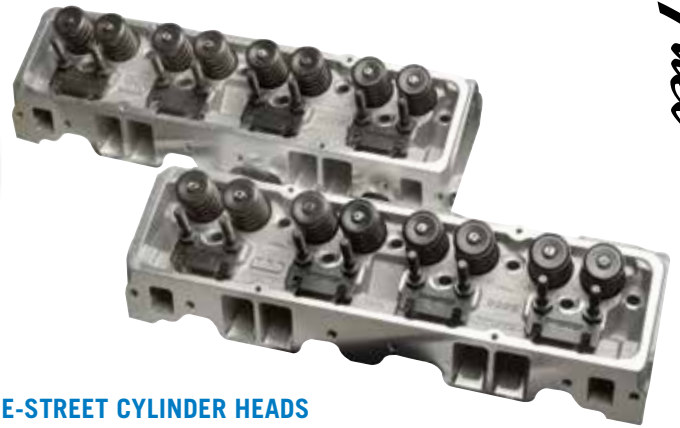

EDELBROCK E-210 E-STREET CYLINDER HEADS

The E-210 cylinder head for small-block Chevy engines provides race-level performance while maintaining full compatibility with OEM equipment. It features larger runners for increased airflow, revised exhaust ports and larger diameter springs for higher lift camshafts, making them ideal for a spec series racer and larger displacement engines. The exhaust port flange is in the stock location to allow for the use of off-the-shelf headers and hardware, while the enlarged valves and ports support the power needed to compete at engine speeds of up to 6500 rpm. The E-210 cylinder head is capable of supporting more than 500 naturally aspirated horsepower, and even more in forced induction applications. Sold in pairs. **Made in the USA.** For hydraulic flat tappet and Hydraulic Roller applications.

All Hyd Flat Tappet..... #16475....\$1362.95/pr.
All Solid or Roller Tappet #16476....\$1420.95/pr.

E-STREET CYLINDER HEADS

E-Street cylinder heads are an all new line of Edelbrock heads designed for entry-level street performance engines, ideal for operating in the idle to 5,500 RPM range. Manufactured in the USA, by Edelbrock, these heads feature A356 aluminum castings that are heat treated to T-6 spec for superior casting strength and quality. Their modern combustion chamber designs improve the combustion process and larger than stock intake and exhaust ports move more air through your engine. These features improve an engine's efficiency, resulting in more horsepower and torque and improved mileage potential.

All 70CC, 86 & Earlier SB #15638.....\$950.95/pr.
All 64CC, 86 & Earlier SB #15639.....\$969.95/pr.

EDELBROCK PERFORMER RPM CYLINDER HEADS

Designed for emission legal 302-400 c.i. engines. These heads are straight plug, have 2.02 intake valves, 1.60 exhaust valves, 64 or 70 CC combustion chambers and made 420HP with the Performer RPM power package. Be sure to order head gaskets and the correct head bolt kit. Hardened pushrods are required. RPM series heads do not have an exhaust crossover. **Made in the USA.**

1955-57 SB w/ Straight Plugs, 70 CC
 #13128..... \$736.95/ea.
1955-57 SB w/ Straight Plugs, 64 CC
 #13129..... \$713.95/ea.

EDELBROCK PERFORMER SMALL BLOCK CYLINDER HEADS

Designed for emission legal 302-400 c.i. engines featuring an exhaust crossover for emissions compatibility. Performer heads provide outstanding street performance. Be sure to order head gaskets and the correct head bolt kit. Hardened pushrods are required. **Made in the USA.**

All 70 CC..... #13130..... \$825.95/ea.
All 64 CC..... #13131..... \$831.95/ea.



EDELBROCK CYLINDER HEAD BOLTS

Edelbrock head bolt kits contain a complete set of the highest quality head bolts and washers available. A must have when switching from cast iron to aluminum heads.

All SB..... #13138..... \$153.95/kit



EDELBROCK FUEL LINES

All Single Feed w/ Polished Aluminum Filter, 40 Micron.....	#13089.....	\$40.95/ea.
All Single Feed w/ Blue Anodized Filter, 40 Micron.....	#13090.....	\$38.95/ea.
All Single Feed w/ 3/8" Barbed Outlet, w/o Filter.....	#13091.....	\$24.95/ea.
All Dual Feed w/ Blue Anodized Filter, 40 Micron.....	#13092.....	\$94.95/ea.
All Dual Feed w/ Polished Aluminum Filter, 40 Micron	#13093.....	\$84.95/ea.
All Dual Feed w/ 3/8" Barbed Outlet, w/o Filter.....	#13094.....	\$81.95/ea.



EDELBROCK HOSE KITS

All Fuel Pump to Regulator, 22", Braided Steel, SB*	#13102.....	\$62.95/kit
All Fuel Pump to Regulator, 27", Braided Steel, BB*	#13103.....	\$65.95/kit
All Fuel Pump to Carburetor, Braided Steel, SB**	#13104.....	\$39.95/kit
All Fuel Pump to Carburetor, Braided Steel, BB*	#13105.....	\$44.95/kit

*Note: For use with Edelbrock single and dual feed fuel line kits.

** Note: Goes from pump to filter assemblies.



EDELBROCK PRO-CLASSIC FUEL LINES

All SB, Black	#14728.....	\$39.95/kit
All BB, Black	#14729.....	\$54.95/kit



EDELBROCK FUEL FILTERS

Filters use -6AN fittings and have replaceable elements (40 microns), part #13088.

All High Flow, 40 Micron, Polished Aluminum	#13086.....	\$32.95/ea.
All High Flow, 40 Micron, Blue Anodized	#13087.....	\$29.95/ea.

EDELBROCK REPLACEMENT FUEL FILTER ELEMENT

For use with filters #13086 and #13087.

All 40 Micron	#13088.....	\$6.95/ea.
---------------------	-------------	------------



EDELBROCK ELECTRIC CHOKE KIT

This kit has everything you need to convert your manual choke Performer Series carburetor to an all season reliable electric choke.

All..... #13232..... \$74.95/kit



EDELBROCK RPM SERIES FUEL PUMPS

RPM Street Series billet aluminum mechanical fuel pumps are for high performance street applications. The 3/8" inlet and outlet offers increased flow over most other street fuel pumps, and the base clock position can be rotated to allow for various fuel line configurations. RPM Series fuel pumps will produce 6 psi and flow 110 gph. You will not need a fuel pressure regulator with this pump and it is designed for use with gasoline only.

All SB..... #13095..... \$135.95/ea.

All BB..... #13096..... \$152.95/ea.

EDELBROCK VICTOR SERIES FUEL PUMPS

Victor Series billet aluminum mechanical fuel pumps are for high performance racing applications. The 5/8" -18 inlet and outlet come with -8AN fittings installed to provide increased flow over street fuel pumps, and the base clock position can be rotated to allow for various fuel line configurations.

These pumps include a variety of additional inlet/outlet fittings including -6AN, inverted flare and 3/8" NPT, plus a copper crush washer for a leak-proof connection. Victor fuel pumps will produce 8.5-9 psi and will require the use of a fuel pressure regulator, such as Danchuk # 13100 shown on page 344. They will work with both gasoline and alcohol. Victor Series requires a fuel pressure regulator.

All SB..... #13097..... \$132.95/ea.

All BB..... #13098..... \$139.95/ea.

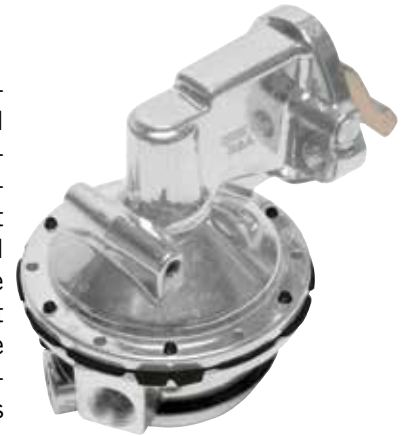

QUIET-FLO FUEL PUMPS

This pump features an aluminum housing with high quality internals that makes it durable but 4 to 14 dB quieter than the competition. Part #13350 requires no regulator.

All 120 GPH @ 6.5 PSI #13350..... \$209.95/ea.



WEATHERPROOF FUEL PUMP RELAY KIT

All..... #14614..... \$59.95/ea.



EDELBROCK UNIVERSAL EFI SUMP FUEL KIT

This Universal Sump Fuel Kit is designed to provide the necessary high fuel pressure required for EFI applications in vehicles equipped with an existing low pressure carbureted fuel system. This is a complete self-contained system that can be easily installed under the hood. The unique design of this system allows it to deliver a constant fuel pressure with no fuel return line, external fuel pressure regulator or fuel tank modifications. It is compatible with the existing factory fuel tank and pump, and is ideal for use with various aftermarket EFI systems and with many popular engine swap applications that require constant 35-90 psi fuel pressure. This Fuel Sump Kit features a new compact design that is adjustable from 35 to 90 psi and includes a vacuum reference port. This kit includes a durable molded, lightweight plastic fuel sump tank with high pressure fuel pump installed, wiring harness, universal mounting brackets, hose, fittings and all of the necessary hardware for installation.



All 105 GPH #18775..... \$499.95/kit



EDELBROCK CARBURETOR FUEL PRESSURE REGULATORS

- All 160 GPH, 5-10 PSI, Red..... #18463.....\$97.95/pr.
- All 160 GPH, 5-10 PSI, Blue..... #18464.....\$100.95/pr.
- All 160 GPH, 5-10 PSI, Black..... #18465.....\$97.95/pr.



EDELBROCK FUEL PRESSURE REGULATOR

All Adjustable, Regulator Only #13100..... \$79.95/ea.



QUICK DISCONNECT EFI FITTINGS

Use these fittings with part #17964 to convert the OE fittings to -6AN for easy hookup.

- All -6AN Male x 3/8 Female..... #17965..... \$12.95/ea.
- All -6AN Male x 3/16 Female..... #17966..... \$11.95/ea.
- All -6AN Male x 3/8 Male..... #17967..... \$7.95/ea.



LS ENGINE FUEL FILTER/REGULATOR

Make your LS engine swap easier with the fuel filter regulator combination. It can be used on other EFI applications that require 50 PSI. Be sure to order the quick disconnect fittings part #17965, #17966 or #17967 to make set up a breeze.

All..... #17964..... \$54.95/ea.



EDELBROCK PRO FLO 4 EFI KITS

Edelbrock Pro-Flo 4 EFI systems are equipped with the latest technology and features. The system comes complete with a traditional 4150-style single plane intake manifold and 29 lb/hr injectors capable of 550 HP. Also included is a plug and play single connection distributor designed to work specifically with Pro-Flo 4 and a made in the USA fully terminated high-quality harness with clearly labeled connections to ensure a hassle-free installation. Pro-Flo 4 EFI systems feature an all-new ECU with a faster processor, a water proof design and measures half the depth of the previous ECU. The key to the system is the Edelbrock exclusive E-Tuner 4 app with dyno developed base calibrations. The E-Tuner 4 app uses a Bluetooth wireless connection to communicate with the ECU's self-learning capability to continually adjust the calibration to get maximum performance. The E-Tuner 4 features a simple and easy to use setup wizard to help you get started and best of all, the E-Tuner 4 app allows you to use your personal Android based smart phone or tablet. Multiple dash displays are included to allow you to monitor engine vitals from your Android smart phone or tablet. No computer is necessary.

All 86-Earlier Small Block, 550HP.....	#19063.....	\$1795.95/kit
All 86-Earlier Small Block, 550HP, w/o Tablet.....	#19064.....	\$1695.95/kit
All BB Oval Port, 625HP.....	#19065.....	\$1895.95/kit
All BB Oval Port, 625HP, w/o Tablet.....	#19066.....	\$1795.95/kit
All LS Gen 3/4, Cathedral Port.....	#19067.....	\$1895.95/kit
All LS Gen 3/4, Cathedral Port, w/o Tablet.....	#19068.....	\$1795.95/kit
All LS Gen 3/4, Rectangle Port.....	#19069.....	\$1895.95/kit
All LS Gen 3/4, Rectangle Port, w/o Tablet.....	#19070.....	\$1795.95/kit

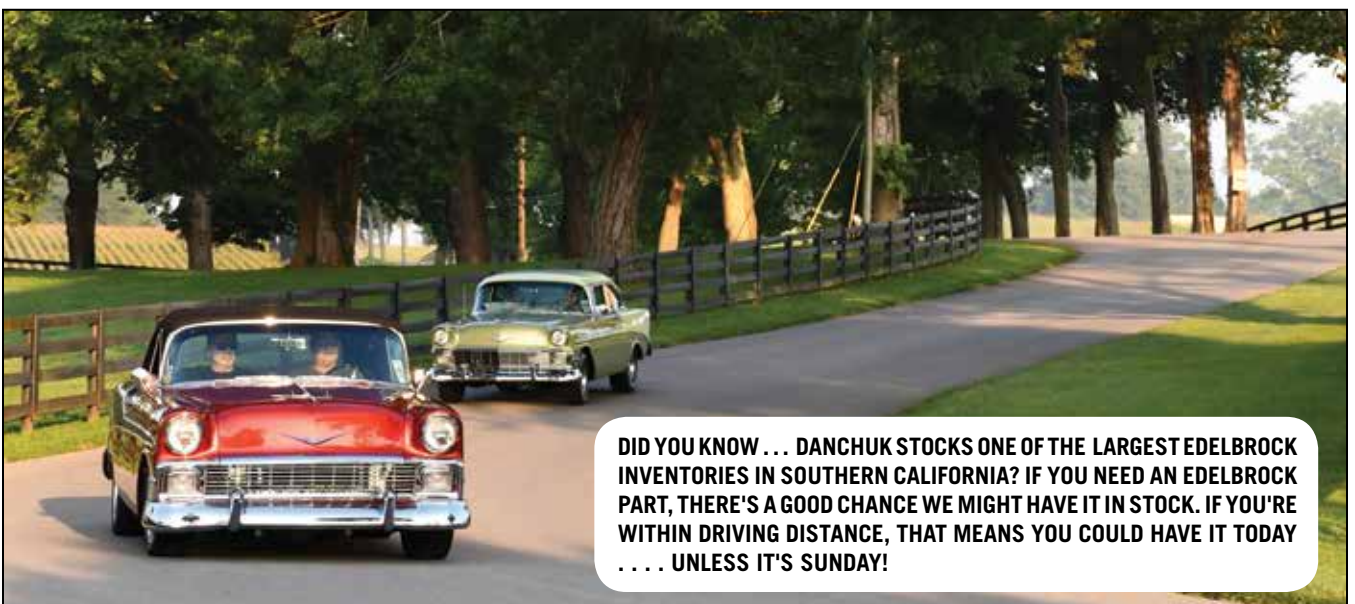

DID YOU KNOW . . . DANCHUK STOCKS ONE OF THE LARGEST EDELBROCK INVENTORIES IN SOUTHERN CALIFORNIA? IF YOU NEED AN EDELBROCK PART, THERE'S A GOOD CHANCE WE MIGHT HAVE IT IN STOCK. IF YOU'RE WITHIN DRIVING DISTANCE, THAT MEANS YOU COULD HAVE IT TODAY . . . UNLESS IT'S SUNDAY!



EDELBROCK EFI RETURN STYLE FUEL SYSTEM

Return Style Fuel Kits include everything needed to upgrade a carbureted fuel system to a high pressure EFI system, excluding the fuel tank. This kit is a return-style and will complete the fuel system loop by returning unused fuel to the tank. Kit includes a 57 GPH (215 liter/hr) fuel pump, adjustable regulator, filter, Russell Twist-Lok hose, hose ends, mounting brackets and hardware. A baffled fuel tank is recommended to prevent fuel starvation. This system is rated for engines up to 600 HP, when used with an E-Street EFI system.

All..... #17828..... \$586.95/ea.

**OE FUEL INJECTION
MAIN LINE FUEL
SHUT OFF SOLENOID**

This electric fuel shut-off solenoid is a safety feature that protects against hydraulic compression damage. The solenoid is aircraft style for gasoline usage and is installed under the plenum. Necessary for all 1957-1958 units and 1959 4900 and 7300 units. It is recommended you add one of these on all fuel injection units.

1957-62 #18944..... \$89.95/ea.



REPLACEMENT FUEL INJECTION FUEL MODULE

This is a complete replacement fuel module for the Danchuk #14947 and #14948 OE style performance fuel injection gas tanks. You get the hangar and sender assemblies along with the strainer, float and wiring harness. You will need a fuel pressure regulator to run this pump, sold separately.

1955-57 #18771..... \$249.95/ea.



REPLACEMENT FUEL INJECTION FUEL PUMP

For tanks #14947 or #14948.

All..... #17834..... \$49.95/ea.



Photo courtesy of GERTMAN2000

MSD ATOMIC EFI MASTER KIT WITH PUMP

The Atomic EFI Master kit includes every component you need to complete an EFI conversion. Kit includes: throttle body, power module, wide band O2 sensor, handheld programmer and a fuel pump that supports up to 525HP. Return line not required.



All..... #16902..... \$2477.95/kit



MSD ATOMIC EFI THROTTLE BODY KIT

If you have a car that already uses a high-pressure fuel pump with a return line then this kit provides the parts to convert to Atomic Power. Kit includes: throttle body, power module, wide band O2 sensor and a handheld programmer.

All..... #16903..... \$2214.95/kit



MSD ATOMIC EFI HIGH HP FUEL PUMP KIT

For engines from 525-650HP. Kit includes PWM fuel pump, pre and post filters, 15 feet of 3/8-inch fuel line and mounting hardware.

All..... #16904..... \$624.95/kit



MSD ATOMIC EFI INSTALLATION KIT

The MSD Atomic EFI install kit for LS1/6 is an add on kit which provides the wiring necessary to install the EFI Master Kit for LS2/3 on any LS1/6 application. Supplied in the kit are the different brackets for the rail assemblies as well as the different injector connectors to adapt the LS2/3 master kit to the LS1/6 intake manifold.

All LS1/LS6 #17812..... \$189.95/kit



Photo courtesy of GERTMAN2000

PAINLESS
Performance Products

FUEL INJECTION

FUEL INJECTION WIRE HARNESSES

Those who choose to run the factory ECM will appreciate the simplicity of a Painless fuel injection wire harness. You can try to make the stock harness work, but why complicate things? Painless has worked out all the potential problems, so all you have to do is follow the instructions and you're on your way. Every wire is labeled for ease of installation.



2000-2002 Gen III V8 w/ Electric Throttle.....	#15114.....	\$899.95/ea.
2003-06 4.8-6.0L.....	#17419.....	\$749.95/kit
2006-08 LS2/LS3/LS7, w/ 4L60E/65E	#17421.....	\$799.95/kit
2007-Up Gen IV w/ 4L65-85E Transmission	#17422.....	\$856.95/kit



MSD ATOMIC LS COIL COVER KITS

Clean up your LS engine swap with these coil-covers from MSD. Designed to work with MSD's Atomic LS EFI kits, but can be made to work along with minor modifications.

All Red.....	#17807.....	\$159.95/kit
All Black.....	#17808.....	\$175.95/kit
All Unfinished	#17809.....	\$175.95/kit



1957 FUEL INJECTION VENT LINE

This vent line runs from the fuel meter to the air cleaner.

1957.....	#2192.....	\$19.95/ea.
-----------	------------	-------------



1957 FUEL INJECTION FUEL FILTER BRACKET STUDS

These are the two special studs with threaded heads that screw into the intake so you can attach the fuel filter on factory Fuel Injection cars. Comes complete with the nuts and star style lock washer. Sold as a pair.

1957 with Nuts.....	#18933.....	\$24.95/pr.
---------------------	-------------	-------------



1957 FUEL INJECTION AIR CLEANER BRACKET

This is the bracket that installs between the center bolt on the fuel injection air cleaner assembly center bolt on the inside and the water outlet bolt that supports the fuel injection air cleaner.

1957 F.I.	#1301.....	\$15.95/ea.
----------------	------------	-------------



Note: All exhaust systems on this page are drop shipped from the supplier. Due to the size of the exhaust kits, shipping charges are approximately \$175.00 and available to ship to the contiguous 48 US states ONLY. No shipping to Alaska or Hawaii or international. ALL EXHAUST SYSTEMS ON THIS PAGE CAN TAKE 4-6 WEEKS DELIVERY.

ALUMINIZED EXHAUST SYSTEMS O/S

Our aluminized exhaust systems are made from heavy 16 gauge steel tubing with mufflers aluminized inside and out. All tailpipes are notched at the tips like the original. System sets include the exhaust header pipes and two header pipe flange gaskets as required. No kinks in bends, no flat spots, and correct fit of pipes every time. The results are a better looking, better performing, better flowing exhaust. All exhaust systems are oversized and will have additional shipping charges. If you've used our shock support upgrade (#950), you can special order any of the exhaust systems "modified" to fit properly. Kits do not include hangers or clamps. These exhaust systems **require** the use of a heat riser valve or heat riser spacer to insure proper fit. See page 359 for exhaust clamp and hanger kits

1955 6-Cyl. Hardtop & Sedan, Single	#2716.....	\$249.95/kit
1955 6-Cyl. Convertible, Single.....	#2717.....	\$249.95/kit
1955 6-Cyl. 6-Passenger Wagon, Single.....	#2718.....	\$249.95/kit
1955 V8 2BC Hardtop & Sedan, Single.....	#2719.....	\$349.95/kit
1955 V8 2BC Convertible, Single	#2720.....	\$349.95/kit
1955 V8 2BC 6-Passenger Wagon, Single	#2721.....	\$349.95/kit
1956 6-Cyl. Hardtop & Sedan, Single	#2725.....	\$249.95/kit
1956 6-Cyl. Convertible, Single.....	#2726.....	\$249.95/kit
1956 6-Cyl. 6-Passenger Wagon, Single.....	#2727.....	\$249.95/kit
1956 V8 2BC Hardtop & Sedan, Single	#2728.....	\$349.95/kit
1956 V8 2BC Convertible, Single	#2729.....	\$349.95/kit
1956 V8 2BC 6-Passenger Wagon, Single	#2730.....	\$349.95/kit
1957 6-Cyl. Hardtop, Sedan, Single.....	#2734.....	\$249.95/kit
1957 6-Cyl. Convertible, Single.....	#2735.....	\$249.95/kit
1957 6-Cyl. 6-Passenger Wagon, Single.....	#2736.....	\$249.95/kit
1957 V8 2BC Hardtop & Sedan, Single.....	#2737.....	\$349.95/kit
1957 V8 2BC Convertible, Single	#2738.....	\$349.95/kit
1957 V8 2BC 6-Passenger Wagon, Single	#2739.....	\$349.95/kit
1955 V8 4BC Hardtop & Sedan, Dual.....	#2722.....	\$499.95/kit
1955 V8 4BC Convertible, Dual	#2723.....	\$499.95/kit
1955 V8 4BC 6-Passenger Wagon, Dual	#2724.....	\$499.95/kit
1956 V8 Dual 4BC HT, Sedan & Convertible, Dual	#10852.....	\$499.95/kit
1956 V8 4BC Hardtop, Sedan & Convertible, Dual	#2731.....	\$499.95/kit
1956 V8 4BC 6-Passenger Wagon, Dual (Shown)	#2733.....	\$499.95/kit
1957 V8 4BC Dual 4BC, F.I., Ht & Sedan, Dual	#2740.....	\$499.95/kit
1957 V8 4BC & F.I. Conv., Dual	#2741.....	\$499.95/kit
1957 V8 4BC Dual 4BC & FI 6-Psngr Wgn. Dual	#2742.....	\$499.95/kit

DUAL TURBO STAINLESS EXHAUST SYSTEMS O/S

Rams horn exhaust systems require the use of a heat riser valve or heat riser spacer to insure proper fit. Steel hanger kit included. Stainless steel hangers not available. All turbo exhaust systems exit straight back and have two-piece tailpipes. All exhaust systems are oversized and will have additional shipping charges.

1955-57 Fits all SB w/ Rams Horn Exhaust Manifold	#2743.....	\$489.95/kit
1955-57 2-1/2" w/ Rams Horn Man., SB Only	#10156.....	\$549.95/kit
1955-57 2-1/2" w/ Header Exhaust, SB or BB	#10157.....	\$499.95/kit

STAINLESS EXHAUST SYSTEMS (NOT SHOWN) O/S

These exhaust systems **require** the use of a heat riser valve or heat riser spacer to insure proper fit.

1955 6-Cyl. Hardtop & Sedan, Single	#2716S.....	\$549.95/kit
1955 6-Cyl. Convertible, Single.....	#2717S.....	\$549.95/kit
1955 6-Cyl. 6-Passenger Wagon, Single.....	#2718S.....	\$549.95/kit
1955 V8 2BC Hardtop & Sedan, Single	#2719S.....	\$724.95/kit
1955 V8 2BC Convertible, Single	#2720S.....	\$724.95/kit
1955 V8 2BC 6-Passenger Wagon, Single	#2721S.....	\$549.95/kit
1956 6-Cyl. Hardtop & Sedan, Single	#2725S.....	\$549.95/kit
1956 6-Cyl. Convertible, Single.....	#2726S.....	\$549.95/kit
1956 6-Cyl. 6-Passenger Wagon, Single.....	#2727S.....	\$549.95/kit
1956 V8 2BC Hardtop & Sedan, Single	#2728S.....	\$724.95/kit
1956 V8 2BC Convertible, Single	#2729S.....	\$724.95/kit
1956 V8 2BC 6-Passenger Wagon, Single	#2730S.....	\$724.95/kit
1957 6-Cyl. Hardtop & Sedan, Single	#2734S.....	\$549.95/kit
1957 6-Cyl. Convertible, Single.....	#2735S.....	\$549.95/kit
1957 6-Cyl. 6-Passenger Wagon, Single.....	#2736S.....	\$549.95/kit
1957 V8 2BC Hardtop & Sedan, Single	#2737S.....	\$724.95/kit
1957 V8 2BC Convertible, Single	#2738S.....	\$724.95/kit
1957 V8 2BC 6-Passenger Wagon, Single	#2739S.....	\$724.95/kit
1955 V8 4BC Hardtop & Sedan, Dual.....	#2722S.....	\$949.95/kit
1955 V8 4BC Convertible, Dual	#2723S.....	\$949.95/kit
1955 V8 4BC 6-Passenger Wagon, Dual	#2724S.....	\$949.95/kit
1956 V8 4BC HT, Sedan & Convertible, Dual	#10852S.....	\$949.95/kit
1956 V8 4BC Hardtop & Sedan, Dual.....	#2731S.....	\$949.95/kit
1956 V8 4BC 6-Passenger Wagon, Dual	#2733S.....	\$949.95/kit
1957 Fits all 1957 V8 4BC, Dual 4BC, Fuel Injection Hardtop & Sedan, Dual.....	#2740S.....	\$1195.95/kit
1957 Fits all 1957 V8 4BC, Fuel Injection Convertible, Dual	#2741S.....	\$1195.95/kit
1957 Fits all 1957 V8 4BC, Dual 4BC, Fuel Injection 6-Passenger Wagon, Dual	#2742S.....	\$1195.95/kit

DUAL TURBO ALUMINIZED EXHAUST SYSTEMS O/S

Just like our original style systems, our turbo dual exhaust systems are made of steel tubing with aluminized mufflers. Includes two exhaust header pipes, 2" balance pipe, two high flow aluminized turbo mufflers and two-piece tailpipes, and hanger kit. Rams horn exhaust systems require the use of a heat riser valve or heat riser spacer to insure proper fit. All turbo exhaust systems exit straight back. Can bolt up to all original styled hangers. (Please note: fits Hardtops and Sedan models only.) Steel hanger kit included. All exhaust systems are oversized and will have additional shipping charges.

1955-57 Fits all SB w/ Rams Horn Exhaust Manifold	#2743.....	\$489.95/kit
1955-57 2-1/2" w/ Rams Horn Man., SB Only	#10156.....	\$549.95/kit
1955-57 2-1/2" w/ Header Exhaust, SB or BB	#10157.....	\$499.95/kit

WARNING! Products on these pages may contain chemicals known to the State Of California to cause cancer and/or birth defects or reproductive harm. www.p65warnings.ca.gov

#12203



#14220



DOUG'S HEADERS **O/S**

Doug's Headers will fit D-port as well as most angle plug heads. They clear 605/500 steering boxes as well as most column shift automatics and feature 3/8" flanges and 16 gauge tubing. Parts #12206-12209 require that the factory transmission side mounts be removed from the frame for clearance, will not work with cast iron powerglides. Big Block applications only work with automatics. Parts #12202 and #12203 will not fit GM Fast Burner head part number 19300955 and sp350, sp383 and ZZ6 engines. Parts #12204 and #12205 will not clear 168-tooth flywheels. Parts #12206 and #12207 have 1-3/4" primaries.

TRI-Y DESIGN SMALL BLOCK HEADERS

1955-57 Bare..... #12202.....\$519.95/pr.
 1955-57 Hot Jet Coated #12203.....\$719.95/pr.

Tube Size	Collector Size	Port Shape	Auto Column Shift	Trans Floor Shift	Std. Column Shift	Trans Floor Shift
1-5/8	2-1/2	OVL	Y	Y	N	Y
Footnotes: 1, 2, 4, 5, 12 & 13						

FULL LENGTH, SMALL BLOCK HEADERS

1955-57 Bare, Auto #12206.....\$519.95/pr.
 1955-57 Hot Jet Coated, Auto..... #12207.....\$719.95/pr.

Tube Size	Collector Size	Port Shape	Auto Column Shift	Trans Floor Shift	Std. Column Shift	Trans Floor Shift
1-3/4	3	SAP	Y	Y	N	Y
Footnotes: 1, 2, 5, 7, 11, 12 & 13						

4-TUBE, SMALL BLOCK HEADERS

1955-57 Bare..... #12204.....\$519.95/pr.
 1955-57 Hot Jet Coated #12205.....\$719.95/pr.

Tube Size	Collector Size	Port Shape	Auto Column Shift	Trans Floor Shift	Std. Column Shift	Trans Floor Shift
1-5/8	2-1/2	OVL	Y	Y	N	Y
Footnotes: 1, 2, 3, 5, 12 & 13						

LS1/LS6 HEADERS

1955-57 Coated #14220.....\$729.95/pr.
 Oxygen sensor bungs welded on collectors.

Tube Size	Collector Size	Port Shape	Auto Column Shift	Trans Floor Shift	Std. Column Shift	Trans Floor Shift
1-7/8	3	SAP	Y	Y	N	N
Footnotes: 2, 3, 8, 9 & 10						

4-TUBE BIG BLOCK HEADERS

1955-57 Bare..... #12208.....\$519.95/pr.
 1955-57 Hot Jet Coated #12209.....\$719.95/pr.

Tube Size	Collector Size	Port Shape	Auto Column Shift	Trans Floor Shift	Std. Column Shift	Trans Floor Shift
2	3-1/2	SAP	Y	Y	N	N
Footnotes: 2, 6, 7, 13 & 14						

**PLEASE CHECK HEADER CLEARANCE BEFORE MOUNTING.
 DAMAGED OR MODIFIED HEADERS CANNOT BE RETURNED.**

NOTE: SEE OUR WEBSITE FOR PHOTOS OF ALL HEADERS.

Footnotes:

1. Fit Angle Plug including Factory GM "Bowtie" Heads.
2. Fits 500/605 Steering Boxes.
3. Shortie Design.
4. Y indicates Tri-Y Design.
5. Fits D-Port and Z24 Motors.
6. Motor in Stock V8 Position Only.
7. Will not fit 4-Speed with factory trans mounts.
8. O² sensor bungs are installed.
9. LS1/LS6 must use LS1 oil pan.
10. Requires street & performance engine adapter.
11. Will not fit with Powerglide.
12. Fits motors in stock and no more than 3/4" forward.
13. Must use V8 Pitman Arm casting Danchuk #13870
14. Must remove factory transmission frame mounts.



#12788



#12789



#12790

PATRIOT HEADERS O/S

Patriot headers feature heavy duty 16-gauge tubing, 3/8" flanges and come with metallic ceramic coating. All the Patriot headers that we offer are designed for **maximum ground clearance** for cars lowered as much as 4". Parts #12788, #12789 and #12790 will clear 605/500 box and will work with all Danchuk side mount kits.

SHORTIE SMALL BLOCK HEADERS

Must use 153-tooth flywheel or mini-starter. Will not fit angle plug heads.

1955-57 Coated #12788.....\$399.95/pr.

Tube Size	Collector Size	Port Shape	Auto Column Shift	Trans Floor Shift	Std. Column Shift	Trans Floor Shift
1-5/8	2-1/2	RD	Y	Y	N	N
Footnotes: 1, 2, 3, 5, 9, 12 & 18						

SHORTIE SMALL BLOCK HEADERS

1955-57 Jet Hot Coated #18840.....\$422.95/pr.

1955-57 Bare..... #18841.....\$245.95/pr.

Tube Size	Collector Size	Port Shape	Auto Column Shift	Trans Floor Shift	Std. Column Shift	Trans Floor Shift
1-5/8	2-1/4	D	Y	Y	N	Y
Footnotes: 2, 3, 4, 12, 16 & 18						

FULL LENGTH, SMALL BLOCK HEADERS

Will fit standard and auto transmission floor shift only. Fits angle plug heads and features 1-3/4" primary tubes. Requires factory transmission side mounts to be removed for clearance.

1955-57 Coated #12789.....\$589.95/pr.

Tube Size	Collector Size	Port Shape	Auto Column Shift	Trans Floor Shift	Std. Column Shift	Trans Floor Shift
1-3/4	3	REC	N	Y	N	Y
Footnotes: 4, 8, 10 & 12						

FULL LENGTH, BIG BLOCK HEADERS

Will fit automatic transmissions only. Fits standard deck big blocks only (396-502). Factory transmission side mounts will need to be removed for clearance.

1955-57 Coated #12790.....\$519.95/pr.

Tube Size	Collector Size	Port Shape	Auto Column Shift	Trans Floor Shift	Std. Column Shift	Trans Floor Shift
1-7/8	3	SAP	Y	Y	N	N
Footnotes: 2, 5, 6, 7, 11 & 12						

SHORTIE LS1/LS6 HEADERS

Fits 605 box, side mounts and crossmember. Will not clear 3-speed column shift.

1955-57 Coated, Shortie, LS1/LS6 #14120.....\$509.95/pr.

Tube Size	Collector Size	Port Shape	Auto Column Shift	Trans Floor Shift	Std. Column Shift	Trans Floor Shift
1-3/4	3	RD	Y	Y	N	Y
Footnotes: 2, 3, 6, 13, 14 & 15						

RACK & PINION SHORTIE HEADERS

#17375 is 1-7/8" tube size, 3" collector, SAP port shape, auto. transmission floor shift, standard floor shift.

1955-57 Raw, SB V8 #15405.....\$249.95/pr.

1955-57 Coated, SB V8 #15406.....\$445.95/pr.

1955-57 Coated, BB #17375.....\$690.95/pr.

Tube Size	Collector Size	Port Shape	Auto Column Shift	Trans Floor Shift	Std. Column Shift	Trans Floor Shift
1-5/8	3	REC	Y	Y	N	N
Footnotes: 1, 9, 16, 17, 18, 19 & 20						

Footnotes:

- Will not fit Angle Plug Heads.
- Fits 500/605 Steering Boxes.
- Shortie Design.
- Fits most Angle Port Heads.
- Check Motor Position.
- Motor Stock Location Only.
- Standard Deck Big Block Only.
- Floor Shifter Only.
- Will not fit 168 Tooth Flywheel or Kickout Starters.
- Fits motors 3/4" forward, mid-mount must be removed.
- Must Remove Mid Mounts.
- Fits only with V8 Pitman Arm Casting Danchuk #13870
- O² Bung are installed for sensors.
- LS1/LS6 Engines require LS1 oil pan.
- Requires Street & Performance Adapter.
- Mid Length Design.
- Will not work with D-Port Heads.
- Works with motor in stock or no more than 3/4" forward.
- Will not fit manual transmission hit factory cross shaft.
- Designed for Maval/Unisteer Rack-n-Pinion System.

PLEASE CHECK HEADER CLEARANCE BEFORE MOUNTING. DAMAGED OR MODIFIED HEADERS CANNOT BE RETURNED.



#13188

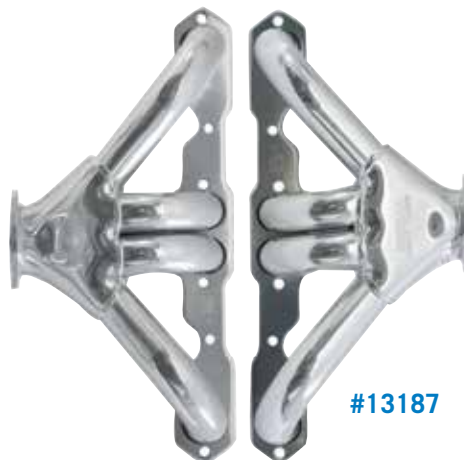

#13187

HEDMAN HEADERS O/S

Hedman has been making headers for 50 years. They use state of the art header design utilizing mandrel bent tubes. The Elite Series are made with heavy duty 14 gauge tubing, 3/8" flanges and have a satin finish Hi-Tech HTC ceramic coating. The D-Port style is specially designed for cylinder heads with D-Shaped exhaust ports and is HTC coated. D-Shaped on Tite Tube only. Tite-Tube headers offer the lowest profile for very tight engine compartments and feature a unique 4 into 1 collector and HTC coating, ideal for lowered cars. **NOTE: SEE OUR WEBSITE FOR PHOTOS OF ALL HEADERS.**

HEDMAN HEADERS - ELITE

Will clear 605/500 box and angle plug heads (Chevy Only). Must use parts #871, #871B or stock motor mounts. Will fit standard and auto transmissions, floor shift only.

1955-57 SB, Coated, Stock Location

..... #13185.....\$568.95/pr.

Tube Size	Collector Size	Port Shape	Auto Column Shift	Trans Floor Shift	Std. Column Shift	Trans Floor Shift
1-5/8	3	RD	N	Y	N	Y

Footnotes: 1, 4 & 5

HEDMAN HEADERS - SHORTY SMALL BLOCK

Will clear 605/500 box and angle plug heads (Chevy Only). Must use parts #871, #871B or stock motor mounts. Will fit standard and auto transmissions, floor shift only.

1955-57 SB, Shorty Style, Painted

..... #13229.....\$254.95/pr.

1955-57 SB, Shorty Style, HTC Coated

..... #13230.....\$576.95/pr.

Tube Size	Collector Size	Port Shape	Auto Column Shift	Trans Floor Shift	Std. Column Shift	Trans Floor Shift
1-5/8	3	RD	N	Y	N	Y

Footnotes: 1, 2, 4 & 5

Footnotes:

1. Fits 500/605 Steering Boxes
2. Shortie Design
3. Square Headers
4. Will fit angle port heads (Chevy Alum only)
5. Motor stock location only
6. Must use with 871, 871B, 12185
7. Must use mini starter

HEDMAN HEADERS - TITE TUBE SMALL BLOCK

Shorty style. Will clear 605/500 box. Small block version will clear column shift transmission. Big block version will not clear 3-speed column shift, and must use mini starter, see part #12892. 502 with aluminum heads; header flange may hit head bolts.

1955-57 SB, Tite Tube, Coated

..... #13187.....\$694.95/pr.

Tube Size	Collector Size	Port Shape	Auto Column Shift	Trans Floor Shift	Std. Column Shift	Trans Floor Shift
1-5/8	2-1/2	RD	Y	Y	Y	Y

Footnotes: 1, 2 & 4

HEDMAN HEADERS - TITE TUBE BIG BLOCK

Shorty style. Will clear 605/500 box. Small block version will clear column shift transmission. Big block version will not clear 3-speed column shift, and must use mini starter, see part #12892. 502 with aluminum heads; header flange may hit head bolts.

1955-57 BB, Tite Tube, Coated

..... #13188.....\$689.95/pr.

Tube Size	Collector Size	Port Shape	Auto Column Shift	Trans Floor Shift	Std. Column Shift	Trans Floor Shift
2	3	SQ	Y	Y	N	Y

Footnotes: 2, 3, 6, 7, 8, 9 & 10

8. Will need to modify the firewall
9. May need to notch flange at head bolts on 502 aluminum heads (Gen 6 Engines)
10. Without smog injection or injection heads.

PLEASE CHECK HEADER CLEARANCE BEFORE MOUNTING. DAMAGED OR MODIFIED HEADERS CANNOT BE RETURNED.

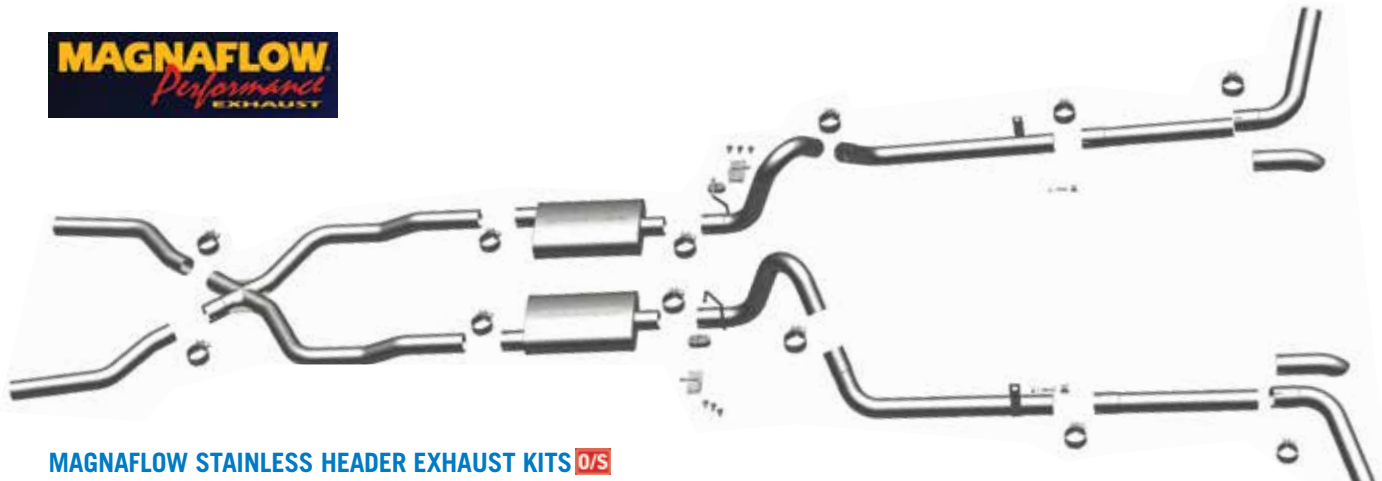

MAGNAFLOW STAINLESS HEADER EXHAUST KITS O/S

Magnaflow exhaust systems are dyno-tested and proven to make power, giving you performance gains in both horsepower and torque. All tubing is mandrel bent and built to last. Each kit comes with 4" x 8" x 14" dual mufflers, Tru-X pipe, either 2.5 or 3" systems with 2.5 or 3" polished turn down tips. Multiple DUAL REAR EXIT OPTIONS. Get great sound and smooth deep tone with this easy to install kit. Lifetime warranty. **Will not fit wagons or convertibles.**

1955-57 2.5", V8	#15915.....	\$712.95/kit
1955-57 3.0", V8, Polished Tips Not Included.....	#15916.....	\$782.95/kit

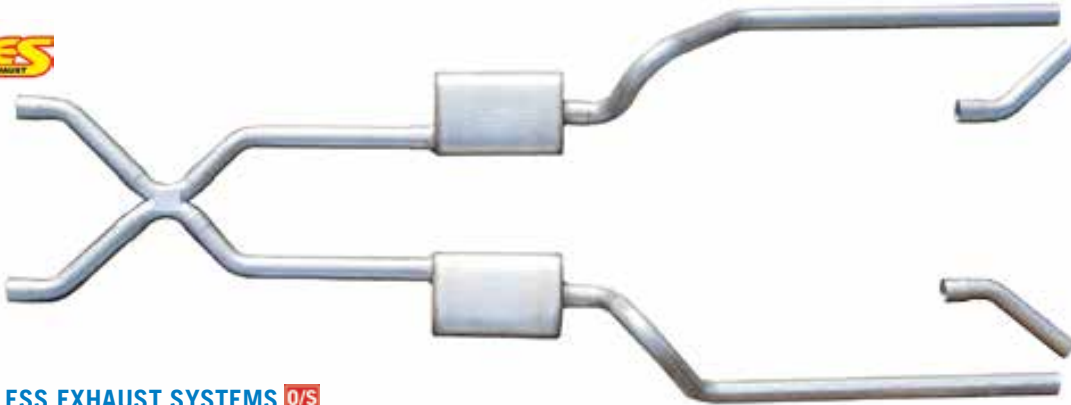

PYPES STAINLESS EXHAUST SYSTEMS O/S

Pypes exhaust systems are designed to deliver enhanced performance, provide extra punch in the passing lane and improve gas mileage. They are fabricated from 16 gauge, mandrel bent, stainless steel pipe which allows them to resist corrosion extending the life of the system and they are a slip fit design for ease of installation. The ultimate in sound and performance. It includes Street Pro or Race Pro mufflers and Pypes patented "X" crossover headpipe. Installation instructions included. **Wagon exhaust kits exit behind the rear wheels below quarter panel. NOTE: Part #19036 is designed for a pocket kit. This kit only works with a centered gas tank and with the spare tire well removed.**

1955-57 Street Pro, 2-1/2", exc. Nomad, Wagon & Convertible	#13518.....	\$524.95/set
1955-57 Street Pro, 2-1/2", exc. Nomad, Wagon & Convertible, For Leaf Spring Pocket Kit	#19036.....	\$519.95/kit
1955-57 Street Pro, 2-1/2", Nomad & Wagon	#16032.....	\$539.95/set
1955-57 Race Pro, 2-1/2", exc. Nomad, Wagon & Convertible.....	#19033.....	\$549.95/kit
1955-57 Race Pro, 3", exc. Nomad, Wagon & Convertible	#19034.....	\$549.95/kit
1955-57 Race Pro, 2-1/2", Nomad & Wagon.....	#19035.....	\$519.95/kit



LS EXHAUST MANIFOLDS

These ceramic coated cast iron block hugger style exhaust manifolds with head pipe adapters help make your LS conversion as easy as possible. Includes gaskets, headpipes and mating flanges.

All Silver (Shown).....	#19410.....	\$419.95/ea.
All Black	#19411.....	\$479.95/ea.



1956 EXHAUST MANIFOLDS

These "Rams Horn" type exhaust manifolds fit all 1956 Chevy passenger cars and Corvettes. They were designed just like the originals, right down to the correct GM casting numbers. Find the exhaust manifold bolts and washers on page 356. They will help you to complete the job.

1956, '56 Vette, 2"	#2237.....	\$539.95/pr.
---------------------------	------------	--------------



RAMS HORN EXHAUST MANIFOLDS

These replacement "Rams Horn" manifolds feature a 2-inch center exit design which allows it to be used on the driver side when the cast-in alternator bracket is not required. This manifold comes with flange studs and gasket, manifold gaskets, nuts and washers.

1955-57 2", Driver	#15553	\$89.95/ea.
1955-57 2", Passenger.....	#15554	\$135.95/ea.

EXHAUST MANIFOLD HEAT RISERS

The exhaust heat riser installs in the right exhaust pipe and is closed when the engine is cold. While closed it forces exhaust gasses up under the carburetor plenum helping with cold engine drivability. A coil and weight on the heat-riser flap allows the valve to flap open when the engine warms up.



1957-65 V8, 2"	#12728.....	\$79.95/ea.
1957-65 V8, 2-1/2"	#12729.....	\$85.95/ea.

1957 EXHAUST HEAT RISER SPACERS

Heat riser spacers are used in place of the heat riser valve when your needs don't require a shorter warm up period and you want maximum exhaust flow.



1957 2"	#12724.....	\$47.95/ea.
1957 2-1/2"	#12725.....	\$49.95/ea.



FLOWMASTER TAILPIPES O/S

Exits under rear bumper. Use with offset/center mufflers. Will not fit wagons.

All 2.5", Aluminized, exc. Wagons	#12973.....	\$189.95/pr.
--	-------------	--------------

ELECTRIC EXHAUST CUTOUT KITS

Nothing gets a gearhead excited like the sound of open headers and with these exhaust cutout kits you can go from muffled to open headers with a flip of a switch. Totally redesigned and made from 304 stainless, these feature a high torque 12 volt DC gear reduction motor with a self adjusting and self cleaning gate for a totally leak proof seal with zero obstructions when open. Kits include the cutouts, Y-pipe, stainless steel band clamps, wiring, gaskets and hardware.



All 2-1/2"	#18733.....	\$434.95/kit
All 3"	#18734.....	\$447.95/kit
All 2-1/2" Cut-Outs Only	#18735.....	\$369.95/pr.
All 3" Cut-Outs Only	#18736.....	\$369.95/pr.

POWER STEERING HEAT SHIELDS

This power steering hose heat shields install around the exhaust pipe and keeps the hose from contacting the exhaust.



1955-57 Short Heat Shield	#18905.....	\$41.95/ea.
1955-57 Long Heat Shield, V8, Single Exhaust	#18906.....	\$47.95/ea.

STAINLESS EXHAUST CUTOUT TURNDOWN

Made to accompany the Doug's electric exhaust cutout kits these 304 stainless steel exhaust turndowns allow you to route your exhaust flow away from the floor boards or in any direction you want. Stainless bands are included for a weld free leak proof attachment.



All 2-1/2"	#18737.....	\$35.95/ea.
All 3"	#18738.....	\$39.95/ea.



EXHAUST HEAT RISER GASKETS

Everyone hates exhaust leaks in their classic. So if your heat riser is the leaky culprit stop the noise with this quality gasket. Mounts between the exhaust flange and the heat riser.

1957-Up 2-1/2"	#16235.....	\$1.95/ea.
1957-65 V8, 2"	#2197.....	\$3.95/ea.



STEEL EXHAUST CLAMPS

1955-57 1-7/8"	#10310...	\$3.50/ea.
1955-57 1-3/4" Crossover	#10311...	\$3.50/ea.
1955-57 2"	#10312...	\$2.95/ea.
1955-57 2-1/2"	#10313...	\$3.50/ea.

WARNING! Products on these pages may contain chemicals known to the State Of California to cause cancer and/or birth defects or reproductive harm. www.p65warnings.ca.gov



#2247

EXHAUST MANIFOLD BOLTS AND WASHERS

One set required per car.

- 1955-56 V8, '55 Vette #2247 \$22.95/set
- 1957-64 V8 #2261 \$24.95/set

STAINLESS STEEL EXHAUST MANIFOLD WASHERS



These long-lasting stainless steel washers should be used in conjunction with our stainless steel exhaust manifold studs and our brass exhaust manifold nuts, part #2208, shown below.

- All #2194 \$9.95/set

BRASS EXHAUST MANIFOLD NUT

If your exhaust manifold nuts are steel, chances are they've fused together with the studs and washers. To prevent this from happening, use our brass exhaust manifold nut. The 1957 6-cylinder uses two nuts, the 1955 and 1956 V8's require four nuts, and the 1957 V8 needs six nuts.



- 1955-57 #2208 \$3.95/ea.



Photo courtesy of GERTMAN2000



FEL PRO EXHAUST MANIFOLD GASKET SET

These exhaust manifold gaskets are a direct replacement for your originals. Manufactured from compressed fiber with a steel core they guarantee a leak free seal and a perfect fit.

- 1955-96 SB #16215 \$9.95/set



EXHAUST MANIFOLD BOLT LOCKS

The regular heat-up and cool-down of the exhaust manifold will work those unprotected bolts loose. This hardware kit will aid in keeping the manifold bolts tight.

- 1955-56 V8, '55-56 Vette #1528 \$15.95/set
- 1957 V8, '57-'63 Vette (Shown) ... #1529 \$15.95/set



#17911

EXHAUST MANIFOLD FLANGE GASKETS

#16236

Everyone hates exhaust leaks in their classic. So if your exhaust flange is the leaky culprit stop the noise with these quality gaskets.

- 1955-56 Heat Riser to Mani., V8.. #17911 \$3.50/ea.
- 1955-57 2" Rams Horn #16236 \$3.76/ea.
- 1955-57 2-1/2" Rams Horn #16237 \$2.95/ea.



STAINLESS EXHAUST BAND CLAMPS

- All 2.5" x 1" #19031 \$9.95/ea.
- All 3" x 1" #19032 \$9.95/ea.



PYPES EXHAUST TIPS

- All 2-1/2", Stainless, 2" x 8" Rectangle #14304..... \$135.95/pr.
- All 3", Stainless, 2" x 8" Rectangle #14305..... \$139.95/pr.
- All 2-1/2", Stainless, 9" Angle Cut #14306..... \$39.95/pr.



POWER PACK EXHAUST EXTENSIONS

This stainless steel jewel is a beautiful way to finish your tailpipe, and the original design for the Power Pack drivetrain.
 1955-56 V8 Dual..... #1291..... \$179.95/pr.



STAINLESS EXHAUST TIPS

- All 3" x 9" #19030..... \$44.95/pr.



FLOWMASTER EXHAUST TIP

All 2.25", Rolled Edge, Double Wall (Shown)
 #12969..... \$74.95/ea.

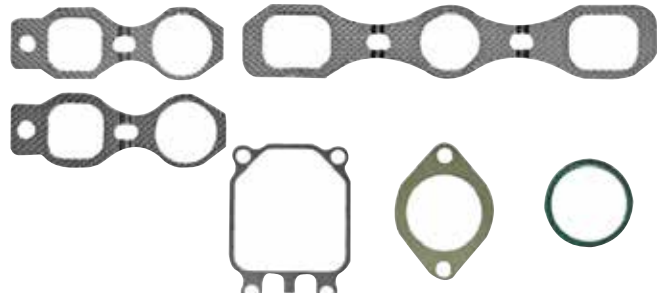

INTAKE/EXHAUST GASKET SET

- 1955-57 6-Cylinder #18134..... \$14.95/set



EXHAUST EXTENSION

This beautiful chrome plated accessory has all the detail and quality of the original with one exception: you won't have to search endlessly to find ours! Exhaust extensions eliminate discoloration of the rear bumper, and this one has an inner heat baffle to protect itself.
 1955-56 V8 2 BC, 6-Cyl. Single ... #379..... \$38.95/ea.



CAM LOCK V8 HEADER BOLTS

- All SB 3/4" #17804..... \$29.95/set
- All BB 3/4" #17805..... \$35.95/set
- All SB 1" #17806..... \$31.95/set



SLIP-FIT STAINLESS EXHAUST TIPS

- All 2-1/2" #13611..... \$99.95/pr.
- All 3" #13612..... \$119.95/pr.



CHEVY ALUMINUM HEADER GASKET KITS

Proform's soft aluminum gaskets conform to the header flanges for a superior seal. Each kit comes with two gaskets.

All SB, Square Port	#16912.....	\$27.95/kit
All BB, Round Port	#16913.....	\$29.95/kit

MUFFLER AND TAILPIPE



ARP STAINLESS HEADER BOLTS

All SB, Hex	#14005.....	\$31.95/set
All SB, 12-pt.....	#14006.....	\$31.95/set
All BB, Hex	#14007.....	\$42.95/set
All BB, 12-pt.....	#14008.....	\$41.95/set
All LS, Hex, 3/8" Flange	#18234.....	\$69.95/kit
All LS, 12-pt., 3/8" Flange	#18235.....	\$75.95/kit



MUFFLER HANGER BRACKETS

These brackets are mounted directly to the car frame, just behind the muffler. In 1955, dual exhaust systems required a special bracket for the driver side, #2347. The other bracket, part #2348, is for the passenger side of all 1955 cars, and either side of 1956-57 cars with single or dual exhaust systems.



1955 w/ Dual Exhaust, Driver	#2347.....	\$8.95/ea.
1955 Passenger, '56-57, Either Side	#2348.....	\$7.95/ea.
1955-57 Driver, Stainless	#18613.....	\$17.95/ea.
1955-57 Passenger, Stainless.....	#18614.....	\$14.95/ea.



TAILPIPE HANGER BRACKETS

These brackets are mounted to the rear of the car's frame and support the tail pipe hangers.

1955 Driver.....	#2350.....	\$9.95/ea.
1955 Passenger	#2351.....	\$9.95/ea.
1955 Driver, Stainless	#18615.....	\$17.95/ea.
1955 Passenger, Stainless.....	#18616.....	\$14.95/ea.
1956-57 Either Side	#2356.....	\$9.95/ea.
1956-59 Either Side	#18617.....	\$14.95/ea.

MALLEABLE ALUMINUM COLLECTOR GASKET KITS

Proform's soft aluminum gaskets conform to the collector flanges for a superior seal. Each kit comes with two gaskets and six nuts and bolts.



All 2.5"	#16909.....	\$11.95/kit
All 3"	#16910.....	\$11.95/kit
All 3.5"	#16911.....	\$11.95/kit

REAR RUBBER MUFFLER HANGER

Why settle for inferior hardware when the original design is still available? The only way to mount a muffler is with a rubber muffler hanger.



1955-57	#860.....	\$12.95/ea.
---------------	-----------	-------------



MUFFLER/TAILPIPE HANGER REBOUND CLIP

This is the rebound clip that is used with muffler and tailpipe hangars. Used primarily on 1955-56 vehicles, it was also used on some early 1957 cars. It is used on 1955 models for the muffler hangar, on 1955-56 for the tailpipe hangar and on early 57's for both.

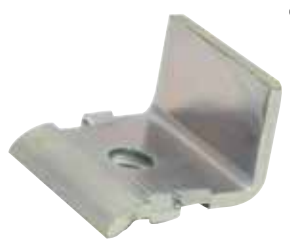

1955-57 #18607..... \$9.95/ea.

EXHAUST CLAMP AND HANGER KITS

Kits include everything from headpipe to tailpipe to install exhaust kits.

1955 6-Cyl.....	#19426.....	\$89.95/kit
1956 6-Cyl.....	#19427.....	\$89.95/kit
1957 6-Cyl.....	#19428.....	\$89.95/kit
1955 V8 Single.....	#19429.....	\$119.95/kit
1956 V8 Single.....	#19430.....	\$119.95/kit
1957 V8 Single.....	#19431.....	\$119.95/kit
1955 V8 Dual.....	#19432.....	\$179.95/kit
1956 V8 Dual.....	#19433.....	\$179.95/kit
1957 V8 Dual.....	#19434.....	\$179.95/kit

#18618



#18619



MUFFLER HANGERS

These assemblies, which support the muffler, are located just behind the muffler and are hung from the muffler hanger brackets. A rubber hanger strap is included with each muffler hanger. Fits 2-inch diameter exhaust.



#2346

1955-56 Either Side, Stainless.....	#18618.....	\$19.95/ea.
1957 Either Side, Stainless.....	#18619.....	\$19.95/ea.
1955-56 Either Side.....	#2344.....	\$26.95/ea.
1957 Either Side (Shown).....	#2346.....	\$24.95/ea.



#18609



#18610

TAILPIPE HANGERS

Our tail pipe hangers are part of the rear support of the tail pipe and are hung from the tail pipe hanger brackets. Tail pipe hangers listed here are sold individually and include a tail pipe clamp. Fits 2-inch diameter exhaust.

1956 Either Side.....	#2352.....	\$35.95/ea.
1957 Driver.....	#2354.....	\$32.95/ea.
1957 Passenger.....	#2355.....	\$32.95/ea.
1955 Either Side, Stainless.....	#18608.....	\$54.95/ea.
1956 Driver, Stainless.....	#18609.....	\$24.95/ea.
1956 Passenger, Stainless.....	#18610.....	\$19.95/ea.
1957 Driver, Stainless.....	#18611.....	\$54.95/ea.
1957 Passenger, Stainless.....	#18612.....	\$54.95/ea.

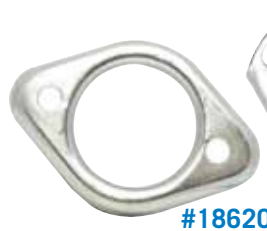

#18620



#18621



#18622

EXHAUST FLANGES

Exhaust flanges install over the exhaust pipe and the exhaust flange bolts go through them into the exhaust manifold to tighten the exhaust pipe to the manifold outlet.

1955-56 V8, 55-64 6-Cyl.	#18620.....	\$7.95/ea.
1957-64 3-Bolt, 2".....	#18621.....	\$3.95/ea.
1959-64 3-Bolt, 2-1/2".....	#18622.....	\$11.95/ea.



EXHAUST MANIFOLD STUDS WITH NUTS

1955-56 1-1/2", V8, Stainless	#18623.....	\$6.95/ea.
1957 3", 6-Cyl/V8, Passenger.....	#18624.....	\$8.95/ea.
1955-57 2 1/2", V8, Driver.....	#18625.....	\$6.95/ea.

WARNING! Products on these pages may contain chemicals known to the State Of California to cause cancer and/or birth defects or reproductive harm. www.p65warnings.ca.gov

Exhaust

INSULATION

The Original Exhaust Insulating Wrap™ was developed over 20 years ago by Thermo-Tec™. Exhaust insulating wrap is an innovative way to create more horsepower and reduce temperatures under the hood. Wrapping headers with exhaust insulating wrap maintains hotter exhaust gases that exit the system faster through decreased density. This produces increased exhaust scavenging, as well as lower intake temperatures. Exhaust insulating wrap withstands continuous heat up to 2000°F; it contains no asbestos. Thermo-Tec's exhaust wrap will not over-insulate a system when properly installed, due to its proprietary coating - Thermo-Conductive-Technology (T-C-T™), specially developed by Thermo-Tec, that conducts heat across the wrap's surface. This unique coating controls heat buildup and dissipation. Exhaust insulating wrap, available in neutral and graphite black, is sold in 50 ft. rolls both one and two inches wide. All exhaust wrap has a low profile of 1/16" thickness.



THERMO-TEC EXHAUST WRAPS

Using wraps voids most header manufacturers warranties. Reduces under hood temperature, increases power and efficiency and can withstand heat up to 2000 degrees. Increases the life of the engine and electronic components.

- All 1" x 50' #13060 \$28.95/ea.
- All 2" x 50' #13061 \$46.95/ea.



THERMO-TEC EXHAUST WRAPS

Thermo-tecs insulating exhaust wrap can withstand temperatures up to 2000 degrees and will not over-insulate when properly installed. Does not contain graphite.

- All Graphite Black, 2" x 50' #15641 \$52.95/ea.
- All Graphite Black, 1" x 50' #15640 \$33.95/ea.



THERMO-TEC SNAP STRAP KIT

Snap Straps are high-quality stainless steel straps with a dependable multi-lock system that are perfect for keeping the thermal wrap on your headers from coming loose. These narrow width straps are pre-cut to length and come with the multi locks pre-attached for ease of use, just insert the end and pull. Danchuk #13073 is a "V-8" kit that contains 8 - 9" straps and 4 - 18" straps.

- All 12 Straps #13073 \$32.95/kit

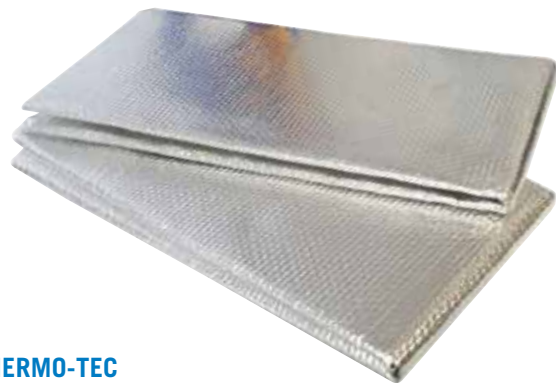

THERMO-TEC HEADER MANIFOLD BLANKET

The header manifold blanket provide excellent heat retention and simply attaches to the upper portion of the header/manifold. The aluminized surface faces out offering protection from abrasions and spills. Blankets measure 20" x 24" each.

- All V8 #15642 \$92.95/pr.