

# 8. Heating & Cooling

## **SECTION AT A GLANCE:**

Heater Cores .....	362
Heater Valves .....	363
Heater Related .....	364
Heater Hoses & Related .....	367
Thermostats .....	369
Fresh Air .....	370
Fan Shrouds.....	372
Fans.....	373
Radiators .....	376
Radiator Related.....	384
Air Conditioning .....	389



**ALUMINUM DELUXE HEATER CORES**

These aluminum deluxe heater cores are an alternative to the factory copper/brass originals. Fits just like the original. Will not fit standard heater systems.

1955-56 .....	#17766.....	\$129.95/ea.
1957.....	#17767.....	\$129.95/ea.

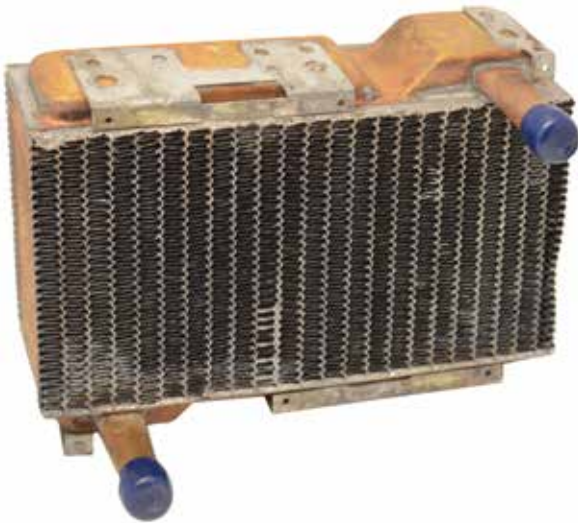

**NEW REPRODUCTION DELUXE HEATER CORES**

These brand new copper/brass heater cores are a direct replacement for your rotted original. Will not fit standard heater systems. Don't forget a new heater valve, on page 363 to make sure you do the job right!

1955-56 .....	#12407.....	\$208.95/ea.
1957.....	#12408.....	\$208.95/ea.



**DELUXE HEATER CONTROL BEZELS**

If you want to convert your car to deluxe heating, this bezel is an important part of the assembly. For restorers who are renewing their dash, a crisp reproduction is a more economical alternative to polishing and replating.

1955-56 .....	#2557.....	\$99.95/ea.
1957.....	#11167.....	\$149.95/set

**DELUXE HEATER ASSEMBLY FASTENERS**

To properly finish a rebuilt heater assembly use these original design fasteners. All the clips, sheet metal screws, and machine screws to do the job right.



1955-56 .....	#1036A.....	\$5.95/set
1957 (Shown) .....	#1036.....	\$5.95/set

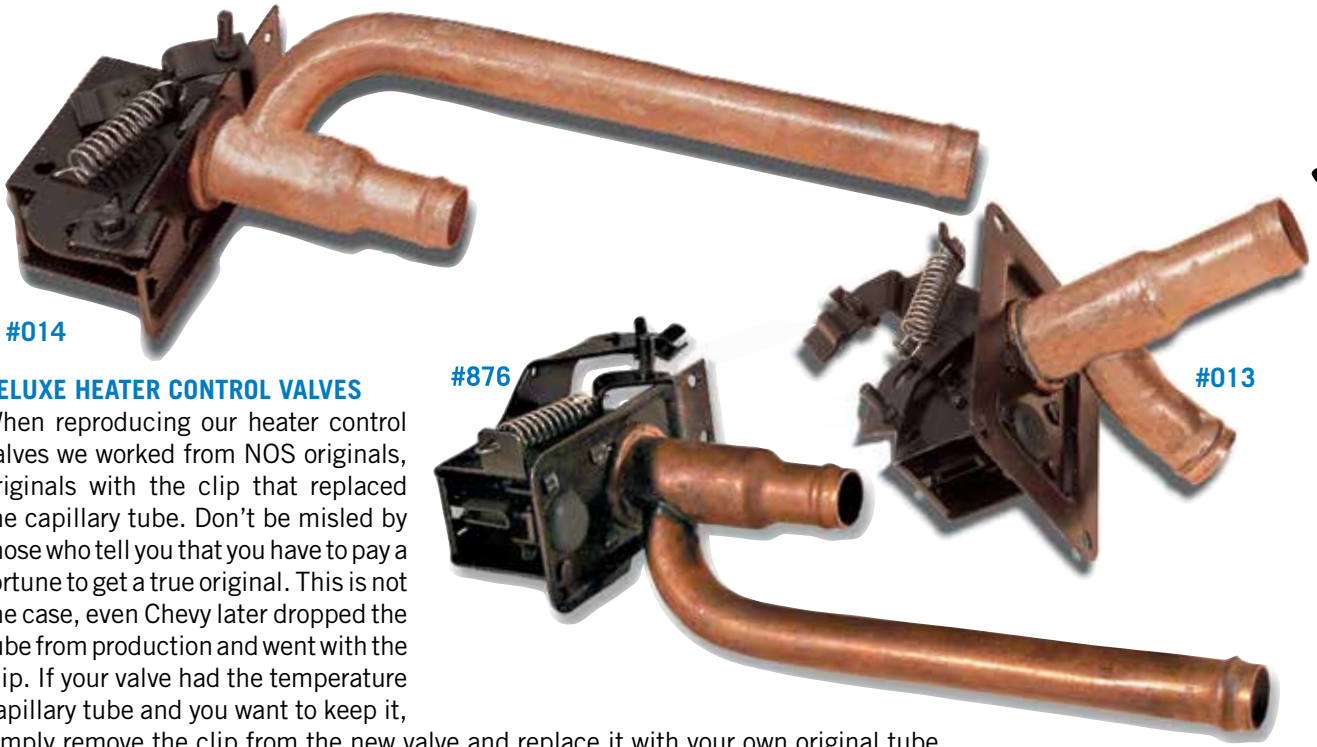

#014

#876

#013

**DELUXE HEATER CONTROL VALVES**

When reproducing our heater control valves we worked from NOS originals, originals with the clip that replaced the capillary tube. Don't be misled by those who tell you that you have to pay a fortune to get a true original. This is not the case, even Chevy later dropped the tube from production and went with the clip. If your valve had the temperature capillary tube and you want to keep it, simply remove the clip from the new valve and replace it with your own original tube.

1955-56 Passenger Cars, 1955-58 Trucks .....	#014.....	\$74.95/ea.
1957 Passenger Cars.....	#013.....	\$74.95/ea.
1958-62 Corvette .....	#876.....	\$74.95/ea.

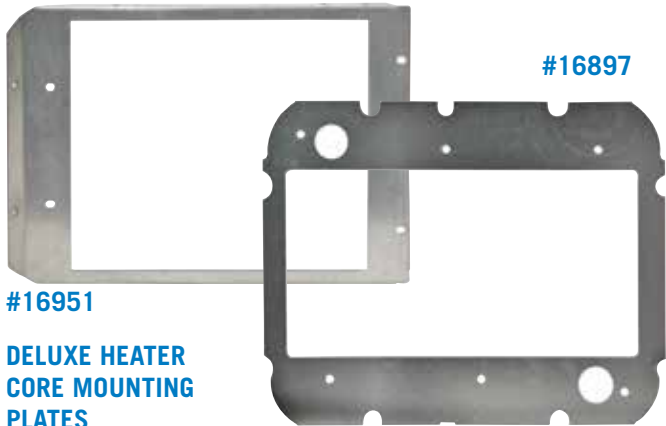

#16897

#16951

**DELUXE HEATER CORE MOUNTING PLATES**

The heater core mounting plate is often corroded or missing. This plate is required when installing the heater core. For deluxe heaters only.

1955-56 .....	#16951 .....	\$16.95/ea.
1957.....	#16897.....	\$16.95/ea.

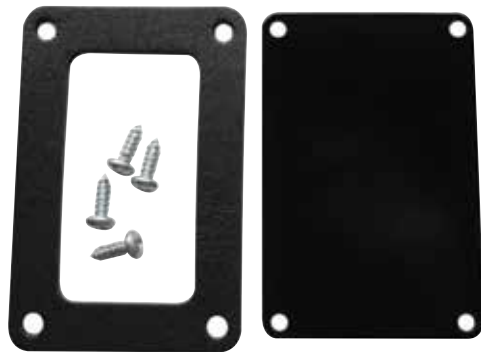

**1957 DELUXE HEATER CONTROL VALVE BLOCK-OFF PLATE**

1957.....	#17410.....	\$6.95/ea.
-----------	-------------	------------

**DELUXE HEATER LEVER PIN AND SPRING REPAIR KIT**

This kit is used on deluxe heaters only and includes the pin that the control levers pivot on as well as the spring and retainers.

1955-56 .....	#15547.....	\$6.25/kit
---------------	-------------	------------



**DELUXE HEATER LENS BACKING PLATES**

This plate installs behind the heater lens and is sometimes missing.

1955-56 .....	#15548.....	\$3.95/ea.
1957.....	#17411.....	\$4.95/ea.





### EZ SLIDER DELUXE HEATER CABLES

EZ Slider cables feature a polyethylene lining which reduces resistance and provides maximum flexibility and instant response.

1955 (Shown) .....	#14953 .....	\$32.95/set
1956 .....	#14955 .....	\$32.95/set
1957 .....	#14957 .....	\$44.95/set

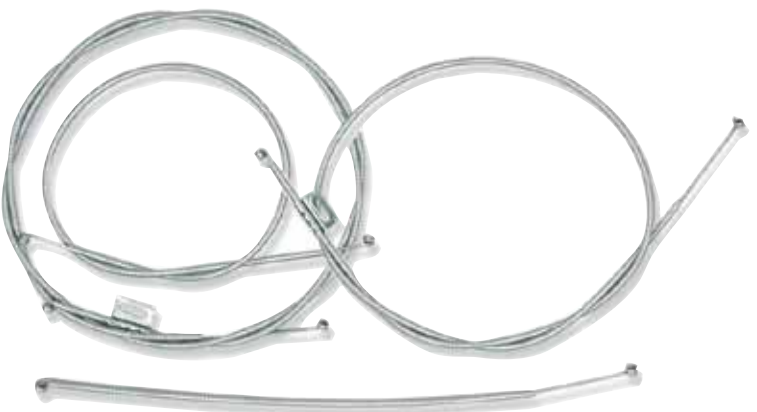

### DELUXE HEATER CABLES WITH STEEL CASING

A little rust, one small kink and your original is shot! These quality steel cables will bring new life to the operation of your heater. 1957 application includes vent cable with casing.

1955 .....	#462 .....	\$29.95/set
1956 .....	#463 .....	\$29.95/set
1957 (Shown) .....	#464 .....	\$65.95/set



### DELUXE HEATER CABLE CLIPS

For deluxe heater controls only.

1955-56 Double .....	#15986 .....	\$6.50/ea.
----------------------	--------------	------------

Fits 55-56 deluxe heater control and 56-57 defroster lever on heater box.

1955-57 Straight Tab, Single .....	#15987 .....	\$5.50/ea.
------------------------------------	--------------	------------

This cable clip set comes with four straight tab single cable and one double cable clip with screws.

1955-56 5-Piece .....	#15988 .....	\$24.95/set
-----------------------	--------------	-------------



### 1957 DELUXE HEATER BOX RETAINERS

1957 .....	#2253 .....	\$23.95/pr.
1957 Chrome .....	#16950 .....	\$34.95/pr.

### 1957 DELUXE HEATER CONTROL CABLE RETAINER CLIPS

Cable retainers are often missing or broken. To order single retainer clip, order part #15594 or part #15595 for the complete 4-piece set needed to handle all cables for deluxe heater control panel.

1957 .....	#15594 .....	\$5.50/ea.
1957 4-Piece .....	#15595 .....	\$19.95/set



### 1957 HEATER HOUSING TO INNER FENDER RETAINER

1957 .....	#2254 .....	\$10.95/ea.
------------	-------------	-------------



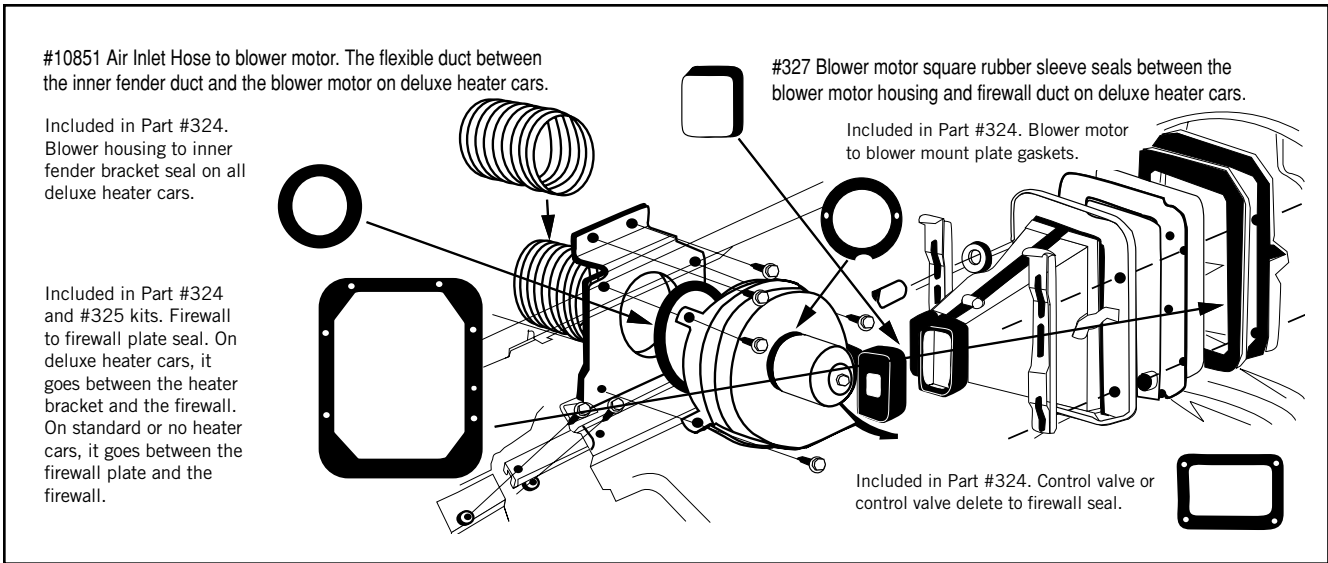

**DELUXE HEATER CONTROL LEVER KNOBS**

These knobs are injection-molded black plastic. 1955 and '56's include mounting hardware; 1957 knobs push on without set screws. These are must-have items when replacing the heater levers, shown below.

1955-56, '55-56 Truck .....	#612.....	\$11.95/set
1957 Best .....	#955.....	\$20.95/set
1957 Good .....	#16800.....	\$14.95/set



**DELUXE HEATER CONTROL LEVERS**

These heater control levers are a perfect reproduction of the originals, except we beefed up the shaft where the knob attaches to help prevent them from breaking.

1955.....	#465.....	\$21.95/pr.
1956.....	#466.....	\$21.95/pr.



**HEATER SEALS**

New gaskets are a necessity when rebuilding your heater assembly. Ours are made from top quality rubber and are designed to last for years. 1955-56 sets include the defroster seal. 1957 applications will require the purchase of #796, 1957 heater defroster seal. **Made in the USA.**

1955-56 Standard Heater .....	#323.....	\$20.95/kit
1955-56 Deluxe Heater.....	#322.....	\$20.95/kit
1957 Standard Heater.....	#325.....	\$17.95/kit
1957 Deluxe Heater.....	#324.....	\$17.95/kit



**POLISHED ALUMINUM DELUXE HEATER CONTROL KNOB SETS**

The finishing touch to your billet dash or a great custom touch all by themselves. Replace your plastic knobs with these billet sets.

1955-56 4-Piece Billet.....	#15585.....	\$102.95/set
1957 5-Piece Billet .....	#15584 .....	\$112.95/set



### HEATER BLOWER MOTORS

These quality replacement motors bolt in place and function just like the originals.

- 1955-63 w/ Air Conditioning, w/o Fan ..... #2077 ..... \$33.95/ea.
- 1955-63 w/o Air Conditioning, w/o Fan (Shown) ..... #2078 ..... \$39.95/ea.



#10213



#10214

### DELUXE HEATER BLOWER SWITCHES

A reproduction of the original, these deluxe heater blower switches will get your heater working again like new. On part #10213 install wires with care to avoid damaging.

- 1955-56 ..... #10213 ..... \$39.95/ea.
- 1957 ..... #10214 ..... \$49.95/ea.



### 1957 DELUXE HEATER BLOWER MOTOR SEAL

This seal, located between the heater blower and the heater transition assembly, is usually in bad shape and should be replaced when rebuilding the assembly. **Made in the USA.**

- 1957 ..... #327 ..... \$5.95/ea.

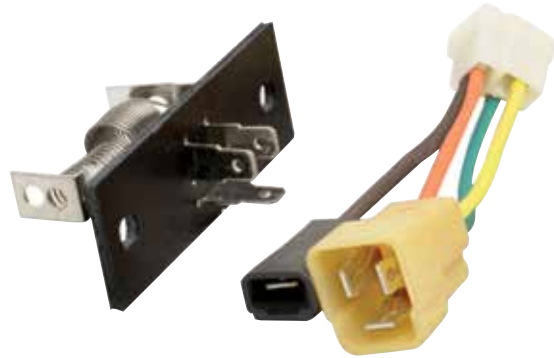

### 1957 DELUXE HEATER BLOWER MOTOR RESISTOR WITH ADAPTER HARNESS (WITHOUT AIR CONDITIONING)

If you are getting only one speed, or nothing at all, from your heater blower motor, this could be the problem.

- 1957 ..... #16216 ..... \$32.95/ea.



### 1957 HEATER BLOWER HOLE COVERS

- 1957 Cad Plated ..... #11234 ..... \$29.95/ea.
- 1957 Chrome Plated ..... #11235 ..... \$49.95/ea.



### 1957 HEATER MOTOR MOUNTING SCREWS

- 1957 ..... #2888 ..... \$8.95/set



Performance Stainless Steel products are **Made in the USA** of ultra-high quality 304 stainless and keep their beauty way beyond chrome or aluminum. They have an unmistakable ultra smooth finish that is highly resistant to rust, pitting and discoloration.

**STAINLESS HEATER HOSE FITTINGS**

1955-57 Hex,	5/8" ID x 1-3/4",	1/2" NPT	.....	#14744	.....	\$12.95/ea.
1955-57 Hex,	5/8" ID x 2-7/8",	1/2" NPT	.....	#14745	.....	\$18.95/ea.
1955-57 Hex,	3/4" ID x 1-3/4",	1/2" NPT	.....	#14746	.....	\$14.95/ea.
1955-57 Hex,	3/4" ID x 2-7/8",	1/2" NPT	.....	#14747	.....	\$19.95/ea.
1955-57 Hex,	5/8" ID x 1-3/4",	1/2" NPT	.....	#14748	.....	\$23.95/ea.
1955-57 12-Pt.	5/8" ID, 1-3/4",	1/2" NPT	.....	#14750	.....	\$15.95/ea.
1955-57 12-Pt.	5/8" ID x 2-7/8",	1/2" NPT	.....	#14751	.....	\$19.95/ea.
1955-57 12-Pt.	3/4" ID x 1-3/4",	1/2" NPT	.....	#14752	.....	\$15.95/ea.
1955-57 12-Pt.	3/4" ID x 2-7/8",	1/2" NPT	.....	#14753	.....	\$17.95/ea.
1955-57 45-Deg.	5/8" ID x 1-3/4",	1/2" NPT	.....	#14756	.....	\$34.95/ea.
1955-57 90-Deg.	5/8" ID x 2-1/8",	1/2" NPT	.....	#14757	.....	\$34.95/ea.
1955-57 90-Deg.	5/8" ID x 1-3/4",	1/2" NPT	.....	#14758	.....	\$34.95/ea.
1955-57 90-Deg.	3/4" ID x 1-3/4",	1/2" NPT	.....	#14759	.....	\$34.95/ea.
1955-57 90-Deg.	3/4" ID x 2-1/8",	1/2" NPT	.....	#14760	.....	\$34.95/ea.
1955-57 2-Piece	5/8" ID x 1-3/4",	1/2" NPT	.....	#15301	.....	\$38.95/pr.
1955-57 2-Piece	5/8" ID x 2-1/8",	1/2" NPT	.....	#15302	.....	\$38.95/pr.



**STAINLESS HEATER HOSE FITTING SETS**

1955-57 Hex, Contains (2) 5/8" ID x 1-3/4" & (2) 1/2" Plugs (Shown)	.....	#14773	.....	\$41.95/set
1955-57 Hex, Contains (1) 5/8" ID x 1-3/4", (1) 5/8" x 2-7/8" & (2) 1/2" Plugs	.....	#14774	.....	\$43.95/set
1955-57 12-Pt. Contains (2) 5/8" ID x 1-3/4" & (2) 1/2" Plugs (Shown)	.....	#14775	.....	\$41.95/set
1955-57 12-Pt. Contains (1) 5/8" x 1-3/4", (1) 5/8" x 2-7/8" & (2) 1/2" Plugs	.....	#14776	.....	\$49.95/set
1955-57 Hex, Contains (1) 5/8" ID, x 2-7/8" & (1) 5/8" ID x 1-3/4", 1/2" NPT	.....	#14749	.....	\$27.95/set
1955-57 12-Pt. Contains (2) 5/8" ID x 1-3/4", 1/2" NPT	.....	#14754	.....	\$28.95/set
1955-57 12-Pt. Contains (1) 5/8" ID x 1-3/4" & (1) 5/8" ID x 2-7/8", 1/2" NPT	.....	#14755	.....	\$31.95/set



**STAINLESS SOCKET HEAD PLUGS**

1955-57 1/2" NPT	.....	#14769	.....	\$6.95/ea.
1955-57 3/8" NPT	.....	#14770	.....	\$5.95/ea.
1955-57 1/4" NPT	.....	#14771	.....	\$4.95/ea.
1955-57 1/8" NPT	.....	#14772	.....	\$2.50/ea.
1955-57 3/4" NPT	.....	#15305	.....	\$15.95/ea.

**STAINLESS 12-POINT PLUG**

1955-57 1/2" NPT	.....	#14768	.....	\$10.95/ea.
------------------	-------	--------	-------	-------------

**STAINLESS HEX PLUG**

1955-57 1/2" NPT	.....	#14767	.....	\$9.95/ea.
------------------	-------	--------	-------	------------





**ADJUSTABLE FAN THERMOSTAT**

For use with electric fans. Probe mounts in stock drain plug hole on the radiator. Adjustable temp makes sure the fan runs when needed.

All..... #085..... \$43.95/ea.

**ADJUSTABLE THERMOSTAT HARNESS**

For use with part #085, adjustable fan thermostat.

All..... #085A..... \$49.95/ea.



**FLEXI-KOOL HEATER HOSE KIT**

Flexi-Cool hose kit is made of ribbed stainless steel which won't freeze or crack. Flexi-Cool hoses ribbed design improves cooling which helps prevent overheating and possible engine damage. Hoses can be formed to any angle or length while reducing installation time and maintenance costs. Kits include two 44" hoses. Makes two hoses. Dress caps and Flexi-Kool Radiator hoses are shown on page 387.

All 44", Chrome w/ Chrome Caps .. #12414..... \$64.95/kit



**ORIGINAL STYLE HEATER HOSE KITS WITH RIBS**

These are original style hoses with the ribs and GM markings. Kit includes original style clamps. **Made in the USA.**

- 1955-56 V8 ..... #11237..... \$39.95/kit
- 1955-56 6-Cyl..... #11238..... \$39.95/kit
- 1957 V8..... #11239..... \$39.95/kit
- 1957 V8 w/ A/C ..... #11240..... \$39.95/kit
- 1957 6-Cyl..... #11241..... \$39.95/kit

**HEATER HOSE BRACKET**

This beautiful chrome bracket suspends the heater hoses above the exhaust manifolds to protect the hoses from heat damage, and gives the engine compartment an organized appearance too. Brackets can be used individually or in pairs, depending upon the application. Some engines with air conditioning systems use only one bracket.

All..... #1963..... \$6.95/ea.



**1957 HEATER HOSE BRACKET**

This bracket installs under the battery box and keeps the heater hoses from the water pump and from the thermostat housing neatly routed in the engine compartment.

1957..... #1211..... \$6.75/ea.



**INNER FENDER HEATER HOSE CLAMPS**

These solid, heavy stainless steel clamps are polished to a high luster and include stainless steel Allen head screws.

- 1955-57 Plain..... #2511..... \$19.95/ea.
- 1955-57 Slotted ..... #2512..... \$19.95/ea.

**INTAKE MANIFOLD FITTINGS**

- 1955-56 5/8" ..... #10066..... \$17.95/ea.
- 1957 3/4" ..... #12225..... \$16.95/ea.



**INTAKE MANIFOLD HEATER HOSE FITTING**

This beautiful corrosion resistant chrome fitting adds a distinctive detail to any engine. For use on small and big block intake manifolds.

All V8, 5/8" Hose, 1/2" NPT..... #1962..... \$7.50/ea.







**STAINLESS THERMOSTAT SWIVEL HOUSINGS**

- All 15°, Satin (Shown) ..... #14777..... \$154.95/ea.
- All 15°, Polished (Shown) ..... #14778..... \$179.95/ea.
- All 45°, Satin..... #14779..... \$154.95/ea.
- All 45°, Polished ..... #14780..... \$179.95/ea.
- All Straight, Satin ..... #15299..... \$114.95/ea.
- All Straight, Polished ..... #15300..... \$139.95/ea.



**BILLET SPECIALTIES SWIVEL THERMOSTAT HOUSINGS**

- All 90°, Polished ..... #17091..... \$92.95/ea.
- All 15°, Polished ..... #17092..... \$92.95/ea.
- All 45°, Polished ..... #17093..... \$92.95/ea.
- All 90°, Black..... #19374..... \$84.95/ea.
- All 15°, Black..... #19375..... \$84.95/ea.
- All 45°, Black..... #19376..... \$84.95/ea.



**POLISHED, SWIVEL ALUMINUM THERMOSTAT HOUSINGS**

- All 15° Swivel ..... #12505..... \$14.95/ea.
- All 45° Swivel ..... #12124..... \$14.95/ea.
- All 90° Swivel ..... #12125..... \$15.95/ea.

**WATER OUTLET STUD KIT**

These are the two studs for the thermostat housing on V8 engines with the factory Dual 4-bbl carbs or Fuel Injection.



- 1956-61 F. I. & 2 X 4BBL ..... #18934..... \$7.95/kit

**STAINLESS WATER NECK BOLT KITS WITH BOWTIE**

- All 45°, SB ..... #14289.....\$5.95/kit
- All 90°, SB ..... #14290.....\$4.95/kit

- ARP STAINLESS THERMOSTAT HOUSING BOLTS**
- All Hex #14003. \$12.95/set
  - All 12-pt. #14004... \$9.95/set



**TEMPERATURE SENDING UNITS**

Original design in fit and function.

- 1956..... #093..... \$31.95/ea.
- 1957..... #094..... \$29.95/ea.



**THERMOSTATS**

- All..... #081..... \$14.95/ea.
- All 160° ..... #082..... \$8.95/ea.
- All 180° ..... #083..... \$9.95/ea.
- All Gasket..... #084..... \$3.50/ea.

**TEMPERATURE SENDING UNIT WIRE INSULATOR**

The wire insulator covering is usually charred or missing. Replace this key detail item and save yourself from fried wiring.



- All..... #12121..... \$4.50/ea.

**THERMOSTAT HOUSING O-RING**

Replacement O-ring for all stainless thermostat housings.



- All..... #15306..... \$3.50/ea.



**LOWER THERMOSTAT HOUSING GASKET**

- All 235 6-Cyl..... #17886..... \$2.95/ea.

1957 Heater/Duct Seal Location

#326 Air Inlet Sleeve - Fits joint between forward and rear air duct both sides.

#548 Inner Fender Air Duct Seal - Fits the hole in the inner fender that forward air duct passes through to prevent squeaking. Installs originally with six staples each side.

Included in #324 Heater Seal Kits. Rear air duct to firewall seals, glued to the firewall on both sides.

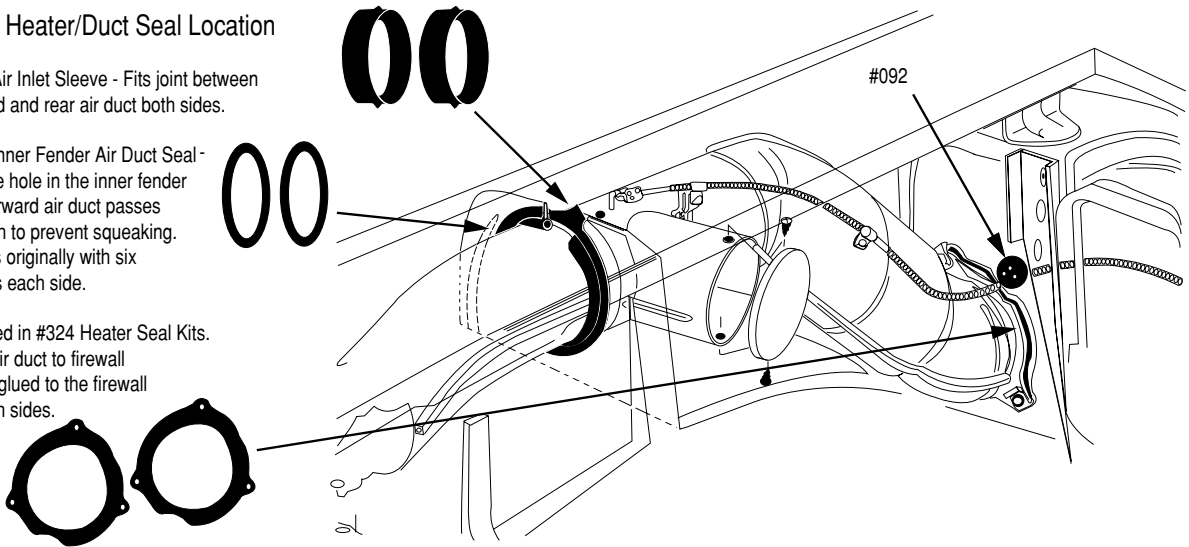

#10436

#15637



FRESH AIR VENT CONTROL CABLES

These are used to open the fresh air vents on cars that were equipped with the standard recirculating heater and include the knob. Two required per car.

1955 w/ Smooth Knob.....	#10435.....	\$66.95/pr.
1956 w/ Ribbed Knob.....	#10436.....	\$66.95/pr.
1957.....	#15637.....	\$35.95/ea.



1957 FRESH AIR VENT COVERS

These are the vent grills that mount under the dash on the firewall. Sold in pairs.



1957.....	#17778.....	\$59.95/pr.
-----------	-------------	-------------

FRESH AIR VENT ASSEMBLY WITH CABLE

These fresh air vent assemblies come as a pair complete with cables. They will work for both 1955 and 56 but the knobs are only correct for 1956. The 1956 cable used a ribbed knob, the 1955 used a smooth knob. (Use Danchuk #14035 vent cables for a correct 1955 installation.)

1955-56 .....	#16036.....	\$124.95/set
---------------	-------------	--------------



1957 FRESH AIR DUCT CABLE RETAINERS

Use these spring steel clips to correctly connect the fresh air cables to your vent assembly.

1957.....	#1204.....	\$3.95/set
-----------	------------	------------



**1957 FORWARD IN FENDER FRESH AIR DUCT**

This is a reproduction of the original fresh air duct that mounts inside the front fenders of 1957's. Fits driver or passenger sides. Two required per car.

1957..... #16875..... \$189.95/ea.



**1957 AIR DUCT DRAIN TUBE**

This tube bolts into the underside of the air ducts and runs forward through the drain tube grommets mounted in the front splash pan. They drain water out of the fresh air ducts.

1957..... #12605..... \$18.95/ea.

**1957 AIR INLET HOSE**

Fits between heater blower and outside air duct.

1957 Original, 4-1/2"..... #10851..... \$17.95/ea.



**1957 AIR INLET DRAIN TUBE GROMMETS**

These mount in the front splash pan on either side and the air inlet drain tubes go through them. These keep the air inlet drain tubes from rattling.

1957..... #334..... \$4.95/pr.



**VENT CABLE TO DASH SCREW AND WASHER KIT**

Original clutch head design.

1955-56 ..... #2895..... \$3.95/kit

**CLUTCH HEAD SCREWDRIVERS**

This 4-piece set should cover all your needs when restoring your classic Chevy.

All 4-Piece Set ..... #16367..... \$21.95/set



**KICK PANEL VENT DOOR SEALS**

1955-56 ..... #10455..... \$12.95/set

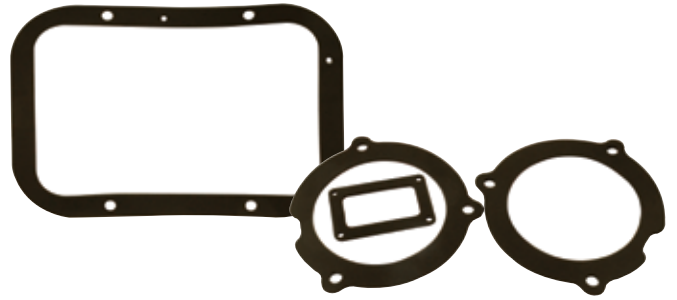

**1957 FRESH AIR VENT SEAL KIT**

1957 Factory Dash w/ Vintage Air ..... #17659..... \$7.95/kit



**1957 AIR DUCT-TO-INNER FENDER SEALS**

1957..... #548..... \$9.95/pr.



**1957 HEATER DEFROSTER SEAL**

This seal is located between the heater distributor assembly and the dashboard vent assembly. Without it the defrost function on the heater will not operate.

1957..... #796..... \$10.95/ea.



**1957 FRESH AIR INLET SLEEVES**

These sleeves seal the connection between the front duct assembly and the rear duct and valve assembly. **Made in the USA.**

1957..... #326..... \$10.95/pr.



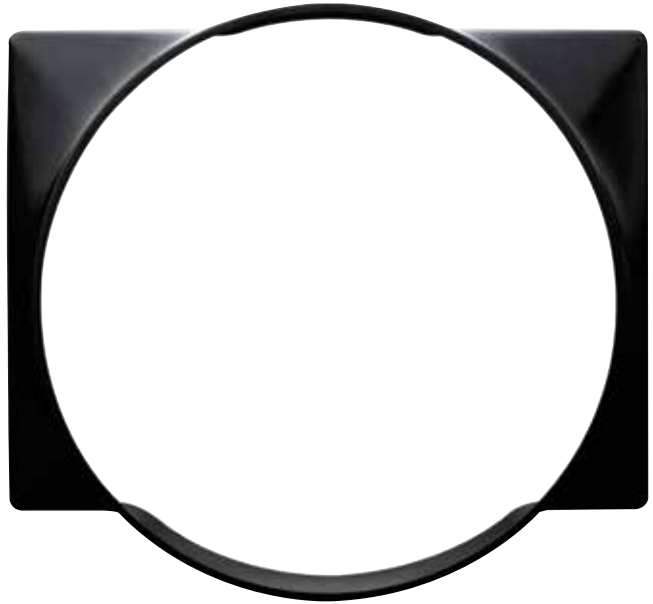

**RADIATOR IN V8 POSITION**

Mounts behind the core support between the core support and the engine inside the engine compartment.

**RADIATOR IN 6-CYL. POSITION**

Mounts in front of the core support between the core support and the grille.

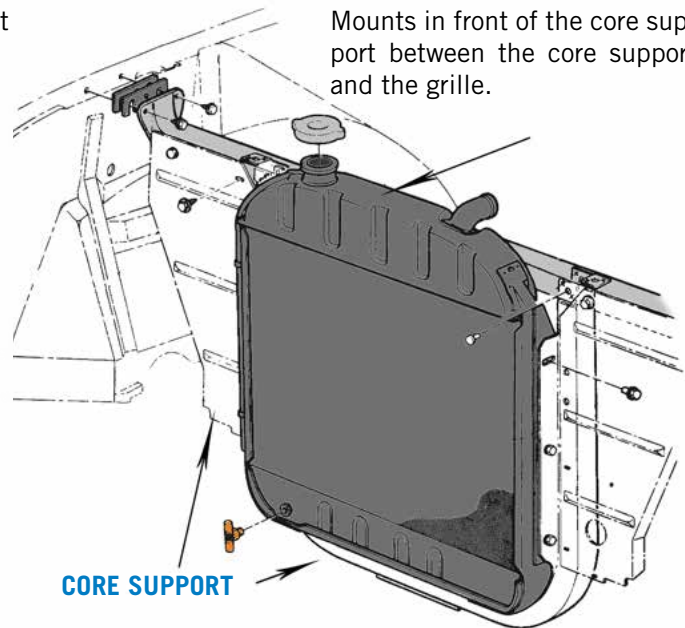
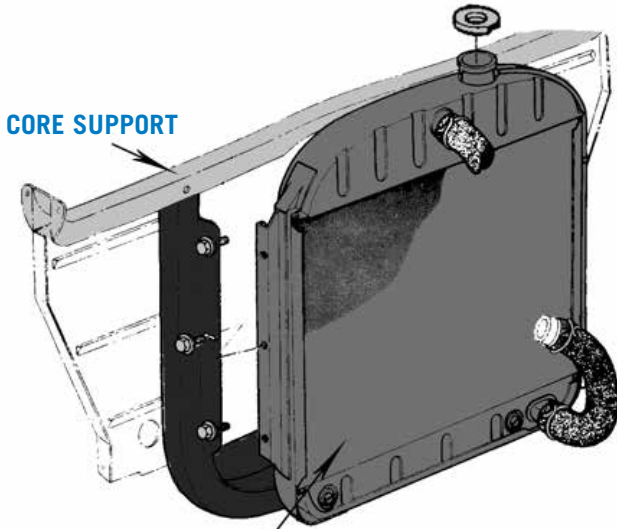

**RADIATOR IN V8 POSITION**

**CHROME STEEL OR BLACK POWDER COATED STEEL FAN SHROUDS**

The best of the best! We pulled out all the stops and made these the way Chevy would have. These beautiful shrouds are made from top quality thick steel, powder coated black or chrome finished and are custom fit for your application. With an 18¾-inches opening you'll have no trouble with fan clearance. **Made in the USA.** US Patent D675,724S.

1955-57 V8 in 6-Cyl. Core Support, Black Shroud..... #16625..... \$129.95/ea.  
 1955-57 V8 in 6-Cyl. Core Support, Chrome Shroud, Black Brackets..... #16625C..... \$249.95/ea.  
 1955-57 Chrome Brackets for #16625C ..... #16625B..... \$69.95/pr.

1955-57 V8 in Stock Position, Black Shroud ..... #16626A..... \$129.95/ea.  
 1955-57 V8 in Stock Position, Chrome Shroud, Black Brackets ..... #16626C..... \$249.95/ea.  
 1955-57 Chrome Brackets for #16626C ..... #16626B..... \$69.95/pr.

1955-57 V8 in 6-Cyl. Position, when using #11236 6-Cyl. Position Conversion Brackets, Black Shroud  
 ..... #16627A..... \$139.95/ea.  
 1955-57 V8 in 6-Cyl. Position, when using #11236 6-Cyl. Position Conversion Brackets, Chrome Shroud,  
 Black Brackets ..... #16627C..... \$259.95/ea.





**Flex-a-lite®**  
**BLACK MAGIC S-BLADE FAN**

Flex-a-lite Black Magic Fans use a lightweight one-piece nylon shroud with full-contact rubber seal mounts as a puller behind radiator. Flex-a-lite Black Magic fans have a rigid bracket system which means no through-core mounting. Great cooling for higher horsepower applications. Includes adjustable thermostat with air conditioning relay, reversible. Measures 16-inches x 18-inches x 4<sup>1</sup>/<sub>4</sub>-inches. **All 3000CFM ..... #18026..... \$319.95/ea.**



**Flex-a-lite®**  
**BLACK MAGIC XTREME ELECTRIC FAN KIT**

The Flex-A-Lite Black Magic Xtreme fan out performs typical cage fans by 45%-50%, and provides consistent cooling regardless of engine speed. Get more power and better mileage by replacing your stock fan. Includes adjustable thermostat, air conditioning relay and manual switch. Available in puller version only. Recommended for 6-cylinder position radiators. Measures 21<sup>1</sup>/<sub>2</sub>-inches x 17<sup>1</sup>/<sub>2</sub>-inches x 4<sup>3</sup>/<sub>16</sub>-inches. Please check and verify clearance before placing order.

**All w/ Relay & Thermostat, 3300 CFM**  
..... #13452..... \$341.95/kit



**FAN MOUNTING BRACKETS**

These brackets give you the extra mounting surface sometimes needed when your radiator is in the 6-cylinder position and you are installing a universal electric fan with a built in shroud like #13452 or #18026 shown at left.

**Made in the USA.**  
1955-57 ..... #11236A..... \$74.95/pr.



Photo courtesy of GERTMAN2000



**ELECTRIC, VARIABLE SPEED FAN CONTROL**

Sets fan speed from 60%-100% depending on thermostat setting. Reduces charging spikes and current load. Runs your cooling fans 30 seconds after your car is turned off to reduce heat soak.

All..... #13459..... \$179.95/ea.



**Flex-a-lite®**

**17-INCH FLEX FAN**

Please check and verify clearance before placing order.  
1955-57 ..... #12164..... \$79.95/ea.



**Flex-a-lite®**

**ELECTRIC FAN SWITCH**

Use this switch as a manual override, regardless of thermostat setting, to turn on or off your cooling fan.  
All Illuminated ..... #13460..... \$24.95/ea.



**Flex-a-lite®**

**AIR CONDITIONING RELAY KIT FOR ELECTRIC FANS**

This relay automatically engages the fan when the air conditioning is turned on.  
All..... #13458..... \$23.95/ea.



**PAINLESS FAN-THOM II ELECTRIC FAN CONTROL KITS**

Fan-Thom fan controls offer you clean, simple and safe fan controller for your electric fans. The supplied thermostat threads into the engine or cooling system for a professional installation.

All 200° ..... #14615..... \$58.95/kit

Note: Turns fan on at 200° & off at 185°.

All 185° ..... #14616..... \$53.95/kit

Note: Turns fan on at 185° & off at 170°.

**DAKOTA DIGITAL PROGRAMMABLE FAN CONTROLLER WITH LED READ-OUT**



This fan controller is programmable and will work with either single or dual fan applications. Set what temp the fan(s) turn on/off as well as having the fans stay on for up to five minutes after the engine is shut down. Digital temp readout makes set up a breeze and it will work with your existing temp gauge and sending unit. Intended to be mounted in cabin. Do not mount in engine compartment.

All ..... #15123..... \$139.95/ea.

**ELECTRIC FAN RELAY KIT**

This fan relay kit can be used either manually or in conjunction with a temperature sending switch. Designed for use with a fused power source. Full instructions for both the switched and manual operation are included.

All..... #12344..... \$25.95/kit



**Flex-a-lite® FAN SPACERS**

1955-57 1/2" ..... #12165..... \$18.95/ea.

1955-57 1" ..... #12166..... \$18.95/ea.

1955-57 2" ..... #12167..... \$21.95/ea.



**VINTAGE AIR DUAL FAN PACKAGES**

Vintage Air designed these specifically to help cool Tri-Five's with cooling problems, and they got it right! These dual electric fan packages are just the thing for those hot summer days cruising at 2 MPH as you don't need any forced airflow, the fans do all the work! The #17011 features two 11-inch 5-blade fans which pull a whopping 2750 CFM of air. Motor thickness is 4.250 and the fan thickness is 2.60 which means it will fit almost anywhere.

- 1955-57 6-Cyl. Position w/ Controls** ..... #17010..... **\$422.95/ea.**
- 1955-57 6-Cyl. Position w/o Controls** ..... #17011..... **\$299.95/ea.**

**Flex-a-lite®**

**S-BLADE ELECTRIC FANS**

These S-Blade fans can be used as a primary or auxillary fan. The 16" Syclone pulls 2500CFM which makes it strong enough to replace your belt driven fan, freeing up horsepower and increasing mileage. Both fans are reversible (push/pull). Please check and verify clearance before placing order.



- All 14", w/o Relay & Thermostat, 1530 CFM** ..... #13457..... **\$119.95/ea.**
- All 16", Syclone, 2500 CFM w/o Relay & Thermostat** ..... #12168..... **\$169.95/ea.**

**ELECTRIC FAN TEMPERATURE SWITCH**

This fan switch is just the thing for controlling those high dollar electric fans you installed. Or maybe you just need a replacement for a unit gone south. This switch installs in the cylinder head or the intake manifold and triggers an electric relay. Turns on at 195° and off at 180° and is 3/8" NPT electric fan switch. **Made in the USA.**



- All 3", ON 195/OFF 180**..... #19005..... **\$26.95/ea.**

**DERALE PWM FAN CONTROLLER**

Derale Performance is changing the rules of engine temperature control with the smart technology of their patented PWM Fan Controller. The controller monitors your engine temperature via the cool side of the radiator, therefore providing a more accurate reading for your cooling system. Using Soft Start Technology, fans ramp up slowly which eliminates harmful AMP spikes. The unit will continuously monitor your engine's temperature and operate the fans at the optimum fan rate as needed between 1 to 100%. The net result; the electric fans often only run between 40-60% to keep your engine cool. Additional benefits include, reduced fan speeds which means reduced fan noise, which tends to compete with that sweet sound of your engine!



- All Variable Speed** ..... #18483..... **\$219.95/ea.**





**COLD-CASE RADIATORS O/S**

COLD-CASE radiators are original appearing and have the correct stampings. They are 100% TIG welded aluminum and feature polished OE style upper and lower tanks and dual 1-1/4" tubes in a core that has 16 fins per inch for superior cooling. The corrugated fins give more surface area and more thermal transfer. Fully pressure tested, these radiators will work for both manual and automatic transmission applications. Danchuk # 18914 is a 1955-1957 direct fit radiator that mounts in the V8 position, # 18915 is a 1955-1956 direct fit radiator that mounts in the 6-cylinder position and # 18916 is a 1957 direct fit radiator that mounts in the 6-cylinder position.

- 1955-1957 V8 ..... #18914..... \$399.95/ea.
- 1955-1956 6-Cylinder ..... #18915..... \$399.95/ea.
- 1957 6-Cylinder ..... #18916..... \$399.95/ea.

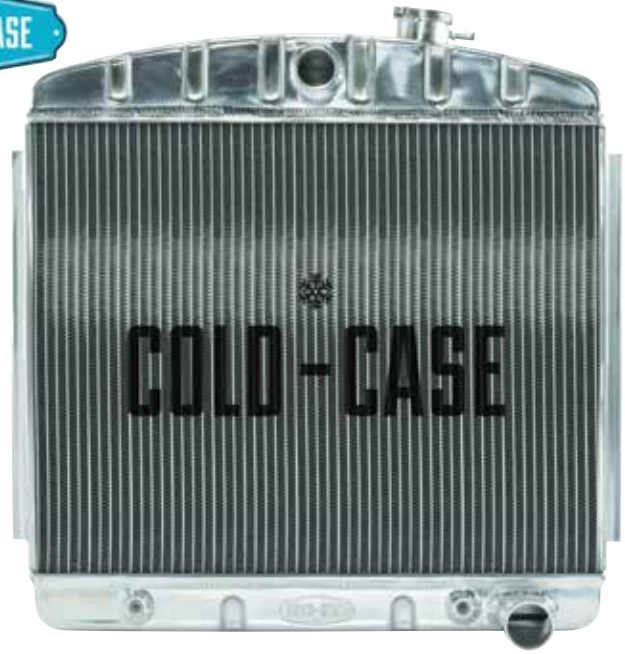

**COLD-CASE RADIATORS WITH FAN AND SHROUD O/S**

COLD-CASE radiators are original looking and have the correct stampings. They are 100% TIG welded aluminum and feature polished OE style tanks and dual 1-1/4" tubes in a core that has 16 fins per inch for superior cooling. The corrugated fins give more surface area and more thermal transfer. Fully pressure tested, these radiators will work for both manual and automatic transmission applications. These kits includes an aluminum fan shroud and a 16" electric fan rated at 2500 CFM. The parts #18917 and #18918 are direct fit radiators that mount in the 6-cylinder position. The #18919 is a V8 radiator with a fan shroud kit that mounts in the 6-cylinder position using part #11236 adapter brackets. Although the #18919 radiator is a direct fit unit, there is not enough room to mount this on the V8 side of the core support with the shroud and fan, so it must be mounted in the 6-cylinder position with required part #11236 brackets. All 3 part numbers require part #18920 or similar electric fan wiring kit.

- 1955-56 w/ Fan and Shroud, 6-Cylinder Mounting Position..... #18917..... \$549.95/ea.
- 1957 w/ Fan and Shroud, 6-Cylinder Mounting Position ..... #18918..... \$549.95/ea.
- 1955-57 w/ Fan and Shroud, V8 Position ..... #18919..... \$549.95/ea.





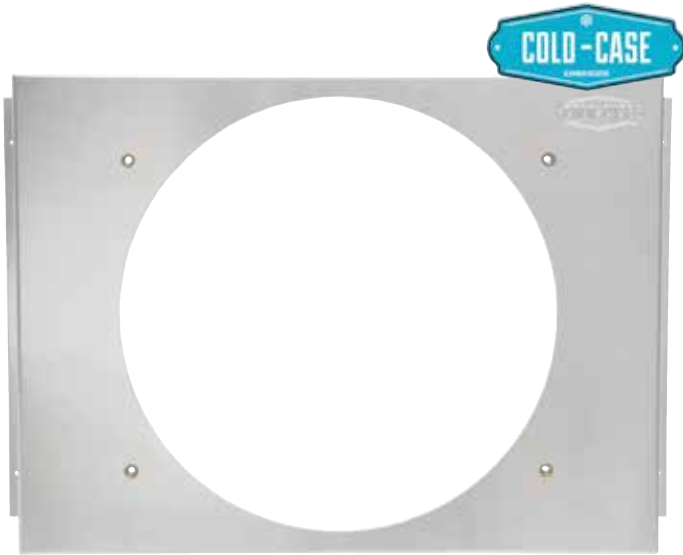

**COLD CASE FAN SHROUDS**

For the customer who has already installed a Cold-Case radiator and now wants to add one of their shrouds and fan kits, we now carry both the shroud and fan separately. For part # 19879, installation will require moving the radiator to the 6-cylinder position with part #11236 conversion brackets. There is not enough room between the water pump and the radiator for installation of this shroud and an electric fan. Use part #18978 electric fan. **Note:** If your radiator is mounted on the engine side of the core support, you have a V8 core support. If it is mounted on the grille side of the core support, then it's a 6-cylinder support, please check before ordering. If you are in doubt as to what you need please call our Customer Service Department at 800-854-6911 for assistance.

**1955-57 V8 Pos. Radiators** ..... #18976 ..... \$79.95/ea.  
**1955-57 6-Cyl. Pos. Radiators** ..... #18977 ..... \$79.95/ea.

**COLD CASE 16" ELECTRIC FAN**

**1955-57 2500 CFM** ..... #18978 ..... \$79.95/ea.



**COLD-CASE ELECTRIC FAN WIRING KIT**

Designed to easily install the Cold-Case radiators with fan and shroud. Includes wiring, thermostat and relay. Turns fans on at 190 degrees.

**All**..... #18920 ..... \$89.95/ea.

**COLD-CASE RADIATOR CAP**

This billet Cold-Case radiator cap is just the thing to cap off your Cold-Case radiator installation. Push on style fits Cold-Case radiators ONLY. Not suitable for use in vehicles using a stock heater core.



**All 16 lb.**..... #18921 ..... \$24.95/ea.



Photo courtesy of GERTMAN2000



**BE COOL RADIATORS**

An OEM radiator just isn't designed to cool a high-horsepower engine, and overheating can take the fun out of driving your classic very quickly. Now, Be Cool has your answer. A high-quality Be Cool radiator will not only lower your temp, but their technology produces radiators that are 40% lighter than copper brass OEM units. Their epoxy free construction provides better heat dissipation while allowing complete repairability. Available in standard finish or polished. Installation note: 1957 6-Cylinder installs will need to modify the hood baffle for clearance of the inlet, all Be Cool radiators use dual 1-inch cores.

RADIATORS



**BE COOL ALUMINUM DOWNFLOW RADIATORS <sup>O/S</sup>**

When mounting in the 6-cylinder position on 1957's, the hood baffle may require modifications.

- 1955-57 Standard, V8 & 6-Cyl. Position**  
..... #13762..... \$599.95/ea.
- 1955-57 Auto, V8 & 6-Cyl. Position**  
..... #13763..... \$699.95/ea.
- 1955-57 Standard, V8 & 6-Cyl. Position, Polished**  
..... #13772..... \$749.95/ea.
- 1955-57 Auto, V8 & 6-Cyl. Position, Polished**  
..... #13773..... \$829.95/ea.

**BE COOL ALUMINUM CROSSFLOW RADIATORS <sup>O/S</sup>**

- 1955-57 Standard** ..... #13764..... \$599.95/ea.
- 1955-57 Auto**..... #13765..... \$699.95/ea.
- 1955-57 Standard, Polished** ..... #13774..... \$749.95/ea.
- 1955-57 Auto, Polished**..... #13775..... \$829.95/ea.
- 1955-57 Standard, LS**..... #17526..... \$699.95/ea.
- 1955-57 Auto, LS** ..... #17527..... \$799.95/ea.
- 1955-57 Standard, Polished, LS...** #17528..... \$799.95/ea.
- 1955-57 Auto, Polished, LS** ..... #17529..... \$849.95/ea.

**BE COOL OE V8 POSITION RADIATORS <sup>O/S</sup>**

What's that you say? You want a vintage radiator design produced with today's technology? By customer demand Be Cool has expanded their industry proven product line with their Be Cool OE series radiators. Be Cool OE series radiators combine a modern aluminum core design with the factory fit, finish and correct-appearing ribbed factory tank design of a stock OE radiator. Your HIGHER than factory-rated horsepower classic Chevy won't overheat with a Be Cool OE series radiator!

- 1955-57 Black, Aluminum, Standard, V8 Position**  
..... #16916..... \$649.95/ea.
- 1955-57 Black, Aluminum, Auto, V8 Position**  
..... #16917..... \$699.95/ea.







**ALUMINUM CROSSFLOW RADIATOR CONVERSION MODULES** O/S

Be Cool's Super Street Series Power Cooling Module assemblies are designed to cool vehicles with up to 700 dyno-rated horsepower. Each kit contains a Be Cool aluminum dual 1-inch core crossflow performance radiator with oval fluted tubes, a dual 11-inch electric puller fan set with vented shroud for highway cruising, a set of fan mounting brackets with hardware, a diamond cut, vented coolant recovery tank, a primary fan wiring harness with a 40 amp relay, a secondary wiring harness to independently control the second fan and to top it all off a Be Cool billet radiator cap. Available in standard finish or polished. Picture is representation only. 1955-57 radiator is slightly different.

1955-57 Standard .....	#13758.....	\$1199.95/ea.
1955-57 Auto.....	#13759.....	\$1299.95/ea.
1955-57 Standard, Polished .....	#13768.....	\$1499.95/ea.
1955-57 Auto, Polished.....	#13769.....	\$1599.95/ea.



*Hope to see you at the Danchuk Tri-Five Nationals!*

PHOTO COURTESY OF GERTMAN2000



**CROSSFLOW POLISHED RADIATOR CONVERSION MODULES** 

Be Cool now offers you the ultimate in crossflow conversion modules. Each system comes fully polished and completely assembled with an aluminum core support, radiator, recovery and reservoir tanks and chrome plated fan shroud with aluminum motor covers. Kits are available with or without air conditioning condenser and with or without integral transmission coolers. Special order item. Drop shipped by vendor. Everything you need to keep your hot rod cool. Be sure to order enough BeCoolant, part #15562 on page 681, to properly protect your investment.

1955 Auto w/ A/C.....	#15521.....	\$3899.95/ea.
1956 Auto w/ A/C.....	#15522.....	\$3899.95/ea.
1957 Auto w/ A/C.....	#15523.....	\$3899.95/ea.
1955 Auto w/o A/C.....	#15524.....	\$3899.95/ea.
1956 Auto w/o A/C.....	#15525.....	\$3899.95/ea.
1957 Auto w/o A/C.....	#15526.....	\$3899.95/ea.
1955 Standard w/ A/C.....	#15527.....	\$3699.95/ea.
1956 Standard w/ A/C.....	#15528.....	\$3699.95/ea.
1957 Standard w/ A/C.....	#15529.....	\$3699.95/ea.
1955 Standard w/o A/C.....	#15530.....	\$3699.95/ea.
1956 Standard w/o A/C.....	#15531.....	\$3699.95/ea.
1957 Standard w/o A/C.....	#15532.....	\$3699.95/ea.

**DESERT COOLER RADIATORS**  

They drop right into your favorite Tri-Five and feature the latest cooling technology. V8 owners can choose from either standard or high-efficiency styles. High-efficiency models are recommended for air conditioning and performance applications. Each unit includes side shims, transmission line fitting, petcock and drain hose making for an easy installation. If the radiator is mounted on the engine side of the core support, you have a V8 core support. If it's on the grille side, then it's a 6-cylinder support. Radiators fit both standard and automatic transmission equipped cars. Don't forget to order a fan shroud, parts #16625-16627C on page 372 for the best in cooling performance. **Made in the USA.**

1955-57 V8 Position, 4-Row .....	#399 .....	\$482.95/ea.
1955-56 High-Efficiency, 3-Row, 6-Cyl. Position .....	#336 .....	\$472.95/ea.
1955-57 High-Efficiency, 4-Row, V8 Position....	#337 .....	\$489.95/ea.
1955-56 High-Efficiency, 4-Row, V8 in 6-Cyl. Position .....	#12072 .....	\$466.95/ea.
1957 Hi-Efficiency, 4 Row, V8 in 6-Cyl. Position.	#12072A	\$466.95/ea.







**U.S. Radiator**



**U.S. RADIATOR ALUMINUM CROSSFLOW RADIATORS** 

Crossflow conversion radiators from US Radiators feature dual 1-inch tubes and have a fully welded construction and come in standard finish or fully polished. Radiators are available in either standard or auto versions and can be ordered with or without fans. Fan controller sold separately.

1955-57 w/ Fans, Auto.....	#17861.....	\$749.95/ea.
1955-57 w/ Fans, Standard.....	#17862.....	\$749.95/ea.
1955-57 w/ Fans, Polished, Auto.....	#17863.....	\$847.95/ea.
1955-57 w/ Fans, Polished, Standard.....	#17864.....	\$847.95/ea.
1955-57 w/o Fans, Auto.....	#17865.....	\$423.95/ea.
1955-57 w/o Fans, Standard.....	#17866.....	\$423.95/ea.
1955-57 w/o Fans, Polished, Auto.....	#17867.....	\$572.95/ea.
1955-57 w/o Fans, Polished, Standard.....	#17868.....	\$572.95/ea.



**U.S. RADIATOR DOWNFLOW ALUMINUM RADIATORS** 

Aluminum Downflow radiators feature fully welded construction (no epoxy) and dual 1" tubes. Radiators are available in either a standard or Tripleflow configuration. Tripleflow radiators achieve the maximum temperature drop by creating walls which force the coolant to pass through the core three times resulting in greater temperature reductions. Aluminum radiators do not have transmission coolers. An auxiliary cooler will be required so be sure to check out our transmission coolers starting on page 517. When mounting #13274 the hood baffle may require modification on '55-'56 application. All triple flow radiator upper inlets are on driver side of top tank. Don't forget to order a fan shroud, parts #16625-16627C on page 372 for the best in cooling performance.

**Made in the USA.**

1955-57 V8.....	#13262.....	\$498.95/ea.
1955-57 V8, Triple Flow.....	#13266.....	\$582.95/ea.
1955-56 V8 in 6-Cylinder Position.....	#13270.....	\$498.95/ea.
1955-56 V8 in 6-Cylinder Position, Triple Flow.....	#13274.....	\$582.95/ea.



**CHAMPION ALUMINUM RADIATORS** O/S

We are proud to offer you Champion Radiators, the latest and greatest in aluminum radiators. All of the radiators that we carry are 100% aluminum from the tank, core, and welds with no epoxy, and come with three rows of 3/4-inch tubes. All Champion radiators are equipped with a transmission cooler.

- 55-56 6-Cyl. Position Std-Auto** ..... #17707 ..... \$299.95/ea.
- 55-56 6-Cyl. Position Std-Auto, Polished** ..... #17708 ..... \$419.95/ea.
- 1955-57 V8 Position Std-Auto** ..... #17709 ..... \$299.95/ea.
- 1955-57 V8 Position Std-Auto, Polished** ..... #17710 ..... \$419.95/ea.

**AMERICAN EAGLE ALUMINUM RADIATORS** O/S

American Eagle Radiators are made with the same high level of quality that the Champion cooling system radiators. They feature the same billet fill necks and no epoxy. All American Eagle radiators feature 2.25" thick core with two 1-inch tubes and a transmission cooler.

- 1955-57 V8 Position Std-Auto** ..... #17713 ..... \$249.95/ea.
- 1955-57 V8 Position Std-Auto, Polished** ..... #17714 ..... \$319.95/ea.



**GRIFFIN ALUMINUM RADIATORS** O/S

These HP series radiators feature a high efficiency core with two 1.25" tubes, and a core thickness of 2.75". Aluminum radiators include side shims, transmission line fittings, petcock and drain hose. Radiators fit standard and automatic equipped cars and are compatible with Danchuk fan shrouds, parts #16625-16627C on page 372.

- 1955-57 V8** ..... #733 ..... \$719.95/ea.
- 1955-56 6-Cyl** ..... #734 ..... \$719.95/ea.
- 1957 6-Cyl** ..... #735 ..... \$699.95/ea.



**HOT RODS BY DEAN COOLING MODULES** O/S

These cooling system modules by Hot Rods by Dean are a complete cooling solution for your Shoebox Chevy. The clean and simple all steel core support is black powder coated and installs in the factory location. This design moves the radiator and fans forward providing the maximum amount of engine compartment space to clear any engine with any serpentine pulley system. The high efficiency single-pass cross-flow radiator has a heavy duty 2.5-inch aluminum core running two 1" tubes. The system comes with a custom mounted overflow tank, 16 lb. polished aluminum radiator cap, dual Maradyne 14-inch high performance electric cooling fans (2135 CFM each), fan relay harness with 185 degree thermostat, dual fan relay, aluminum fan mounting bracket and stainless fasteners. They even include the custom hood latch assembly and hood support with brackets that you need for 1955 applications because these units move the the radiator forward for extra room in the engine compartment. Comes completely assembled with installation instructions. Shown in powdercoated red but delivers in powdercoated black only. Special order item. **Made in the USA.**

<b>1955 Standard, Satin</b> .....	<b>#17925</b> .....	<b>\$2995.95/ea.</b>
<b>1955 Standard, Polished</b> .....	<b>#17926</b> .....	<b>\$3395.95/ea.</b>
<b>1955 Standard, w/ AC, Polished</b> .....	<b>#17927</b> .....	<b>\$3949.95/ea.</b>
<b>1955 Standard, w/ AC &amp; PS, Polished</b> .....	<b>#17928</b> .....	<b>\$4095.95/ea.</b>
<b>1956 Standard, Satin</b> .....	<b>#17929</b> .....	<b>\$2949.95/ea.</b>
<b>1956 Standard, Polished</b> .....	<b>#17930</b> .....	<b>\$3295.95/ea.</b>
<b>1956 Standard, w/ AC, Polished</b> .....	<b>#17931</b> .....	<b>\$3895.95/ea.</b>
<b>1956 Standard, w/ AC &amp; PS, Polished</b> .....	<b>#17932</b> .....	<b>\$4049.95/ea.</b>
<b>1957 Standard, Satin</b> .....	<b>#17933</b> .....	<b>\$2895.95/ea.</b>
<b>1957 Standard, Polished</b> .....	<b>#17934</b> .....	<b>\$3245.95/ea.</b>
<b>1957 Standard, w/ AC, Polished</b> .....	<b>#17935</b> .....	<b>\$3845.95/ea.</b>
<b>1957 Standard, w/ AC &amp; PS, Polished</b> .....	<b>#17936</b> .....	<b>\$3995.95/ea.</b>



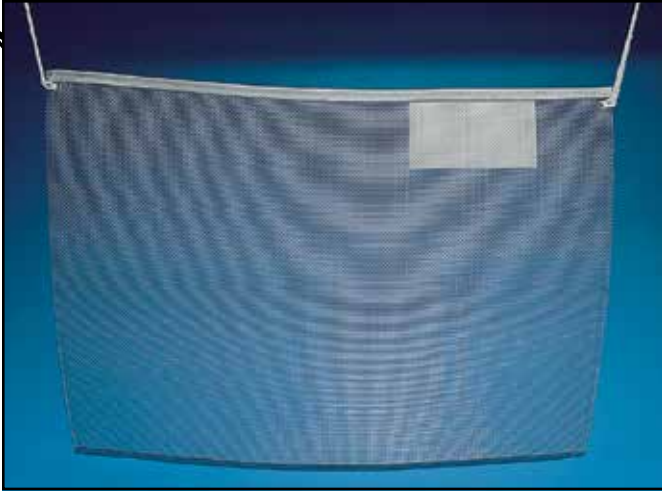

**RADIATOR BUG SCREEN**

If you show your daily driver or drive a show car daily, these bug screens are a must. Easy to install and remove.  
**1955-57 ..... #2871 ..... \$24.95/ea.**

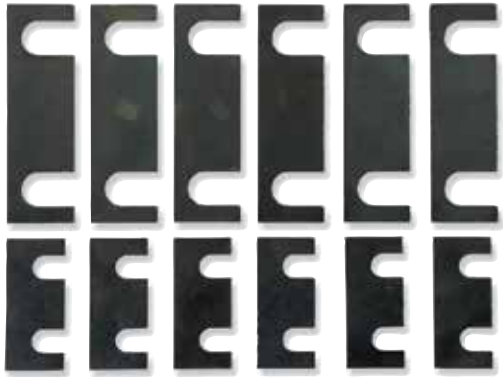

**RADIATOR SUPPORT TO FENDER SHIM KITS**

These install between the ends of the core support upper bar and the inner fenders. They are used to fine tune the alignment of the front fenders. Hardware included.  
**1955-56 ..... #1168 ..... \$10.95/ea.**  
**1957 (Shown) ..... #1169 ..... \$12.95/ea.**

**1957 RADIATOR CORE SUPPORT WIRING GROMMET**

This grommet installs in the radiator filler panel. The connector for the grille bar harness to the main underhood harness fits here.  
**1957 ..... #357 ..... \$5.95/ea.**



**RADIATOR CONVERSION BRACKETS**

Allows you to mount a V8 position radiator into the 6-cylinder position of a V8 core support. **Made in the USA.**  
**1955-57 ..... #11236 ..... \$54.95/pr.**



**RADIATOR SUPPORT TO FRAME SHIMS**

This kit is used with the core support rubber cushions #604 to attach lower section of the radiator core support to the frame bracket.  
**1955-57 ..... #1167 ..... \$13.95/ea.**



**RADIATOR CORE SUPPORT RUBBER CUSHIONS**

These cushions are used with the radiator support to frame shims, #1167, shown above, to attach lower section of the radiator core support to the frame bracket. **Made in the USA.**  
**1955-57 ..... #604 ..... \$13.95/pr.**

**RADIATOR SUPPORT WIRE HARNESS CLIP**

This clip installs on the radiator cross bar and supports the wiring harness. 3-6 clips needed per car.  
**1955-57 ..... #12333 ..... \$0.95/ea.**



SEE PAGES 541-544 FOR RADIATOR CORE SUPPORTS, FILLER PANELS, SUPPORT BARS, AND STRAP ASSEMBLIES.



**CHROME RADIATOR COVERS** 

The first thing they see when lifting the hood is the radiator. Nothing can dress it up better than our chrome radiator covers. Make your engine compartment shine! **Technical Note:** As to not detract from the show quality, our radiator covers are sealed. To access radiator cap, cover needs to be removed. Note: These are for hood up show display only. Must be removed before closing hood or driving. **Made in the USA.**

1955-57 w/ Shroud, Pyramid Peak .....	#2709.....	\$249.95/ea.
1955-57 w/ Shroud, Louvered .....	#2710.....	\$249.95/ea.
1955-57 w/ Shroud, Ribbed .....	#2711.....	\$249.95/ea.
1955-57 Lower, Louvered .....	#2712.....	\$108.95/ea.
1955-57 Lower, Ribbed.....	#2713.....	\$108.95/ea.



**EVANS WATERLESS HIGH PERFORMANCE COOLANT SYSTEM** 

Evans High Performance Waterless Coolant is specifically designed for all modern, classic, and vintage engines. Evans HPC has a boiling point of 375° F while protecting down to -40° and will not vaporize; eliminating boilover and after-boil preventing coolant loss and reducing strain on cooling systems. Since Evans contains no water it effectively eliminates corrosion and minimizes the potential for electrolysis and reduces maintenance costs. When converting an engine from water-based coolant to HPC, great care should be given during the conversion process to ensure that all the old water-based coolant is removed. It is recommended that the system be flushed with Evans Pre-Fluid (part #18460) before installing Evans HPC. When the conversion process is complete, the water content should be no more than 3%. **Made in the USA.**

**EVANS COOLANT ANALOG REFRACTOMETER**

All..... #18595..... \$29.95/ea.

**EVANS WATERLESS HIGH PERFORMANCE COOLANT**

All 1-Gallon..... #18459..... \$46.95/ea.

**EVANS WATERLESS COOLANT PREP FLUID**

All 1-Gallon..... #18460..... \$32.95/ea.



**BILLET SPECIALTIES SMOOTH OVERFLOW TANKS**

The Billet Specialties overflow tanks are the best on the market. Precision machined from 6061 T-6 billet aluminum and polished to the famous Billet Specialties standards they feature two adjustable polished billet mounting straps for precise alignment.

Product Features:

- Knurled O-ring cap for a no-leak seal
- Stainless hardware included
- Aluminum push-on fittings included
- Industry leading mirror finish polish
- Internal return tube

All 8.75" .....	#17096.....	\$149.95/ea.
All 8.75", Black .....	#19307.....	\$142.95/ea.
All 13" .....	#17094.....	\$124.95/ea.
All 15" .....	#17095.....	\$124.95/ea.



**POLISHED STAINLESS STEEL COOLANT OVERFLOW TANK**

This polished stainless steel overflow tank was designed to be kept out of view but it's so beautiful you'll want to show it off. One quart capacity tank with a precision knurled cap and a highly polished finish. Approximately 18-3/4" long, mounting hardware included.

All..... #1274 ..... \$39.95/ea.



**RADIATOR HOSE CLAMP**

1955-57 ..... #12163..... \$1.95/ea.



**RADIATOR AND HEATER HOSE CLAMPS**



A spring style clamp was original equipment on all 1955-1957 Chevy models. **Made in the USA.**

1955-56 .....	#398.....	\$9.95/set
1957.....	#398A.....	\$23.95/set

#15055



#15056

**HOSE ADAPTERS**

In-Line hose adapters provide a threaded fitting for temp senders or fan switches. Features two 1/4-inch threaded ports for sending units.

All 1-1/2", Upper .....	#15055.....	\$49.95/ea.
All 1-3/4", Lower .....	#15056.....	\$54.95/ea.



**RADIATOR ZINC ANODE**

Installs in place of petcock and protects the cooling system from corrosion.

All 1/4" NPT ..... #14845..... \$11.95/ea.





**STEP UP/DOWN RADIATOR HOSES**

With all the different engine and radiator combinations that are being put in classic Chevy's these days sometimes the inlets and outlets don't always match up to the current offering of radiator hoses. These tapered radiator hoses are made of silicone for years of service and are great when a custom application requires custom hoses. Great when using tubing/hose combinations on late model engine and radiator installs.

- All 1-1/4" to 1-3/4" ..... #17773..... \$21.95/ea.
- All 1-1/4" to 1-1/2" ..... #17772..... \$21.95/ea.

**FLEXI-KOOL RADIATOR HOSE KITS**

Flexi-Kool Hose kits are made of ribbed stainless steel which won't freeze or crack. Flexi-Kool hoses ribbed design improves cooling which helps prevent overheating and possible engine damage. Hoses can be formed to any angle or length while reducing installation time and maintenance costs. No longer do you have to search to find a hose that you can make work. Just order a Flexi-Kool hose kit for downflow or crossflow radiator conversions and you know you'll have the right hose all the time. 48" hose kits make two hoses. Matching Flexi-Kool heater hoses are shown on page 368.



- All 24", Chrome, w/ Chrome Caps . #12413..... \$49.95/kit
- All 48", Chrome w/ Chrome Caps .. #12504..... \$69.95/kit

**SILICONE HOSE RADIATOR PLUMBING KIT**

This reinforced silicone radiator plumbing kit includes two 90° elbows, one 45° elbow and one 6-inch straight connector along with one 6-inch aluminum connector and one 45° aluminum connector.



- All..... #17013..... \$89.95/kit



**SHOW QUALITY RADIATOR HOSES**

These radiator hoses are correctly numbered with the GM codes used in 1955, 1956 and 1957. These are the hoses for detail-oriented collectors and anyone seeking to restore the original factory look to their engine compartment. Original style spring clamps are included.

- 1955-57 V8, Upper Hose ..... #044A..... \$22.95/ea.
- 1955-57 V8, Lower Hose ..... #045A..... \$22.95/ea.
- 1955-56 6-Cyl., Upper Hose ..... #046B..... \$21.95/ea.
- 1957 6-Cyl., Upper Hose..... #046A..... \$26.95/ea.
- 1955-57 6-Cyl., Lower Hose ..... #047A..... \$28.95/ea.
- 1956-57 Dual 4BC & F.I., Upper Hose(Not Shown) ..... #2559..... \$43.95/ea.



**RADIATOR HOSES**

Made with the same quality materials as our show quality hoses, but priced for the budget-oriented daily driver. For the 1957 6-Cylinder upper hose, see show quality hoses, above.

- 1955-57 V8, Upper Hose ..... #044..... \$17.95/ea.
- 1955-57 V8, Lower Hose ..... #045..... \$19.95/ea.
- 1955-56 6-Cyl., Upper Hose ..... #046..... \$17.95/ea.
- 1955-57 6-Cyl., Lower Hose ..... #047..... \$19.95/ea.
- 1955-57 V8 in 6-Cyl. Pos., Lower. #10856..... \$17.95/ea.
- 1955-57 Upper, Trim to Fit X-Flow.. #12161 ..... \$23.95/ea.
- 1955-57 Lower, Trim to Fit X-Flow.. #12162..... \$29.95/ea.

**RADIATOR PETCOCK WITH HOSE**

The same brass valve used in 1955, 1956 and 1957, with the original 6" of rubber drain hose included. **Made in the USA.**



- 1955-57 ..... #400..... \$9.95/ea.

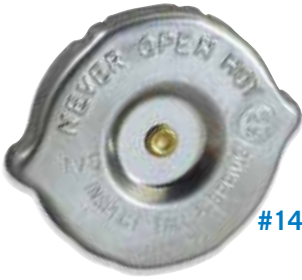

#141



#12160



#17107



#17105



#19377



#19378

**RADIATOR CAPS**

Fits the Desert Cooler® radiator or any other 1955-1957 radiator application. 7-pounds for stock cooling systems or 13-pounds pressure capacity for aluminum radiators with Vintage Air systems.

- 1955-57 7-lb. .... #141..... \$10.95/ea.
- 1955-57 13-lb. .... #12160..... \$7.95/ea.



**RADIATOR CAPS WITH BE COOL LOGO**

A great way to top off your cooling system upgrade. These Be Cool billet radiator caps, besides being great looking, are designed to allow the use of a coolant recovery system where needed.

- All Round Style ..... #13776..... \$49.95/ea.
- All Octagon Style ..... #13777..... \$49.95/ea.

**BILLET SPECIALTIES POLISHED BILLET RADIATOR CAPS**

These Billet Specialties radiator caps are CNC machined from 6061 T-6 billet aluminum. They are a two piece design so you can align it for maximum effect. Comes complete with a quality Stant 16lb radiator cap hidden under the billet shells which match their overflow tanks. NOTE: 7 lb. caps are for use with original heating and cooling systems made before 1966. 16 lb. caps are for use on modern heating and cooling systems made after 1966. **Made in the USA.**

- All Polished Bowtie, 16-lb..... #17105..... \$24.95/ea.
- All Polished Bowtie, 7-lb. .... #17106..... \$24.95/ea.
- All Polished Plain, 16-lb. .... #17107..... \$24.95/ea.
- All Polished Plain, 7-lb. .... #17108..... \$24.95/ea.
- All Black, Notch Grip 16-lb..... #19377..... \$38.95/ea.
- All Black, Plain Grip 16-lb..... #19378..... \$26.95/ea.

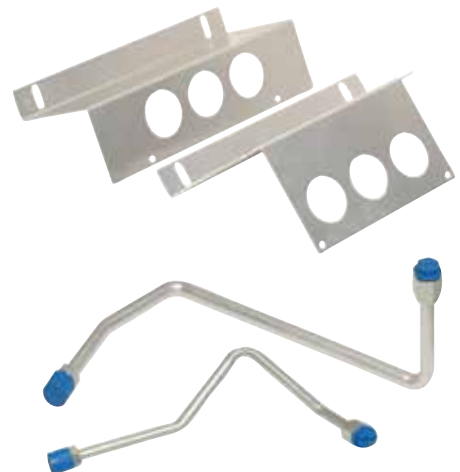

**BE COOL A/C CONDENSER MODULE FOR CROSSFLOW RADIATORS**

Designed to compliment their cross flow radiators this A/C condenser is a necessary part of your cross flow radiator conversion if you have air conditioning in your classic.

- 1955-57 Polished..... #18907..... \$799.95/ea.
- 1955-57 ..... #18908..... \$649.95/ea.



**COMPLETE 134A AIR CONDITIONING UNITS** O/S

Designed specifically for your classic Chevy. System attaches to existing holes in dash and firewall without drilling. These kits now use the fully electronic GEN IV Sure Fit System, which features an electronic conversion for stock heater control levers which eliminates all control cables. Separate heating and cooling coils and SPAL permanent magnet blower motor gives you maximum capacity and performance. To order, call our customer service department with your application to be sure you are ordering the correct kit. These kits come in three box sets, and two of the three boxes need to be shipped oversized which incurs an extra shipping charge. **Note: The 55 with original 265 V8 with oil filter option requires a special order kit.**

1955-56 .....	#2437 .....	\$1469.95/kit
1957 .....	#2439 .....	\$1469.95/kit

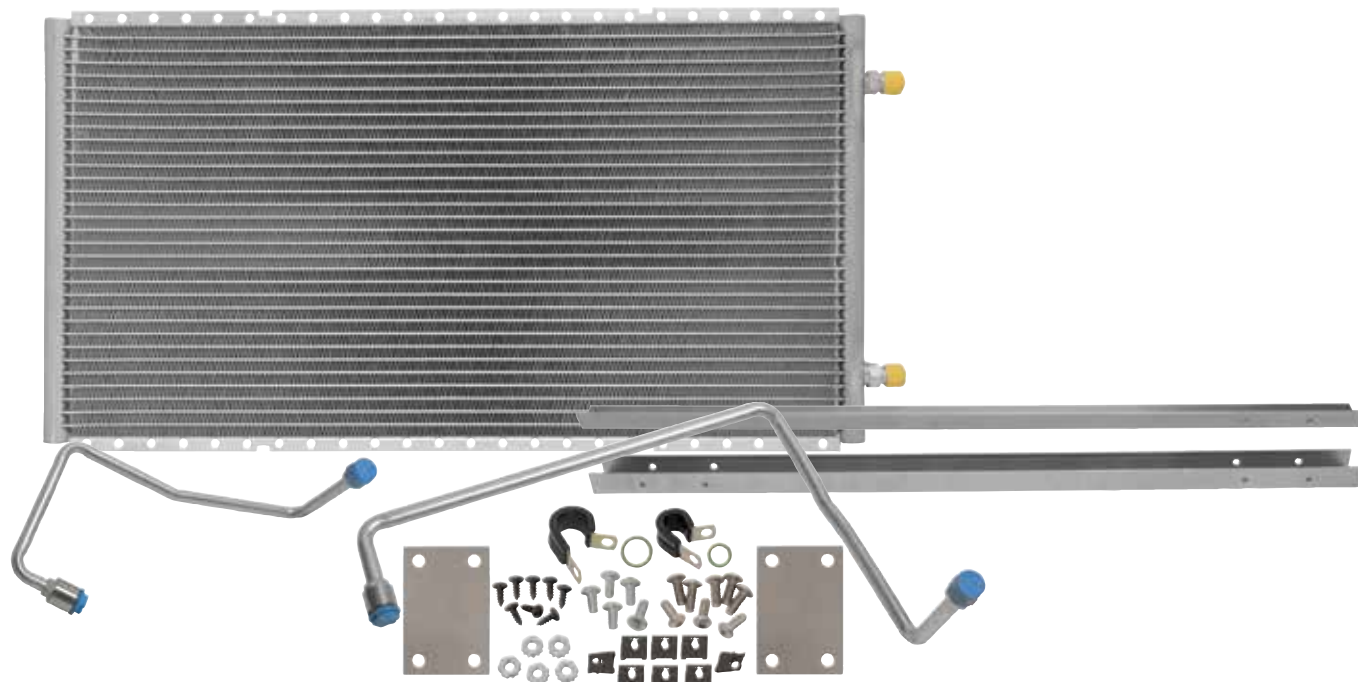

**AIR CONDITIONING CONDENSER**

For use with Crossflow radiators. Some fitting may be required.

1955-57 Unpolished, w/ Lines.....	#12169.....	\$359.95/ea.
-----------------------------------	-------------	--------------



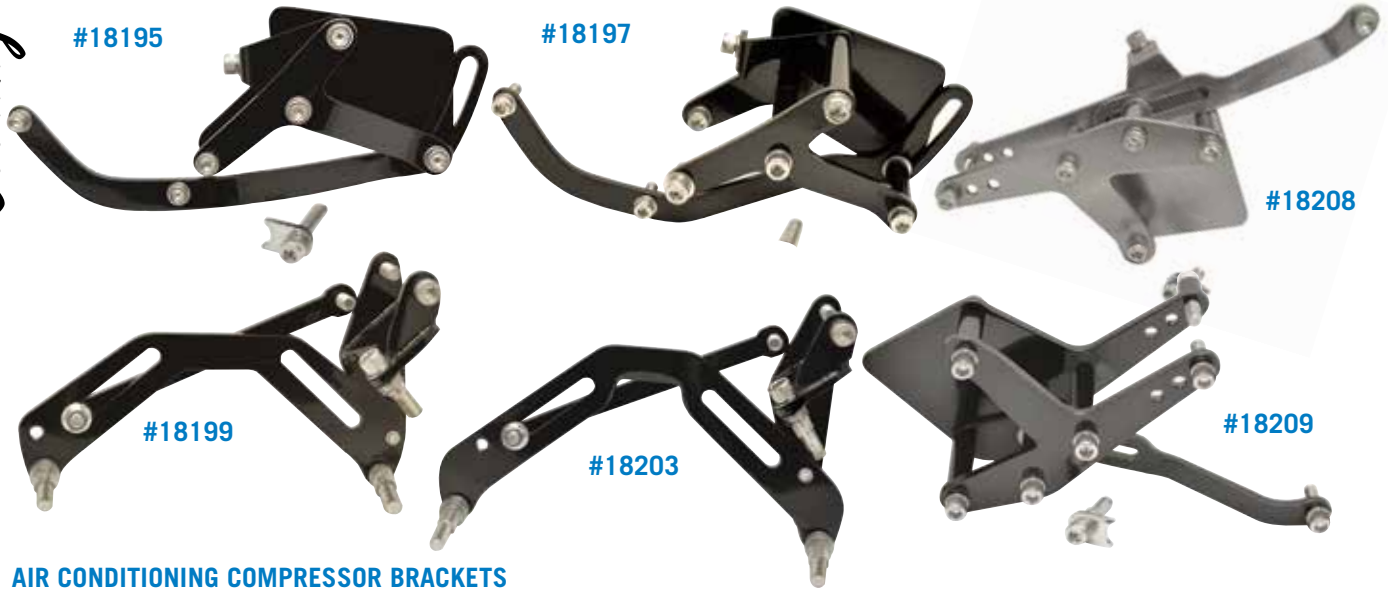

**AIR CONDITIONING COMPRESSOR BRACKETS**

All SB, Short Water Pump, Late Style Heads, Black.....	#18195.....	\$119.95/ea.
All SB, Long Water Pump, Late Style Heads, Passenger, Black .....	#18197.....	\$119.95/ea.
All BB, Short Water Pump, Passenger, Black .....	#18203.....	\$145.95/ea.
All SB, Short Water Pump, Late Heads, Passenger, Plain.....	#18208.....	\$124.95/ea.
All SB, Short Water Pump, Late Heads, Passenger, Black.....	#18209.....	\$139.95/ea.
All SB, Short Water Pump, Late Heads, Passenger, Chrome .....	#18210.....	\$199.95/ea.



#16544



#16542

**AIR CONDITIONING CLUTCH COMPRESSOR COVERS FOR SANDEN 508**

Dress up your Sanden 508 air conditioning Compressor with this aluminum clutch cover, hardware included.

All Chrome, SD508 .....	#16542.....	\$79.95/ea.
All Polished, SD508.....	#16543.....	\$79.95/ea.
All Machined, SD508.....	#16544.....	\$79.95/ea.



**AIR CONDITIONING AND ALTERNATOR BRACKET**

All SB, Short Water Pump, Early Style Heads, Black .....	#18200.....	\$219.95/ea.
--	-------------	--------------



**BILLET SPECIALTIES**

**AIR CONDITIONING CLUTCH COVER FOR SANDEN 508**

All Polished.....	#17047.....	\$47.95/ea.
-------------------	-------------	-------------



**AIR CONDITIONING COMPRESSOR CLUTCH COVER KITS FOR SANDEN SD7 ONLY.**

Matches Front Runner pulleys.

All Plain.....	#12544.....	\$47.95/kit
All Polished.....	#12545.....	\$61.95/kit